



Standard

for Electric Installation and Use



This Page Intentionally Left Blank

Table of Contents

INTRODUCTION	5
FOREWORD	6
EXCEPTION FORM	7
REVISION FORM	8
1. DEFINITIONS	9
2. GENERAL INFORMATION	15
2.1 EFFECTIVE DATE	15
2.2 INTENT	15
2.3 APPLICATION FOR SERVICE	16
2.4 RATE SCHEDULES	19
2.5 SERVICE AND LIMITATIONS	19
2.6 CLOSED LOOP / FLAT TAP / JUMPERED	19
2.7 CONNECTION	19
2.8 CUSTOMER-OWNED METER EQUIPMENT RESTRICTIONS	19
2.9 DIVERSION OF ELECTRICITY	20
2.10 EASEMENTS FOR COMPANY’S FACILITIES	20
2.11 CUSTOMER’S RESPONSIBILITY	20
2.12 CUSTOMER-OWNED FACILITIES	21
2.13 SAFETY	22
2.14 XCEL ENERGY LIMITED TELEPHONE DIRECTORY	25
3. CHARACTER OF SERVICE AVAILABLE	27
3.1 TYPES OF SERVICE	27
3.2 METER SOCKETS FOR TYPES OF SERVICE	28
3.3 DISTRIBUTION (PRIMARY) SERVICE	28
3.4 TRANSMISSION SERVICE.....	28
4. SERVICE FACILITIES	29
4.1 SERVICES.....	29
4.2 OVERHEAD SERVICE.....	30
4.3 UNDERGROUND SERVICE	32
4.4 SERVICE LATERAL SIZES (FOR BALANCED LOAD):.....	35
4.5 CONDUIT SIZING CHART:	35
4.6 TRANSFORMER INSTALLATIONS – NETWORK VAULTS	36
4.7 TRANSFORMER INSTALLATIONS – PAD-MOUNTED.....	37
4.8 POINT OF DELIVERY	37
4.9 CUSTOMER-OWNED SERVICE CONDUCTORS.....	38
4.10 METERING	39
4.11 METER SOCKETS.....	44
4.12 INSTRUMENT TRANSFORMER COMPARTMENTS.....	47
4.13 PRIMARY METER INSTALLATIONS	50
4.14 METER LOCATION AND INSTALLATION.....	51
4.15 METER MOUNTING HEIGHTS	53
4.16 METER CLEARANCES.....	54
4.17 COLD SEQUENCE METERING	55
4.18 HOT SEQUENCE METERING	56

5. TRANSFORMERS	59
5.1 GROUNDING	59
5.2 SPECIAL RULES	59
5.3 FAULT CURRENT.....	60
5.4 ARC FLASH	60
6. UTILIZATION EQUIPMENT	69
6.1 THREE PHASE VOLTAGE UNBALANCE	69
6.2 HARMONICS	69
6.3 POWER FACTOR ADJUSTMENT.....	71
6.4 MOTORS	71
6.5 NON-LINEAR LOADS	73
6.6 WATER PIPE THAWING.....	74
6.7 SPECIAL APPARATUS.....	74
6.8 LOAD BALANCE	74
7. SPECIAL TYPES OF SERVICE.....	75
7.1 NON-STANDARD CONSTRUCTION	75
7.2 DATA PULSES.....	75
8. DISTRIBUTED ENERGY RESOURCES.....	77
8.1 INTERCONNECTION REQUIREMENTS	77
8.2 LABELING/PLACARD REQUIRMENTS	77
8.3 METERING REQUIREMENTS	78
8.4 TELEMETRY REQUIREMENTS	79

Drawings

<i>Section SC: Self-Contained Metering Drawings.....</i>	<i>1.1-1.35</i>
<i>Section TR: Transformer Rated Metering Drawings.....</i>	<i>2.1-2.8</i>
<i>Section PM: Primary Metering Drawings.....</i>	<i>3.1-3.8</i>
<i>Section TM: Temporary Metering Drawings.....</i>	<i>4.1-4.6</i>
<i>Section IR: Interruptible Rate Drawings.....</i>	<i>5.1-5.6</i>
<i>Section EV: Electric Vehicles.....</i>	<i>5.7-5.12</i>
<i>Section CC: Connection Cabinet Drawings.....</i>	<i>6.0-6.6</i>
<i>Section CC: Transformer Pad Drawings.....</i>	<i>6.7-6.106</i>
<i>Section CR: Clearance Requirements Drawings.....</i>	<i>7.1-7.13</i>

INTRODUCTION

Xcel Energy is dedicated to providing safe, economical, and reliable service to its customers. It is the policy of the Company to serve all its customers in an orderly manner and assist in securing a more beneficial use of electricity. The “Xcel Energy Standard for Electric Installation and Use” contains the requirements and uniform standards necessary to achieve this policy. Uniform enforcement of these standards throughout the Company will expedite service connections and treat each of our customers equally and fairly. Therefore, our employees are instructed and obligated to require adherence to these standards and procedures.

The “Xcel Energy Standard for Electric Installation and Use” is a valuable timesaving publication that will help to determine the necessary requirements for customers’ wiring intended to be connected to the Company’s distribution system. This publication will help you work more efficiently and aid in getting a utility connection established with minimum inconvenience. It also provides for the safety and reliability of our customers and safe working conditions for our personnel.

The Company’s complete Rules and Regulations are contained in its tariffs as filed with the various state regulatory agencies. Service furnished by the Company is subject to the Company’s “Xcel Energy Standard for Electric Installation and Use”, the National Electrical Safety Code, and the Rules and Regulations of these Regulatory Commissions.

Xcel Energy, Inc.

*Briston Jones, Manager*System Performance & Standards*

FOREWORD

This publication has been prepared to assist you in planning your electrical installation. The uniform standards contained in this publication are necessary to enable the Company to serve all its customers in an orderly manner and expedite service connections.

New, rewired, altered, or repaired wiring installations intended for connection to the Company's distribution system shall comply with the rules of the Company, the *National Electrical Code*[®], and any other codes or regulations in effect in the area served. The Company does not assume the function of inspecting customers' wiring for adequacy, safety, or compliance with the electrical codes. Such responsibility remains with the customer and inspectors.

Questions concerning large and/or complicated electrical projects should be directed to the Company's Builders Call Line ***in advance of construction and/or purchase of equipment*** @ 800.628.2121 or Meter Technical Support @ 800.422.0782. This will reduce the risk of project delays or expensive changes during construction.

A Company Representative will discuss requests for exceptions to these standards with the customer. Only requests for exceptions based on extenuating circumstances will be evaluated. The exception request shall be submitted in writing ***in advance of construction and/or purchase of equipment***. Exception requests are evaluated on a case-by-case basis and will be responded to in writing. Exceptions will not be granted verbally. The written response will indicate whether the request has been granted or denied. Exceptions shall be submitted to the following:

- To request an exception to our policy in MN, ND, or SD, please send completed form to:
 - Service Policy Consultant
825 Rice Street
St. Paul, MN 55117
- To request an exception to our policy in WI or MI, please send completed form to:
 - Service Policy Consultant
P.O. Box 8
Eau Claire, WI 54702
- To request an exception to our policy in CO, TX, or NM, please send completed form to:
 - Service Policy Analyst
5460 W. 60th Street
Arvada, CO 80003

Customers may email exception requests to EMStandardsExceptionRequest@xcelenergy.com.

Due to constant progress in the development of materials and processes, the Company reserves the right to revise this publication from time to time. Users of this book who notice better processes of providing services are encouraged to submit suggestions and/ or revisions for changes to these standards. Revisions are necessary for continued application of work practices.

If the proposed suggestions and/or revisions to the standards offer equal or better safety and reliability than the current policy, the policy will be reviewed for possible revision.

The Company's complete Rules and Regulations are contained in its Tariffs as filed with the Commission in your state.

This publication is Available at: <http://www.xcelenergy.com/>

APPLICATION

Exception Form

XCEL ENERGY STANDARD FOR ELECTRIC INSTALLATION AND USE

This form is to be used when requesting an exception to the "Xcel Energy Standard For Electric Installation and Use". Make sure to include all details and/or any additional documentation, such as installation information, one-lines or plot maps. Please print legibly, type or complete on line. Exceptions will not be granted if reliability or safety is compromised.

A granted exception request will only be valid for 1 calendar year from the date of the Company's response letter. Exceptions must be filed before construction.

Project Information

Address of job _____ City _____ State _____ ZIP _____

I seek an exception to the following section(s):

I request the following exception:

This practice will maintain/improve safety and reliability by:

Submitter Information

Submitter name _____ Company name _____ Date _____

Company address _____ City _____ State _____ ZIP _____

Phone (_____) _____ Fax (_____) _____

Mail to the OpCo address below or Email to EMStandardsExceptionRequest@xcelenergy.com

**For: Wisconsin, Michigan
Service Policy
PO Box 8
Eau Claire, WI 54702
Fax: 715-852-5456**

**Minnesota, South Dakota and North Dakota
Service Policy
825 Rice Street
St. Paul, MN 55117
Fax: 612-573-1708**

**Colorado, Texas and New Mexico
Service Policy
5460 W. 60th Ave.
Aurora, CO 80003
Fax: 303-425-3888**

Revision Form

XCEL ENERGY STANDARD FOR ELECTRIC INSTALLATION AND USE

This form is to be used when requesting a revision to the "Xcel Energy Standard For Electric Installation and Use". Make sure to include all details and/or any additional documentation, such as Section, page number and illustrations. Please print legibly, type or complete on line. Revisions will not be granted if reliability or safety is compromised.

I seek a revision to the following section(s):

I request the following revision:

This practice will maintain/improve safety and reliability by:

Submitter Information

Submitter name _____ Company name _____ Date _____
Company address _____ City _____ State _____ ZIP _____
Phone (_____) _____ Fax (_____) _____

Mail to the address below or Email to EMStandardsExceptionRequest@xcelenergy.com

For: Wisconsin, Michigan
Service Policy
PO Box 8
Eau Claire, WI 54702
Fax: 715-852-5456

Minnesota, South Dakota and North Dakota
Service Policy
825 Rice Street
St. Paul, MN 55117
Fax: 612-573-1708

Colorado, Texas and New Mexico
Service Policy
5460 W. 60th Ave.
Aurada, CO 80003
Fax: 303-425-3888

SECTION 1

1. DEFINITIONS

Note: The Following definitions are furnished for the appropriate interpretation of this document and are not necessarily universally accepted definitions.

1.1 **ACCESS POINT**

The point defined by the intersection of the customer's property line and the Company-owned conductors crossing it, which serves that customer. When a customer is to be served from a distribution line in an easement on the customer's property, the access point is the pole for overhead (OH), the switch cabinet bay for primary underground (UG), or the transformer, splice box or pedestal for secondary underground (UG) from which the Company-owned conductors will be fed.

1.2 **AGENT**

One who is authorized to act for another under a contract or relation of agency, for the Company or the customer.

1.3 **ALTERED**

Replacing major components or any integral part of a meter socket, current transformer cabinet, riser, mast, line or load side conductor, or relocating electric service equipment, (including storm damage).

1.4 **AMI – ADVANCED METERING INFRASTRUCTURE**

A metering infrastructure that supports advanced features including two-way communications for such functions as meter reading, the ability to support tariffs for time-of-use, system critical peak pricing, demand response, Distributed Energy Resources (DER), and support for and disseminating information/updates to advanced meters.

1.5 **AMR – AUTOMATED METER READING**

An automated method of reading electric registers (indexes).

1.6 **APPLICANT**

The property owner, lessee, sub-lessee, their agent and/or contractor applying for electric service from the Company.

1.7 **AUTHORIZED CLOSED LOOP**

Authorized use of electric service that is temporarily not being metered. See definition for (CLOSED LOOP).

1.8 **BUS DUCT**

A preassembled unitized device containing secondary electrical bus.

1.9 **CAPTIVE FASTENER**

A fastener that is loosely held in place and cannot separate from fastened object. Usually manufactured from metal with various designs.

1.10 **CLASSIFICATION OF METERING**

Commercial and Industrial (See definition for COMMERCIAL AND INDUSTRIAL METERING). Residential (See definition for RESIDENTIAL METERING).

1.11 **CLOSED LOOP**

Temporary unmetered electric service. (See definitions for FLAT TAP and JUMPERED).

1.12 COLD SEQUENCE METERING

The utilization of a disconnect device between the electric meter and the supply source. Refer to Section 4.17, COLD SEQUENCE METERING.

1.13 COMMERCIAL AND INDUSTRIAL METERING

Metering of any service used for the operation of a business, whether or not for profit, shall be considered as a commercial or industrial enterprise. Includes metering of all services other than residential.

1.14 COMMISSION

Public Utilities Commission of Colorado, Michigan Public Service Commission, Minnesota Public Utilities Commission, New Mexico Public Regulation Commission, North Dakota Public Service Commission, South Dakota Public Utilities Commission, Public Utility Commission of Texas and Wisconsin Public Service Commission.

1.15 COMPANY

The operating Companies of Xcel Energy®

1.16 COMPANY PROPERTY

All lines, wires, apparatus, instruments, meters, load management equipment, transformers, and materials supplied by the Company at its expense or under its standard policies.

1.17 COMPANY REPRESENTATIVE

The Company employee authorized to perform specific tasks.

1.18 CONDUIT

Standard tubular material used for mechanical protection of electrical systems which may be exposed, buried beneath the surface of the ground, or encased in a building structure as required. (See definition for DUCT).

NOTE: For the purpose of this publication, the terms Conduit and Duct are used interchangeably.

1.19 CONSTRUCTION ALLOWANCE

The portion of the construction cost performed by the Company at its expense.

1.20 CONSTRUCTION TRAILER

A structure built on a permanent chassis designed to be transportable which is intended for installation on a site without permanent foundation.

1.21 CONTRACTOR

Any person, company or corporation acting under contractual agreements for either the Company or for the customer.

1.22 CURRENT TRANSFORMER (CT)

An instrument transformer designed for the measurement or control of current.

1.23 CUSTOMER

The applicant or user of electric service in whose name the service with the Company is listed.

1.24 DATA PULSES

Output pulses (KYZ) generated by the electric meter for use by the Customer.

1.25 DEAD-END EQUIPMENT

Various devices used to terminate service conductors.

1.26 DISTRIBUTED ENERGY RESOURCE (DER)

Sources of electric power that are not directly connected to a bulk power transmissions system. DER includes both generators and energy storage technologies.

1.27 DISTRIBUTED GENERATION (DG)

Electric generation facilities connected to an area electric power system through a point of common coupling; a subset of distributed energy resources.

1.28 DISTRIBUTION

System of wires, poles, meters, and other utility equipment that facilitates the delivery of low and medium voltage (120V – 35kV) electricity to end use customers.

1.29 DIVERSION OF ELECTRICITY

Unauthorized connection to the Company's electric facilities where electric service is being used and not metered (e.g. when the electric meter has been bypassed without a closed loop authorization from the Company).

1.30 DUCT

Standard tubular material used for mechanical protection of electrical systems which may be exposed, buried beneath the surface of the ground, or encased in a building structure as required. (See definition for CONDUIT).

NOTE: For the purpose of this publication, the terms Conduit and Duct are used interchangeably.

1.31 EMT

Electric Metallic Tubing (*National Electrical Code*[®]).

1.32 EXCESS FACILITIES

In those instances where the Company provides distribution or metering facilities at the customer's request, in excess of the facilities necessary to supply service to the customer, the customer shall be required to contract to pay the Company for such facilities and to pay the Company annually an amount to cover the cost of insurance, replacement (or cost of removal), licenses, fees, taxes, operation, maintenance, and appropriate allocable administrative and general expenses of such excess distribution facilities.

1.33 FLAT TAP

Temporary unmetered electric service. (See definitions for CLOSED LOOP and JUMPERED).

1.34 GAIN

Cutting a flat spot into a pole or attaching a metal device to a pole which has a flat surface on one side.

1.35 GRC

Galvanized Rigid Conduit (*National Electrical Code*[®]).

1.36 HIGH LEG, WILD LEG, POWER LEG

The phase having the higher phase voltage to ground on a 4-wire delta-connected service, where the midpoint of one phase winding is grounded.

1.37 HOT SEQUENCE METERING

The electric meter is connected directly to the service conductors without the use of a fault-current limiting disconnect or meter safety-switch device between the electric meter and the supply source.

1.38 HOUSE POWER SERVICE

An electric service for any and all common loads (i.e. lighting, irrigation, elevators, laundry facilities, etc.) utilized by residential or commercial multi-tenant buildings. Only one house power service per building is permitted unless the requirements for multiple services in Section 4.1 are met.

1.39 ICE AND SNOW SHIELD, METER

A protective device used to prevent falling ice or snow from damaging the electric meter.

1.40 IMC

Intermediate Metallic Conduit (*National Electrical Code*[®]).

1.41 INSPECTOR

The electrical inspector of the Public Authority.

1.42 INSTRUMENT TRANSFORMER

A transformer that reproduces in its secondary circuit, the voltage or current proportional to its primary circuit.

1.43 ISOLATED TRANSFORMER BANK

A transformer bank which provides electrical service to a single customer.

1.44 JOINT USE AGREEMENT

A contractual agreement made between the Company and a third party allowing the use of Company property or facilities.

1.45 JUMPERED

Temporary unmetered electric service. (See definitions for CLOSED LOOP and FLAT TAP).

1.46 MANUFACTURED HOME

A structure which is transportable and intended for installation on a permanent foundation meeting the definition of a Manufactured Home as defined in the 2017 *National Electrical Code*[®] Article 550.2, or as may be amended.

1.47 MEANS OF ATTACHMENT

Fittings used to attach service drop conductors.

1.48 METER/METERING EQUIPMENT

The equipment necessary to measure the customer's electric energy use and demand included meter socket, instrument transformers, protective device and meter.

1.49 MOBILE HOME

A structure built on a permanent chassis designed to be transportable and intended for installation on a site without permanent foundation.

1.50 MULTIPLE METER CENTER

A pre-assembled multiple metering unit or fabricated meter center using meter sockets where two or more customers are metered at a common location.

1.51 NEC[®] - NATIONAL ELECTRICAL CODE^{®1}

A publication of the Nation Fire Protection Association, Inc.

1.52 NESC[®] - NATIONAL ELECTRICAL SAFETY CODE^{®2}

A publication of the Institute of Electrical and Electronics Engineers, Inc. as adopted by ANSI.

1.53 NETWORK SERVICE

Electrical service provided by the Company through a system of electric feeders that are cross connected and operated as to permit instantaneous redundant power supply to any point within the network service area for the purpose of automatic load transfer to an alternate source of electric supply, in the event of loss of delivery of electric power and energy from the principal source of electric supply. Electric network service and service

¹ *National Electrical Code*[®] and *NEC*[®] are registered trademarks of the National Fire Protection Association, Inc., Quincy MA 02269

² *National Electrical Safety Code*[®] and *NESC*[®] are registered trademarks and service marks of the Institute of Electrical and Electronics Engineers, Inc., New York, NY 10017

areas are determined solely by the Company and are limited to an applicable customer within specific areas determined by the Company.

1.54 NOMINAL VOLTAGE

Designation of the value of the normal effective difference in potential between any two appropriate conductors of the circuit.

1.55 NON-STANDARD DESIGN

Construction not conforming to the Company's standard method of design because of the customer's request. The customer may be charged for the additional cost incurred by the Company.

1.56 NRTL

Nationally Recognized Testing Laboratory

1.57 POINT OF ATTACHMENT

The point at which the service drop conductors are attached to a building or other structure.

1.58 POINT OF DELIVERY

The point where the Company's electric facilities are first connected to the electric facilities of the customer.

1.59 PRIMARY METERING

Metering of service voltages above 480 V nominal.

1.60 PUBLIC AUTHORITY

The municipal, county, or state authorities having inspectors and jurisdiction to inspect electrical installations.

1.61 PVC

Polyvinyl Chloride (*National Electrical Code*[®]).

1.62 RACEWAY

Any channel for holding bus bars, cables, or wires, which is designed for this purpose.

1.63 RESIDENTIAL METERING

Metering of services used for the exclusive use of the individual customer for domestic purposes.

1.64 READILY ACCESSIBLE

An area that can be readily and safely accessed through a doorway, ramp, or stairway by a person on foot who neither exerts extraordinary physical effort nor employs special tools or devices to gain entry is considered readily accessible.

1.65 REPAIRED

Service equipment in need of any repair such as damaged meter socket, rise, mast (including storm damage).

1.66 REWIRED

Upgrading of any existing service equipment including secondary conductors within meter sockets, CT enclosures, cold sequence disconnects, and Primary Metering Installations.

1.67 RULES AND REGULATIONS

The rules, regulation and condition of service as filed with the Commission.

1.68 SECONDARY CONDUCTORS

The part of the Company's distribution system, which connects the secondaries of the Company's distribution transformers to the service drop or service lateral.

1.69 SECONDARY CONNECTION CABINET

Cabinet required when the number and/or size of conductors exceeds the Company's limit for terminating in a specified pad-mounted transformer.

1.70 SERVICE

The furnishing of electric energy for the exclusive use of the individual customer.

1.71 SERVICE DROP

The overhead service conductors from the last distribution pole or other aerial distribution support to and including the splices connecting to the service-entrance conductors at the building or other structure.

1.72 SERVICE-ENTRANCE CONDUCTORS, OVERHEAD SYSTEM

The service conductors between the terminals of the customer's service equipment and the point of connection to the service drop conductors.

1.73 SERVICE-ENTRANCE CONDUCTORS, UNDERGROUND SYSTEM

The service conductors between the terminals of the customer's service equipment and the point of connection to the service lateral.

1.74 SERVICE EQUIPMENT

Necessary equipment, usually consisting of a circuit breaker or fusible disconnect switch and their accessories, located near the point of entrance of the supply conductors to a building and intended to constitute the main control and means of cutoff for the supply to that building.

1.75 SERVICE LATERAL

The underground service conductors between the Company secondary distribution system and/or transformer terminals and the connection to the service-entrance conductors in a terminal box or meter socket located outside the building wall. Where the meter is located in the building and no terminal box exists outside the building, the point of connection shall be considered the point of entrance of the service conductors into the building.

1.76 SERVICE MAST

The service mast is the conduit containing the service-entrance conductors where the point of attachment and the connection between the service drop and the service-entrance conductors is located **above** the roofline. The conduit extends to a point, and the weather head is located, above the roof eave. The conduit passes through the eave of the building or extends past the roofline without passing through the eave. The means of attachment is attached to the service mast.

1.77 SERVICE RISER

The service riser is the conduit containing the service-entrance conductors where the point of attachment and the connection between the service drop and the service-entrance conductors is located on a pole or **below** the roofline of the building being served. The conduit extends to a point, and the weather head is located, below the roof eave. The means of attachment is secured to the pole or building and is not attached to the service riser.

1.78 SERVICE TERRITORY

Colorado (CO), Michigan (MI), Minnesota (MN), New Mexico (NM), North Dakota (ND), South Dakota (SD), Texas (TX) and Wisconsin (WI).

1.79 VOLTAGE TRANSFORMER (VT)

An instrument transformer intended for use in the measurement of control of a circuit and designed to have its primary winding connected in parallel with the circuit.

1.80 VOLTAGE UNBALANCE

Maximum voltage deviation from average voltage.

SECTION 2

2. GENERAL INFORMATION

The Company has filed its Rules and Regulations with the Commission as a part of the Tariffs of the Company, which set forth the terms and conditions under which electric service is supplied and govern all classes of service in all the territory served by the Company. The Rules and Regulations are subject to termination, change, or modification, in whole or in part, at any time as provided by the rules of said Commission. Copies of the Rules and Regulations are available for any customer's inspection at the offices of the Company.

Service furnished by the Company is also subject to: The Xcel Energy Standard for Electric Installation and Use, the *National Electrical Code*[®] and the *National Electrical Safety Code*[®].

The Company assumes no responsibility whatsoever for the manufacture's, supplier's, electrician's, or engineering consultant's compliance with all applicable *NEC*[®] and *NESC*[®] codes as well as all local and state codes.

Any waiver at any time of the Company's rights or privileges under the Rules and Regulations will not be deemed a waiver as to any breach or other matter subsequently occurring.

The following are brief statements of those operating rules and practices, which affect the majority of connections made to the Company's lines. Where information not included herein is needed, a Company Representative will provide assistance.

2.1 EFFECTIVE DATE

This edition of the Xcel Energy Standard for Electric Installation and Use may be used at any time on or after the publication date. Additionally, this edition shall become effective no later than November 15, 2018 in all service areas.

2.2 INTENT

The word "shall" indicates provisions that are mandatory.

The word "should" indicates provisions that are normally and generally practical for the specified conditions.

The word "may" indicates possibility.

The words "recommend" and "recommended" indicate provisions considered desirable, but not intended to be mandatory.

Exceptions to a rule have the same force and effect required or allowed by the rule to which the exception applies. All requests for exceptions shall be submitted in writing and will be responded to in writing. Verbal exceptions will not be granted.

Requirements of the *National Electrical Code*[®], *National Electric Safety Code*[®], or the Public Authority which are more stringent than the requirements of this document will take precedence.

2.3 APPLICATION FOR SERVICE

The customer may contact the Company's Builders Call Line to secure information relative to any application for new electric service connections or changes in existing service. Service telephone numbers for the Company can be found at the end of this Section.

Before an electric service connection can be made to the customer's (applicant's) wiring system, it is necessary that:

1. The customer has made application for service.
2. The application has met all requirements of The Xcel Energy Standard for Electric Installation and Use and the Rates, Rules, Regulations and Extension Policy in effect and on file with the Commission at the time construction starts.
3. The Company has completed its construction.
4. The Public Authority has notified the Company of approval of the installation by providing an inspection release.

Where no Public Authority has jurisdiction, the Company, for the customer's protection, may require written confirmation from the wiring electrician that the customer's installation conforms to the *National Electrical Code*[®].

In WI and MI, the Proof of Compliance form in this Section shall be completed and presented to the Company before electric service is energized.

The Company does not assume responsibility for the design, operation or condition of the customer's installation.

The Company may make service available from either overhead or underground facilities. In cases where there are aesthetic considerations or where complicated overhead physical situations exist, the Company may recommend the installation of underground facilities.

The Company will not install facilities to serve a customer until the customer agrees to take the service under the applicable Rate Schedule and all applicable charges for construction and service, as required by the Company's Extension Policy, are paid to the Company. Additional costs incurred for digging in frost conditions when insufficient time was provided to estimate, plan, schedule, and construct the necessary facilities prior to the onset of frost conditions will be paid by the customer as a nonrefundable charge.

The Company shall not under any circumstances be required to make an extension, which would be unprofitable and thereby cause undue hardship upon other customer of the Company.

It is extremely important that the Company be consulted in advance of the finalization of the customer's plans regarding the Company's electric service requirements.



Electric Inspection Certificate

Builders Call Line phone: 800.628.2121

Email addresses: Minnesota/North Dakota/South Dakota: BCLMN@xcelenergy.com

Colorado: BCL-CO@xcelenergy.com

Texas/New Mexico: BCL-TXNM@xcelenergy.com

Date _____ Owner/builder _____

Service address _____ Apt., suite, unit
(List all that need energized at time of inspection) _____

City _____ State _____ ZIP _____

Phone number _____ Cell phone _____

Electric contractor _____

Phone number _____ Cell phone _____

General contractor _____

Phone number _____ Cell phone _____

Check appropriate boxes:

- | | | |
|--------------------------------------|---|--|
| <input type="checkbox"/> Residential | <input type="checkbox"/> Temporary service | <input type="checkbox"/> Overhead service |
| <input type="checkbox"/> Farm | <input type="checkbox"/> Permanent services | <input type="checkbox"/> Underground service |
| <input type="checkbox"/> Commercial | <input type="checkbox"/> Rewire/upgrade | |

Number of phases _____ **Voltage** _____ **Entrance size (amps)** _____

Remarks _____

At the above-described premise, the installation was done in compliance with the provision of all applicable codes, safety standards and Xcel Energy service rules. Xcel Energy is not responsible for customer owned equipment past the point of delivery and will not inspect customers' wiring for adequacy, safety, or compliance with applicable electrical codes on the customer's side; such responsibility remains with the customer and authorities having jurisdiction. If the customer is signing, the customer acknowledges and agrees to a general release, and further expressly waives and assumes the risk of any and all claims for damages which exist as a result whether known or unknown to exist, whether through ignorance, oversight, error, negligence or otherwise, and which, if known, would materially affect customers decision to sign this document. The installation is now ready for connection.

Print name of electrical contractor _____	
License number _____	Contractor phone _____
Signature of electrical contractor _____	Date _____
Only use the lines below if state laws permit homeowners to perform electrical work on their dwelling and there is no authority having jurisdiction to inspect the wiring.	
Print name of owner/builder _____	Owner/builder phone _____
Signature of owner/builder _____	Date _____

For customers in Michigan and Wisconsin, please call or email the builders call line for the Michigan/Wisconsin specific inspection certificate. 800.628.2121 or BCL-WI@xcelenergy.com; Minnesota/North Dakota/South Dakota: BCLMN@xcelenergy.com; Colorado: BCL-CO@xcelenergy.com; Texas/New Mexico: BCL-TXNM@xcelenergy.com

***Before electricity can be furnished this form must be completely filled out, signed and returned to the appropriate Xcel Energy Builders Call Line email address. Please make sure the document is legible.



Electric Inspection Certificate

Builders Call Line
Phone: 800.628.2121
Fax: 888.742.5623
Email: BCLWI@xcelenergy.com
Mail: Xcel Energy, BCL - Sky Park, P.O. Box 8 Eau Claire, WI 54702

Date _____ Owner/builder _____ Phone _____

 Site address _____ Apt., suite, unit
 (List all that need energized at time of inspection) _____

City _____ State _____ ZIP _____

Electric contractor _____ Electric contractor phone _____

General contractor _____ General contractor phone _____

Check appropriate boxes:

- | | | |
|--------------------------------------|---|--|
| <input type="checkbox"/> Residential | <input type="checkbox"/> Temporary service | <input type="checkbox"/> Overhead service |
| <input type="checkbox"/> Farm | <input type="checkbox"/> Permanent services | <input type="checkbox"/> Underground service |
| <input type="checkbox"/> Commercial | <input type="checkbox"/> Rewire/upgrade | <input type="checkbox"/> Solar installation |

Number of phases _____ **Voltage** _____ **Entrance size (amps)** _____

Remarks _____

At the above-described premise, the installation was done in compliance with the provision of all applicable codes, safety standards and Xcel Energy service rules. Xcel Energy is not responsible for customer owned equipment past the point of delivery and will not inspect customers' wiring for adequacy, safety, or compliance with applicable electrical codes on the customer's side; such responsibility remains with the customer and authorities having jurisdiction. If the customer is signing, the customer acknowledges and agrees to a general release, and further expressly waives and assumes the risk of any and all claims for damages which exist as a result whether known or unknown to exist, whether through ignorance, oversight, error, negligence or otherwise, and which, if known, would materially affect customers decision to sign this document. The installation is now ready for connection.

Homeowner must own and primarily reside in home to sign off on inspection for installing, modifying, and/or repairing electrical service and equipment. Applicable to Disconnect/Reconnect Work Only; Meters cannot be removed and/or off prior to work performed.

 Print name of homeowner/
 electric contractor _____ Signature of homeowner/
 electric contractor _____

License number _____ Phone _____ Date _____

**Print name of master electrician (if applicable) _____ License number _____

For solar, UDC and commercial inspections only

***Uniform Dwelling Code (UDC) Inspection is a requirement for new construction one- and two-family dwellings. Solar inspection required January 2018.

**Commercial inspections required (as applicable). Signature required verifying the installation was done in compliance with all applicable codes.

 Print name of
 electric inspector _____ Signature of
 electric inspector _____

Certified inspection number: _____ Date of approval _____

Before electricity can be furnished this form must be completely filled out, signed and returned to Xcel Energy. Please make sure this form is legible.

**Per WI State Statute 101.862(1), effective April 1, 2014, Statute 101.862 (2) No person may engage in the business of installing, repairing, or maintaining electrical wiring unless the person is licensed as an electrical contractor by the department. (3) No person who is not a master electrician may install, repair, or maintain electrical wiring unless a master electrician is at all times responsible for the person's work. The electrical license number must accompany the electrician's signature to be valid.

**The State of Wisconsin has adopted NEC 2017 addition. All commercial services are required to be inspected no later than January 1, 2020. Xcel Energy will keep you informed of any updates to the requirements prior to this date.

***In Michigan, all storm related repairs and/or modifications must be completed by a licensed electrician. An inspection shall be required to re-energize the service.

2.4 RATE SCHEDULES

Electric service is supplied to customers under the Company's established rates, rules, regulations, and marketing programs as approved by the applicable Commission having jurisdiction in each state. Rate brochures for residential, commercial, and industrial customers, covering rate schedules and their application are available from the Company upon request. Company Representatives will assist the customer in understanding the Company's rates and in applying them to the customer's load conditions.

2.5 SERVICE AND LIMITATIONS

The Company shall render service from the nearest suitable power line of sufficient capacity to furnish adequate service at the service voltage available. Service shall not be used by the customer for purposes other than those specified in the applicable Rate Schedule.

2.6 CLOSED LOOP / FLAT TAP / JUMPERED

Closed loops may or may not be allowed in the service territory or locale where service is needed. Refer to Section 4.10.2, Existing Services.

2.7 CONNECTION

Connection to or disconnection from the Company's distribution system shall be made by the Company. Under no circumstances will the customer be permitted to climb the Company's poles, access the Company's underground facilities, or make connections to the Company's lines, except as specified in Section 2.13.4 SAFETY, Unlock, Open, and/or De-energize any Electric Power Equipment Procedures in this Section.

The Company shall be notified when it is necessary to cut the meter seal due to situations where the electric service must be disconnected during an emergency or where it necessary to access the meter socket by a qualified person. No persons, other than employees or agents of the Company, may relocate meters or other equipment owned by the Company.

2.8 CUSTOMER-OWNED METER EQUIPMENT RESTRICTIONS

Under no circumstances shall customers' equipment:

1. Be connected to, or in any way be served from, the secondary terminals of the voltage and/or current metering transformers.
2. Be installed within any metering enclosures including, but not limited to, metering transformer cabinets, transformer compartments, secondary connection cabinets, meter sockets or cold sequence disconnect.
3. Be connected to an unmetered bus or conductor.
4. Utilize plug in devices such as surge suppression, generator transfer switch, or any equipment designed to fit between the meter and the socket.
5. Attach foreign objects such as but not limited to CATV, phone loops, grounding clamps and load monitoring equipment, etc. to meter/metering equipment, service riser or service mast.
6. Include a customer-owned transformer installed ahead of any company metering, except as permitted by local tariffs.

2.9 DIVERSION OF ELECTRICITY

Under no circumstances shall devices or attachments be connected to the Company's facilities in such a manner as to permit the use of unmetered energy except in emergencies where specifically authorized by the Company. Refer to Section 4.10.2, Existing Services.

2.10 EASEMENTS FOR COMPANY'S FACILITIES

The customer shall provide, at the request of and at no cost to the Company, necessary easements and suitable land area or building space owned and controlled by the customer for installation, construction, reconstruction, maintenance, operation, control and use of the Company's overhead and/or underground facilities used or useful to render service to the customer. If a secondary connection cabinet is required, the transformer and secondary connection cabinet shall be located on the property being served. The instrument transformers and metering shall always be located on the property being served.

2.10.1 Zero Lot Line Builds

The customer shall contact the Company if they are considering a zero lot line build. While many jurisdictions permit a zero lot line build, the customer is required to leave room for the necessary electric facilities. Transformers, secondary connection cabinets, CTs and metering must be located outside the building footprint. If a secondary connection cabinet is required the transformer and secondary connection cabinet shall be located on the property being served, CTs and metering shall always be located on the property being served and room must be left for installation, maintenance, operation and use of the Company's overhead or underground facilities.

2.11 CUSTOMER'S RESPONSIBILITY

The customer shall give authorized employees of the Company access at all reasonable times to the premises of the customer in order to obtain information concerning connected load, to measure or test service, to read meters, or for other purposes incidental to the supplying of electric service. Failure to comply may result in disconnection of services.

It is the responsibility of the customer to adequately protect the Company's equipment located on the customer's property against damage. The customer shall be responsible for any damages or loss resulting from improper protection or neglect.

Pad-mounted transformers, switchgear, and metering equipment shall be installed with adequate clearances for normal maintenance work as specified in Section 5 and the Illustrations Section.

Underground distribution facilities will not be installed until the property is to final grade (± 6 inches), the property pins are installed, and the structure is staked or foundation is installed as applicable. Grade at pad-mounted equipment shall be to exact final grade. Whenever it is deemed necessary by the Company, the customer shall provide Company-approved conduit. This will be required in locations that are not readily accessible by the Company such as under driveways, roads, parking lots, sidewalks, patios, etc.

Customers shall connect their equipment so that the load at the point of delivery will be balanced as nearly as practicable. Where three-phase service (except 3-phase, 4-wire delta) is supplied, the customer will attempt to connect equipment so that the load in any one phase at the point of delivery will not exceed the load in any other phase by more than ten (10) percent. Refer to Section 6.1, THREE-PHASE VOLTAGE UNBALANCE.

2.12 CUSTOMER-OWNED FACILITIES

Distribution facilities, either overhead or underground, beyond the Company's point of delivery are to be installed, maintained, and operated by the customer under all the following conditions:

1. All energy is to be metered at one location. The Company will not permit or install any Company owned subtractive (sub) metering.
2. Each installation is subject to the provisions of the Company's Rules and Regulations, the applicable Rate Schedule, and the approval of the Company.
3. Under rates providing for delivery at secondary voltages, the Company will install and maintain only a single transformer installation for the customer, except as specified in Section 4.1, SERVICES.
4. The Company will not install or permit the installation of any of the following customer-owned equipment on Company poles: meter sockets, metering equipment, distribution wires, posters, banners, placards, radio or television aerials, or other objects or devices.

Exception: Wires for municipal fire alarm systems, police signal systems, customer's underground service extensions to the overhead system, customer's dead-end equipment, or metering equipment, (including meter sockets, conduit, etc.) covered by Joint Use Agreement or Pole License Agreement.

Note: Meter sockets and other metering equipment shall not be installed on Company poles.

5. The customer's distribution system shall be in conformance with the *Nation Electrical Code*[®], the wiring regulations of the Public Authority, and the Company's Rules and Regulations.
6. The distribution facilities of the customer beyond the point of delivery shall be connected to the Company's distribution system at one central point through protective devices, approved by the Company, installed and maintained at the expense of the customer.
7. Customers shall maintain their distribution system in a safe operating condition so that it does not constitute a hazard to themselves or to other customers or persons. The Company assumes no responsibility for inspection of the customer's lines and facilities and shall not be liable for injury to persons or damage to property when occurring on or caused by the customer's lines or equipment.
8. All wiring and other electrical facilities beyond the point of delivery shall be installed, owned, operated, and maintained by the customer. Such facilities shall be located on and traverse only land owned or controlled by the customer. A customer who is taking services under a commercial or industrial rate may cross dedicated public streets, alleys, or other public way upon approval of the Company and the public body having jurisdiction, so long as such facilities are necessary for the purpose of serving customer's contiguous buildings or locations which are separated only by such streets, alleys and ways, and provided that such contiguous buildings or locations are used for an integral purpose. The customer's distribution facilities shall be installed in compliance with the *National Electrical Code*[®], the *National Electrical Safety Code*[®], the wiring regulations of the public body having jurisdiction, and the Company's Rules and Regulations.
9. If a secondary connection cabinet is required the transformer and secondary connection cabinet shall be located on the property being served. CTs and metering shall always be located on the property being served.
10. Refer to Section 4 for additional requirements for customer-owned facilities.

2.13 SAFETY

Refer to federal regulations and individual state laws concerning safety requirements relating to high voltage power lines of public utilities, which produce, transmit, or deliver electricity. The following explanations should not be regarded as a substitute for reading the laws, but are meant to highlight some of the major points.

2.13.1 Overhead Safety

Caution: Overhead wires and conductors are not insulated for protection from contact. Please exercise care when working near overhead facilities.

Each year a number of accidents involving contact with high voltage overhead lines occur, often resulting in serious injury or death. In an effort to prevent these types of accidents, laws have been enacted to provide safer working conditions in areas around high voltage overhead lines.

These laws apply, with few exceptions, to any person or business entity contracting to do work or perform any activity, which may bring an individual or equipment within 10 feet of high voltage overhead lines in excess of 600 volts. If work is to be performed within 10 feet of high voltage lines, the public utility shall first be contacted to arrange for safety provisions. The Company is required to provide a cost estimate for making those provisions. If there is a dispute over the amount to be charged, the Company will proceed in a timely manner to provide the safety measures and the dispute will be settled at a later date. If work is begun after an agreement has been reached and before the safety provisions have been made, the person or entity performing the work shall be liable for damages resulting from contact with high voltage overhead lines. Violations of these laws may result in a fine and/or possible liability for damages resulting from contact with high voltage overhead lines.

2.13.2 Underground Safety

Caution: Stakes, flags, or painted lines mark the locations of underground utilities. Please dig very carefully within 18" on each side of the markings.

Anyone planning to dig in or near a public road, street, alley, right-of-way, or utility easement shall notify the Company of your intent, no less than 48 hours (2 working days) before you dig. Call the telephone number listed below for your locale.

National, Call Before You Dig Line 811

✓ Colorado, Utility Notification Center	800-922-1987
✓ Michigan, Miss Dig	800-482-7171
✓ Minnesota, Gopher State One Call (Outside Metro Area)	800-252-1166
✓ Minnesota Gopher State One Call (Metro Area)	651-454-0002
✓ New Mexico One Call	800-321-2537
✓ North Dakota, North Dakota One Call	800-795-0555
✓ South Dakota, South Dakota One Call	800-781-7474
✓ Texas, DIG TESS	800-344-8377
✓ Wisconsin, Diggers Hotline	800-242-8511

Utility Facilities may be buried along the rear, side, and front property lines in any of the residential areas. Residential service lines may cross homeowner's front and back yards. Many facilities are also located within the street, alley, or highway rights-of-way.

Color Codes: (Verify color codes used within your locale)

Red	Electric Power Lines, Cables, Conduit and Lighting Cables
Yellow	Gas, Oil, Steam, Petroleum, or Gaseous Materials
Orange	Communication, Alarm or Signal Lines, Cables or Conduit, including Cable TV
Blue	Water, Irrigation and Slurry Lines
Green	Storm Drain Lines/Sewer
Pink	Survey Markings
White	Proposed Excavation

2.13.3 Change of Grade

The grade in any public right-of-way or easement shall not be changed without first contacting the Company to determine if electric facilities are contained within the right-of-way or easement. Permission may be granted to change the grade by the Company Area Engineering Department if the grade change will not affect the minimum clearance requirements. Company construction may be necessary if the grade change will necessitate moving equipment or facilities. The Company Area Engineering Department can provide an estimate for the cost to relocate facilities when necessary to provide adequate clearance.

2.13.4 Unlock, Open and/or De-energize any Electric Power Equipment Procedures

The Company established procedures to assure maximum safety to protect all individuals prior to unlocking, opening and/or de-energizing electric power equipment where access by unauthorized personnel is required. The following procedures apply to, but are not limited to, energized Company facilities such as vaults, transformers, manholes, switchgear and secondary pedestals:

1. The customer shall request and receive access authorization prior to the Company Representative unlocking, opening, and/or de-energizing any electric power equipment.
2. Normally, a transformer will not be permanently energized until the secondary service is complete. In cases where it is necessary to leave the transformer energized, such as installing additional secondary conductors, the Company Representative will unlock the transformer and stand by while work is performed and relock the transformer when the work is completed.
3. When a de-energized transformer is opened by the Company Representative for a contractor to pull cable the contractor shall relock the transformer and notify the Company Representative before leaving the worksite.
4. Charges for work may apply when Company personnel are required to open and close transformers or other electric equipment and stand by while work is performed around energized equipment. The Company Representative will determine the amount to be charged.

2.13.5 Energization of Electric Service

The Company will not energize an electric service or set meters on new, rewired, altered, or repaired wiring installations unless all of the following conditions have been met:

1. The premises served have been properly identified by the customer. Refer to Sections 4.14.3, 4.14.4, and 4.14.5 for Meter Socket Identification
2. Meter trace verification has been performed by the Company's local Electric Meter Department.
3. An inspection release from the local Public Authority has been received by the Company.

Note 1: In locations where there is no local Public Authority, the customer is exempt from inspection, and/or the service has been shut off or disconnected for more than 365 days (1 year), the licensed electrician or wireman shall submit a signed and dated Xcel Energy Electrical Inspection Certificate to the Company's Builders Call Line attesting that the electrical installation has been completed and installed according to the current National Electrical Code[®], the Xcel Energy Standard for Electric Installation and Use, and any other applicable codes that apply before electric service is energized.

Note 2: Transformer-rated services may have meters set prior to the inspection release and energization.

4. Services that have been shut off or disconnected for more than 365 days (1 year), must meet current installation requirements in order for service to be reconnected. The Company will evaluate customers' metering equipment for compliance with the requirements. The Company is not responsible for customer owned equipment past the point of delivery and will not inspect customers' wiring for adequacy, safety, or compliance with applicable electrical codes; such responsibility remains with the customer and authorities having jurisdiction. In addition, an inspection release from the local public authority shall be provided to the Company. Where there is no local public authority, or in instances where the public authority cannot provide an inspection release, a licensed electrician must fill out the Xcel Energy Electric Inspection Certificate, located in Section 2, or provide a release on their Company letterhead to the Builders Call Line.
5. The Company Representative has verified that the service entrance shows no continuity, load, or voltage feedback on the load-side terminals of the electric meter or instrument transformer metering installation.
6. The Company Representative has verified that the customers' equipment has a mechanical means to disconnect and isolate equipment from the load-side terminals of the self-contained electric meter socket or instrument transformers (CTs and VTs). This requirement includes, but is not limited to, any load produced by transformers (dry-type or oil-filled) that are used for a separately derived system.
7. The Company Representative has verified that the electric service meets all of the requirements in Section 4.

Note: The meter socket shall meet all requirements listed under METER SOCKETS in Section 4.11.

2.14 XCEL ENERGY LIMITED TELEPHONE DIRECTORY

Service Telephone Numbers:

- | | |
|---|--------------|
| ✓ Builders Call Line for New or Existing Accounts | 800-628-2121 |
| ✓ Denver Metropolitan Area Closed Loop Desk | 303-425-3951 |
| ✓ Emergency/Lights Out | 800-895-1999 |
| ✓ Gas Emergency/Gas Odor | 800-895-2999 |
| ✓ Residential Customer Service | 800-895-4999 |
| ✓ TDD/TYY (Hearing Impaired Service) | 800-895-4949 |
| ✓ Business Solution Center | 800-481-4700 |
| ✓ Home Solution Center | 800-824-1688 |
| ✓ Electric Meter Technical Assistance | 800-422-0782 |

Email Address

EMStandardsExceptionRequest@xcelenergy.com

This Page Intentionally Left Blank

SECTION 3

3. CHARACTER OF SERVICE AVAILABLE

Contact the Company for information regarding availability of any desired type of service in a given locale. Delays and unnecessary expense may be avoided by contacting the Company in advance of construction.

3.1 TYPES OF SERVICE

The service voltages listed below may not be available in each of the Company's service territories. The Company will assist in determining whether the service voltage requested is offered under the Company's Tariffs within the service territory. These service voltages are all derived from grounded transformer banks. Depending upon the service voltage, either the neutral or one phase conductor is grounded at the supply transformer and will be run from the transformer installation to the meter socket.

Customers requiring an ungrounded service for operation of a ground detection system, or for other operations permitted by the *National Electric Safety Code*[®], shall submit an exception request detailing the special circumstances necessitating the request.

Customers accepting three-phase service from an open-delta transformer bank shall sign a liability waiver form indicating the customer's acceptance of potential damage to customer's equipment due to voltage unbalance.

3.1.1 Available Service Voltages by State

Voltage	State							
	CO	MI	MN	ND	NM	SD	TX	WI
120 V, 1Ø, 2W	X ¹	X ¹	X ²	X ²	X	X ²	X	X ¹
277 V, 1Ø, 2W		X ¹						X ¹
480 V, 1Ø, 2W			X ²	X ²	X	X ²	X	
120/240 V, 1Ø, 3W	X	X	X	X	X	X	X	X
120/208 V, 1Ø, 3W	X ⁵		X ⁵		X ⁵		X ⁵	
240/480 V, 1Ø, 3W			X ³	X ³		X ³		
240 V, 3Ø, 3W					X		X	
480 V, 3Ø, 3W					X ¹		X ¹	
120/208 V, 3Ø, 4W	X	X	X	X	X	X	X	X
120/240 V, 3Ø, 4W	X		X ⁴	X ⁴	X	X ⁴	X	
277/480 V, 3Ø, 4W	X	X	X	X	X	X	X	X

¹ By Exception Only

² Street Lighting Only

³ Highway Lighting Only

⁴ With Prior Approval (OVERHEAD ONLY)

⁵ Served from three-phase transformers only, refer to Section 6.8 LOAD BALANCE

Contact the Company for information regarding the availability of Primary Distribution and Transmission voltages.

3.2 METER SOCKETS FOR TYPES OF SERVICE

1. Self-Contained – Supplied by the customer (Refer to Section 4.11, METER SOCKETS)
 - a. 1Ø 2W, 1Ø 3W, and 3Ø 3W Delta – 5 Terminal meter sockets
 - b. 3Ø 4W Wye and 3Ø 4W Delta – 7 terminal meter sockets
2. Transformer Rated (CTs) – Supplied by the Company
 - a. 1Ø 2W, 1Ø 3W – 8 terminal meter sockets (6 terminal meter sockets MI, MN, ND, SD, and WI only)
 - b. 3Ø 3W Delta – 8 terminal meter sockets
 - c. 3Ø 4W Wye and 3Ø 4W Delta – 13 terminal meter sockets

3.3 DISTRIBUTION (PRIMARY) SERVICE

Electric energy will be supplied at the voltage of Company's distribution line of adequate capacity for the load to be served. The Company will advise the applicant as to the primary voltage available and will specify the location of the primary metering installation.

Primary service is not available in Company's Network Service Area.

Secondary service voltage is not permitted for customers already supplied with primary service voltage, and primary service voltage is not permitted for customers already supplied with secondary service voltage.

3.4 TRANSMISSION SERVICE

Electric energy will be supplied at the voltage of the Company's existing transmission lines at locations specifically approved by the Company. Such service will be supplied only in locations accessible to the Company's transmission lines.

SECTION 4

4. SERVICE FACILITIES

The Company will provide service from either overhead or underground distribution facilities, depending upon availability, initial construction costs, and jurisdictional authorities. Where there is a choice of overhead versus underground service, the Company will normally offer the form requiring the least initial construction cost, in which case the customer may elect to choose the alternate, but charges will apply.

The customer shall confer with the Company Representative before purchasing equipment, beginning construction of a proposed installation or altering existing service installations. The Company Representative will determine if the type of service and voltage desired by the customer is available, determine if additions to the Company's facilities will be required, and contact the Company's local Electric Meter Department to secure a definite meter location and point of delivery. The Company Representative will arrange for all necessary alterations and determine any applicable fees.

When the Company is required by order of a Public Authority to alter its distribution system, necessitating a change in the location of the point of delivery, the Company will designate a new point of delivery. The customer, at his expense, shall relocate the service entrance conductors and metering equipment to the new point of delivery. The relocated service shall comply with the installation standards contained within this manual.

4.1 SERVICES

A building or other structure will be supplied by only one service, in accordance with 2017 *National Electrical Code*[®] Article 230.2, or as may be amended.

The policy pertaining to the Company providing additional services for a building or group of buildings will vary depending upon the service territory. In most cases, additional charges for initial construction and perpetual maintenance costs will apply for the additional service(s). Contact the Company Area Engineering Department for specific information.

Only one service (point of delivery) will be provided to a building or other structure, except as specified below:

1. Special Conditions – Additional services may be provided by the Company for:
 - a. Emergency lighting.
 - b. Fire Pumps
 - c. Legally required standby systems.
 - d. Optional standby systems
 - e. Parallel power production systems.
2. Special Occupancies – Additional service may be provided by the Company for:
 - a. Multiple-occupancy buildings where the Company determines that there is no available space for service equipment accessible to all occupants.
 - b. A single building or other structure where the Company determines that such building or structure is sufficiently large to make two or more services necessary.

3. Capacity Requirements - Additional services may be provided where the Company determines that it cannot adequately provide service at a single point of delivery.
4. Different Characteristics - Additional services may be provided by the Company for different voltages or phases, or for loads with different rate schedules.

4.2 OVERHEAD SERVICE

4.2.1 Overhead System – Low Voltage (0-480 Volts)

General Requirements:

1. Service Connection – Service drop conductors will be installed and connected to service entrance conductors in accordance with the Company’s Rules and Regulations.
2. Point of Attachment – The Company will specify the location of the service entrance conductors most suitable for connection to the Company’s lines.
 - a. The customer shall furnish and install the physical means of attachment.
 - b. The point of attachment shall be located within 24” of the weatherhead and at a point nearest the Company’s facilities to be used to provide services. Refer to the Illustrations Section, **Drawing SC-10**.
 - c. The point of attachment shall be located such that adequate clearance can be obtained for the service drop from trees, awnings, patio covers, foreign wires, adjacent buildings, swimming pools, etc. Service drops shall not pass over adjacent private property, except where permitted by easement. Specified heights and clearance may be maintained by use of an approved service mast through the roof.
 - d. Vertical Clearance from Ground – Refer to 2017 *National Electric Safety Code*[®] Article 232 and Table 232-1, or as may be amended. Service drop conductors, where not in excess of 600 volts nominal, shall have the following minimum clearances from final grade:
 - i. Over spaces and ways subject to pedestrians:
 - 12’ 6” – Open Wire
 - 12’ 0” – Triplex, Quadraplex, etc.

Exception 1 : Where the height of a building or other installation does not permit the 12’ 6” clearance, 10’ 6” clearance for insulated service drops limited to 300 volts to ground and 10’ clearance for insulated service drops limited to 150 volts to ground are permitted.
 - ii. Over driveways:
 - 16’ 6” – Open Wire
 - 16’ 0” – Triplex, Quadraplex, etc.

Exception 2: Where the height of a residential building does not permit the 16’ clearance, 12’ 6” clearance for insulated service drops limited to 300 volts to ground and 12’ clearance for insulation service drops limited to 150 volts to ground are permitted.
 - iii. Over other land traversed by vehicles:
 - 16’ 6” – Open Wire
 - 16’ 0” – Triplex, Quadraplex, etc.

- iv. Drip loops shall meet the same clearances as specified above for service drops.

Exception 3: Where the height of a residential building does not permit the specified clearance, 10' 6" clearance for insulated drip loops limited to 300 volts to ground and 10' clearance for insulated drip loops limited to 150 volts to ground are permitted.

- e. The point of attachment shall not be higher than twenty-four (24) feet above final grade.
3. Service Mast/Riser Supports – Only the Company's power service drop conductors shall be attached to a service mast. Phone loops, cable TV conductors, grounding clamps, etc. shall not be attached to the service mast, riser, or meter housing. Refer to 2017 *National Electrical Code*[®] Article 230.28 or as may be amended.
- a. Service Mast – The service mast is the conduit containing the service-entrance conductors where the point of attachment and the connection between the service drop and the service entrance conductors is located **above** the roofline. The conduit passes through the eave of the building or extends past the roofline without passing through the eave. The means of attachment is attached to the service mast. Service masts shall be 2" minimum GRC. The point of attachment shall not exceed 48" above the roofline. If the weatherhead exceeds 48" above the roofline, then the mast shall be braced or guyed by the customer. Conduit couplings shall not be installed above the roofline. Refer to the Illustrations Section, **Drawing SC-10** showing typical installation method.
 - b. Service Riser - The service riser is the conduit containing the service-entrance conductors where the point of attachment and the connection between the service drop and the service-entrance conductors is located on a pole or **below** the roofline of the building being served. The conduit extends to a point, and the weatherhead is located, below the roof eave. The means of attachment is secured to the pole or building and is not attached to the service riser. Service Riser size, per *National Electrical Code*[®]. Refer to the Illustrations Section, **Drawing SC-10** showing typical installation method.
4. Ice and Snow Shields – A meter ice and/or snow shield may be required on all new or rewired services in locations with heavy snowfall or ice loading and in locations above 6000 feet in elevation. For installations where one or more of these conditions are present, all electric meters shall be located on the gable or non-drip side of a building or other structure, and there shall be no adjacent rooflines which will drip directly on or towards a neighboring meter installation. Any installation deemed unsafe by the Company may be disconnected. **Prior approval by the Local Electric Meter Department is required to install service mast and/or meter on a drip side if it is not practical to install on gable end.** Check with the Company's local Electric Meter Department to determine requirements for your locale. Refer to the Illustrations Section, **Drawing SC-20 and SC-20A** showing typical installation methods.

Note: Due to excessive snowfall, ice and snow shields will not be permitted in the following Colorado counties: Eagle, Lake, Park and Summit. Meters shall be installed on the gable or non-drip side of a building or in an approved remote location from the building or structure in these counties.

5. Service Drops – The allowable length of service drop conductors shall be governed by the slope of the ground, intervening trees and obstructions, and the size of the conductor required.

Conductor (Duplex , Triplex or Quadraplex)	Maximum Service Span* (Utility pole to House knob)
#6	110'
#4	110'
#2	90'
1/0	80'
4/0	70'
500	50'

*Service tension is limited to 800 lbs under ½” ice 32° F Loading conditions

6. Secondary Poles - If the service span length is larger than allowed in the table above, secondary will need to be extended to a new company provided pole on the customer’s property. From the new pole the service can be extended to the house. A suitable easement may be required before such installation is made.
7. Service Entrance Conductors - Service entrance conductors shall have a current carrying capacity at least as great as that required by the *National Electrical Code*[®] and the Public Authority having jurisdiction. The Company strongly recommends that some provision be made for future load increase. A sufficient length of wire, but in no case less than twenty-four (24) inches on residential or thirty-six (36) inches on commercial services, shall extend from the service weather head for connection to the Company's service drop. Line and load conductors are not permitted in the same raceway or conduit. No conductors, other than service entrance conductors, shall be installed in the service entrance conduit. All line-side (non-metered) conductors shall be in a continuous length of conduit from the point of delivery to the meter socket or the cold sequence metering disconnect. Junction boxes, conduit fittings (e.g. LB's), or other devices are not allowed without specific approval from the Company's local Electric Meter Department. Wireways and bused gutters with provisions for a company padlock may be used on installations of two or more meters. For Company-owned, underground service lateral, wireways or bused gutters will be the point of delivery, and any connectors and terminations shall be supplied and made by the customer.

4.2.2 Overhead System – Primary Voltage (Above 480 Volts)

Because of safety precautions, which must be exercised in the utilization of energy at voltages in excess of 480 volts, the Company shall be consulted in regard to service entrance, transformer location, and meter installation details for this class of service before construction is started.

Overhead service of 2400 volts or greater will not be attached directly to a building except where such building is used in a substation or transformer room. Refer to the Illustrations Section, **Drawing PM-10** for typical installation of primary voltage service.

4.3 UNDERGROUND SERVICE

4.3.1 Underground System – Low Voltage (0-480 Volts)

General Requirements:

1. Service Connection - Underground service laterals from underground distribution systems or overhead distribution systems shall be installed in accordance with the Company's Rules and Regulations.
2. Point of Entry – The Company shall specify the location of the underground service lateral and metering equipment location most suitable for connection with the Company's facilities. The

company will not run an underground service lateral through a wall below grade or above the first floor level.

3. Ice and Snow Shields - A meter ice and/or snow shield may be required on all new or rewired services in locations with heavy snowfall or ice loading and in locations above 6000 feet in elevation. For installations where one or more of these conditions are present, all electric meters shall be located on the gable or non-drip side of a building or other structure, and there shall be no adjacent rooflines, which will drip directly on or towards a neighboring meter installation. Any installation deemed unsafe by the Company may be disconnected. **Prior approval by the Local Electric Meter Department is required to install service mast and/or meter on a drip side if it is not practical to install on gable end.** Check with the Company's local Electric Meter Department to determine requirements for your locale. Refer to the Illustrations Section, **Drawing SC-20 and SC-20A** showing typical installation methods.

Note: Due to excessive snowfall, ice and snow shields will not be permitted in the following Colorado counties: Eagle, Lake, Park and Summit. Meters shall be installed on the gable or non-drip side of a building or in an approved remote location from the building or structure in these counties.

4. Underground Service Laterals – Laterals shall not be installed until property is to final grade (± 6 inches), property pins are in place, and the cable route is free of obstructions.
 - a. Company owned service laterals shall not be installed at a depth of less than twenty-four (24) inches.

Note: WI and MI only, the customer shall provide a minimum of 5 inch conduit or equivalent space per set of conductors. The standard service length is 25 feet or less. Conduit is to have a maximum of two 90 degree sweeps. Consult with the Company if a longer service is necessary. The customer may be responsible for additional charges for non-standard service lengths. For conduit lengths over 50 feet, steel sweeps are required.
 - b. Customer-owned commercial and industrial service laterals shall be installed in accordance to the 2017 *National Electrical Code*[®] or as may be amended.
 - c. Electric and plastic gas services within the same trench shall be separated by twelve (12) radial inches. Steel gas services shall not be installed in the same trench with an electric service. The trenches for electric service and steel gas service shall be a minimum of twelve (12) inches apart.
 - d. Service conductors under hardscape shall be in conduit where the conduit extends two (2) feet beyond the hardscape edge.
 - e. Conduit ells for service wire shall have a minimum radius of thirty-six (36) inches.
 - f. In accordance with the NESC Section 351C2, building or other structures are not permitted to be located directly above or within twelve (12) inches of underground conductors. In the event a building or structure is built over underground conductors, the customer may be responsible for costs associated with relocating the service conductors.
 - g. Residential service facilities shall be located on and traverse only land owned or controlled by the customer.
 - h. In TX/NM only, all Overhead to Underground Service Laterals that do not utilize a secondary pedestal will be Company owned. For service laterals extending directly from a pad mounted transformer, residential services will be Company owned while commercial

services will be Customer owned unless Customer owned metering cabinet is on the same pad as the transformer. For all installations utilizing a secondary connection cabinet or a secondary pedestal, the Service Lateral will be Customer owned.

5. Ground Movement – A slip sleeve or expansion joint shall be furnished and installed by the customer on all new and rewired underground residential meter installations and recommended for all commercial installations.
 - a. A slip sleeve shall be an eighteen (18) inch length of 2½” Schedule 40 or 3” Schedule 80 PVC conduit. The slip sleeve shall be buried to a depth of nine (9) inches so that nine (9) inches is exposed above final grade.
 - b. An expansion joint shall be a minimum eighteen (18) inch length Schedule 80 PVC installed at the bottom of the meter housing.

Note: Effective March 31, 2014 the customer will be responsible for providing the slip sleeve or expansion joint for underground service risers.

Refer to 2017 *National Electrical Code*[®] Article 300.5(J)(FPN), or as may be amended and to the Illustrations Section, **Drawing SC-30, SC-40, SC-50, SC-90, and TR-10** for typical slip sleeve installations.

6. Service Entrance Conductors – Service entrance conductors shall have a current carrying capacity at least as great as required by the *National Electrical Code*[®] and the Public Authority having jurisdiction. The Company strongly recommends that some provision be made for future load increase. Line and load conductors are not permitted in the same raceway or conduit. No conductors, other than service conductors, shall be installed in the service lateral conduit. Each service run shall be contained within its own conduit (A, B, C phases and neutral) on commercial services. Junction boxes, conduit bodies (e.g. LB's), or other devices are not allowed without specific approval from the Company's Local Meter Department. Drawings showing typical methods for installing service-entrance conductors are contained in the Illustrations Section. Wireways and bused gutters with provisions for a Company padlock may be used on installations of two or more meters. For Company-owned, underground service lateral, wireways or bused gutters will be the point of delivery, and any connectors and terminations shall be supplied and made by the customer.
7. Conductors in a Meter Socket – On an underground service, the center knockout in the bottom of the socket, if provided shall not be utilized. Line conductors shall enter through the knockout provided at the left side of the bottom horizontal surface of the meter socket. The line conductors shall be routed along the outermost edges of the meter socket allowing for ground settling, which could pull the line conductors down. Either the knockout on the right side of the bottom horizontal surface, the lower knockout on the right vertical surface, or the lower knockout on the back vertical surface of the meter socket may be used for load conductors. Load conductors shall not exit the left side of the meter socket. Refer to the Illustrations Section, **Drawings SC-140, SC-150, and SC-170**. Phone loops, cable TV conductors, grounding clamps, etc. shall not be attached to the service riser or meter housing. Line Side conductors shall be terminated by the customer in CO, MN, ND, SD. In WI and MI the Company will terminate the line side conductors. In TX and NM, the Company will terminate the line side conductor, except in multiple meter installations.

4.3.2 Underground System – Primary Voltage (Above 480 Volts)

Because of safety precautions, which must be exercised in the utilization of energy at voltages in excess of 480 volts, the Company shall be consulted in regard to service entrance, transformer location, and meter installation details for this class of service **in advance of construction and/or purchase of equipment**. Refer to the Illustrations Section, **Drawings PM-20, PM-30 and PM-40** for customer-owned primary switchgear and **Drawing CR-100** for primary meter cabinet clearance requirements.

Company Owned Service Conductors in Conduit

4.4 SERVICE LATERAL SIZES (for balanced load):

PAD-MOUNTED TRANSFORMERS		
KVA	Copper	Aluminum
208 Grd Y/120 Volt		
75	1 - 4/0	1 - 500
150	2 - 500	2 - 500
300	3 - 500	2 - 750
500	4 - 500	4 - 750
750	6 - 500	5 - 750
1000	8 - 500	7 - 750
240/120 Volt Δ (1)		
225	2 - 500	1 - 750
300	2 - 500	2 - 500
500	4 - 500	3 - 750
750	6 - 500	5 - 750
1000	8 - 500	6 - 750
480 Grd Y/277 Volt		
75	1 - 1/0	1 - 1/0
150	1 - 4/0	1 - 500
300	1 - 500	2 - 500
500	2 - 500	2 - 500
750	3 - 500	3 - 750
1000	4 - 500	4 - 750
1500	6 - 500	5 - 750
2000	7 - 500	6 - 750
2500	8 - 500	7 - 750
240/120 Volt 1Ø		
167	2 - 500	2 - 500

4.5 CONDUIT SIZING CHART:

The following is a list of pipe or duct size to be used for cable installations in conduit. This table is based on 40% maximum pipe fill.

Cable Size	Voltage	# Cond/Conduit	Pipe Size (I.D.)
1/0-2-1/0	600 V	1 Set	2" PVC or PE or 2" flex
4/0-2/0-4/0	600 V	1 Set	3" PVC or PE or 3" flex
350-4/0-350	600 V	1 Set	4" PVC or PE
350 AL/CU	600 V	1-5	5"
350 AL/CU	600 V	6-8	Two 5"
750 AL/CU	600 V	1-4	5"
750 AL/CU	600 V	5-8	Two 5"

NOTE: Conduit or conduit fittings made from a ferrous material may not be used when separating three-phase runs into separate conduits.

4.6 TRANSFORMER INSTALLATIONS – NETWORK VAULTS

For non-network areas, transformer vaults will not be permitted.

The determination of facility type and routing will be made by the Company to be consistent with the characteristics of the territory in which service is to be rendered and the nature of the Company's existing facilities in the area.

Prior approval is required for all network vaults and the following rules shall apply:

1. Where extensive building remodeling is being done and it is necessary to provide a vault for transformers and related equipment, all necessary vault construction, including relocating facilities, shall be accomplished by the building owner at no cost to the Company.
2. All transformer vaults shall be constructed in accordance with the latest revision of the *National Electrical Code*[®], any other applicable codes and the Company's specifications. The customer, upon request by the Company, shall authorize in writing that the Company may declare and operate the vault and equipment therein as a Company Substation.
3. In addition to the requirements of the *National Electrical Code*[®], the following general requirements shall be observed:
 - a. Access for Company personnel and equipment is required. Such access shall be available to Company personnel at all times. The customer shall provide a hasp or other suitable means to accommodate the Company's lock.
 - b. If access to the vault does not permit the use of Company equipment for removal, relocation, and installation of vault facilities, the customer shall provide the means to remove, relocate, and install the Company's facilities.
 - c. The vault shall be suitable illuminated and a convenience outlet shall be provided at the expense of the customer. The light control switch and convenience outlet shall be located inside the vault and shall be connected to the unmetered bus.
 - d. The customer's equipment, fuses, etc. shall not be installed in the vault.
 - e. The customer shall provide a Company approved separate ventilation system to the outside air. The vault's ventilation ducts shall not, under any circumstance, be tied into the building ventilation system.
 - f. Vaults shall be provided with a retaining or holding tank system to collect any oil spillage. Any water entering the vault must be drained away from the vault separate from any oil. Provisions shall be made to pump any oil collected in the sump from the vault.
 - g. Because of the variety of special problems arising during the construction of building vaults, only the most general specifications covering their design and arrangements are presented herein. The Company shall be consulted well in advance of any proposed project.
 - h. The Company will not energize any building vault transformer for temporary or permanent service until all vault specifications are met, a final checklist of vault specifications is approved by the assigned Company Area Engineer, and the vault has been turned over to the Company for occupancy.

4.7 TRANSFORMER INSTALLATIONS – PAD-MOUNTED

The Company will provide an outdoor pad-mounted transformer for service to the customer's facilities such as shopping centers, office buildings, schools, large apartment buildings, etc. under the following conditions:

1. The customer's facilities shall be located in an area not presently served or expected to be served from the Company's underground network system. The Company reserves the right to define areas to be served by secondary network systems.
2. The Company will own, operate, and maintain the primary underground installation between the adjacent distribution facilities and the transformer, including the primary cable, ducts, transformer, and protective equipment.
3. The customer shall provide a level, obstruction free, compacted area, which is to final grade, for the installation of the Company's pad and transformer. Oil filled equipment must be level to keep the live parts under oil. If any corner of the tank has settled to be lower than two (2) inches from any other corner, the installation must be reset to a level position. In areas near buildings where earth has been disturbed, the customer shall provide firm soil conditions under pad area to prevent settling of the pad. Native soils can be used if the required compactions can be obtained (at least 2000 pounds/square foot compaction). In cases where the adequacy of the base may be doubtful, the Company may require a "Certificate of Adequacy" from a qualified testing laboratory.
4. The Company will make and maintain all connections at the transformer terminals. No customer-owned switches, fuses, etc. may be located within a fenced area designed to contain a transformer installation without written approval of the assigner Company Area Engineer.
5. The Property shall be to final grade (± 6 inches) except at the equipment location, which shall be to exact final grade. The property must be level and clear for ten (10) feet to allow for operation and maintenance of the pad mounted equipment. Property pins shall be in place with the structure staked or the founding in, prior to installation of the pad-mounted equipment and splice boxes.
6. The Company shall be consulted well in advance of any proposed project.
7. If, in the judgment of the assigned Company Area Engineer, the selected location for the installation of the pad-mounted equipment is not adequately protected from traffic, or when directed by the Public Authority, the customer shall furnish and install either a fence guardrail or guard posts to protect the pad-mounted equipment installation. At the customer's request, the Company may elect to furnish and install the guardrail or guard posts, and the customer shall accept such cost as non-standard design on a non-refundable basis, not subject to Construction Allowance. The installation shall conform within the practical limits to the Illustrations Section, **Drawing CR-90**.

Further details relating specifically to transformers can be found in Section 5. Refer to the Illustrations Section, **Drawings CC-10, CC-30, CC-40, CC-50, CR-20, CR-30, CR-40, CR-50, CR-60 and CR-90** for typical pad-mounted transformer installation and clearance requirements.

4.8 POINT OF DELIVERY

The point of deliver is the point where the Company's electric facilities are first connected to the electric facilities of the customer. The point of delivery for the various classification of service is shown throughout the Illustrations Section.

It is the policy of the Company to own, operate, and maintain the electric distribution facilities up to the point of delivery. This policy is applicable to service rendered from either overhead or underground facilities. All such facilities will be installed in accordance with the Company's Line Extension Policy and Rules and Regulations as filed with the Commission.

4.9 CUSTOMER-OWNED SERVICE CONDUCTORS
(Not Applicable in WI/MI)

The number and size of customer-owned conductors that may be terminated to Company facilities is limited by the type of installation as follows:

1. Overhead-to-Overhead:

- a. Service entrance rises on a building are limited to a maximum number of six (6), with a single set of conductors in each riser.
- b. The conductor size shall not exceed 750 kcmil.

2. Overhead-to-Underground:

- a. A maximum of three U-guard risers per pole (including Company-owned, foreign utility owned and/or customer-owned) shall be attached to a Company pole.
- b. Thirty-two (32) feet of customer owned conductor shall be coiled at the base of Company pole, where applicable. If customer installs conduit from structure to base of pole, customer may install elbow at pole but under no circumstances install any customer owned conduit on Company-owned pole.
- c. Customer-owned conduit at the base of the Company's pole shall not exceed six (6) inches above final grade.
- d. The U-guard riser shall be grouped together and shall not occupy more than 40% of the pole circumference.
- e. Only a single set of conductors shall be installed in each U-guard riser.
- f. The conductor size shall not exceed 750 kcmil.

3. Underground:

- a. Three-Phase Pad-mounted Transformer – The maximum number of secondaries or service runs per phase that are to be served from a three-phase transformer is eight (8). The maximum conductor size shall not exceed 500 kcmil copper or 750 kcmil aluminum.
 - i. A secondary connection cabinet is required when the number of the Customer's secondary conductors exceeds eight (8) runs per phase or the size of the conductors is greater than 500 kcmil copper or 750 kcmil aluminum.
 - ii. When not required, a secondary connection cabinet may also be installed at the customer's discretion.
 - iii. All secondary connection cabinets with or without metering provisions shall be provided by the Customer and placed adjacent to the transformer. Refer to the Illustrations Section, **Drawing CC-10, CC-40, and CC-50.**
 - iv. **Effective March 1, 2016: All secondary connection cabinets with or without metering provisions shall have a three-point latch with provisions for a Company padlock and door(s) shall be hinged on either the left or right side.**

- b. Single-Phase Pad-mounted Transformer – The maximum number of secondaries or services per phase that are to be served from a single-phase transformer is based on cable size. A maximum cable size of 500 kcmil is permitted. For cables 500 kcmil or 350 kcmil a maximum of 4 runs are allowed. For residential applications, a maximum of 4 runs of 350 kcmil plus 2 runs of 4/0 are allowed (total of six (6) runs).
- c. Single-Phase Pedestal – The maximum number of cables in a standard single-phase pedestal, with six-position URD moles, is 15. This includes one secondary feed from the transformer, 4 services, and the ground. The ground wire needs to be installed in its own port on the Neutral URD mole. The maximum conductor size shall not exceed 350 kcmil aluminum. If a street light feed is required, or if any additional services need to be run from the pedestal, an 8 position URD mole shall be used.

4.10 METERING

4.10.1 New Services

The Company will not permit a temporary unmetered service (closed loop/flat tap/jumpered) on new electrical services. Service may be supplied from a temporary meter panel prior to an inspection release on new services. Refer to Section 4.10.3, TEMPORARY SERVICES and the Illustrations Section, **Drawings TM-10, TM-20 and TM-30**.

Before permission will be granted to energize a new service, the Company shall have an application for electric service and an inspection release shall be provided to the Company by the local Public Authority.

Note: In locations where there is no local Public Authority, the customer is exempt from inspection, the licensed electrician or wireman shall submit a signed and dated Xcel Energy Electrical Inspection Certificate to the Company's Builders Call Line attesting that the electrical installation has been completed and installed according to the current National Electrical Code[®], the Xcel Energy Standard for Electric Installation and Use, and any other applicable codes that apply before electric service is energized.

4.10.2 Existing Services

Before a meter will be installed on an existing service, which has been rewired, altered, or repaired, an inspection release shall be received by the Company from the local Public Authority.

Note: In locations where there is no local Public Authority, the customer is exempt from inspection, and/or the service has been shut off or disconnected for more than 365 days (1 year), the licensed electrician or wireman shall submit a signed and dated Xcel Energy Electrical Inspection Certificate to the Company's Builders Call Line attesting that the electrical installation has been completed and installed according to the current National Electrical Code[®], the Xcel Energy Standard for Electric Installation and Use, and any other applicable codes that apply before electric service is energized.

Closed Loop Temporary Unmetered Services are not allowed in MI, MN, ND, SD, TX, NM and WI.

Closed Loop Temporary Unmetered Services for CO Only. The following rules shall apply:

1. For existing services, a temporary unmetered service (closed loop/flat tap/jumpered) may or may not be allowed in the service territory or locale where electric service is needed. Before closing a loop, the customer shall obtain a wiring permit from the local Public Authority and permission from the Company. All wiring shall comply with the *National Electrical Code[®]* and the rules of the local Public Authority.
2. Electric energy used during the period of the closed loop will be estimated and billed at the appropriate rate. The customer of record will be responsible for the energy used.

3. On any wiring installation where a meter has been disconnected, the meter shall not be reconnected by anyone except a Company Representative. Closing a manual bypass mechanism or installing jumpers in the meter socket is not permitted and will be considered a closed loop, which requires prior permission.
4. If any wiring being served on a closed loop is not installed in accordance with the Company's Rules and Regulations, the Company may open the closed loop.

Note: Customers that have been disconnected by non-Company personnel may incur a reconnect fee.

5. The Company may grant permission for a temporary unmetered service (closed loop/flat tap/jumpered) on an existing service for up to a maximum of seven (7) calendar days. Special permission by the Company's local Electric Meter Department is required to extend a closed loop beyond seven days. Permission to close a loop may be obtained in the form of an authorization number by calling the Company Office nearest you. If a temporary unmetered service is not allowed in the service territory or locale where electric service is needed, or if the length of time that temporary service is required exceeds seven (7) days, the customer may contact the Company's Builders Call Line to coordinate temporary meter service. Refer to Section 2.14, XCEL ENERGY LIMITED TELEPHONE DIRECTORY.

4.10.3 Temporary Services

Temporary service may be made available prior to the installation of the permanent meter. Temporary service shall be restricted to as short a time as possible, such as the time necessary for the construction of a building. Temporary service will be provided by the Company in accordance with its established Rate Schedules, Electric Service Connection Policy, and Line Extension Policy. All temporary meters shall be located outdoors.

4.10.3.1 Overhead Temporary Service

The overhead service drop support shall be supplied by the customer in accordance with the requirements shown in the Illustrations Section, **Drawing TM-10** and the additional requirements of this Section. The support shall be within 70 feet of a pole supporting the Company's secondary lines with conductor no larger than 4/0. The support shall be located in such a manner as to clear all utility obstructions. The overhead drop shall overhang only the property owned and controlled by the customer and shall clear all structures and obstacles in accordance with the Illustrations Section, **Drawings CR-70, CR-70A, and CR-130** and the applicable requirements for OVERHEAD SERVICE in Section 4.2. The support shall be installed in such a manner that the installed drop is at a vertical angle of not less than 45 degrees and not closer than ten (10) feet horizontally to the Company's secondary or primary conductors. Temporary meter panels shall not be installed on a Company pole. The ground rod(s) and grounding electrode conductor shall be furnished and installed by the customer and shall comply with 2017 *National Electrical Code*[®] Article 250, or as may be amended.

4.10.3.2 Underground Temporary Service

The underground service lateral and meter support shall be supplied and installed by the customer in accordance with the requirements shown in the Illustrations Section, **Drawing TM-20** and the additional requirements of this Section. The meter support shall be installed outside the utility easement and not less than six (6) feet from the service pedestal. The temporary service lateral conductors shall be an approved type for direct burial installation and installed by the customer in accordance with the *National Electrical Code*[®]. The grounding electrode conductor shall be furnished and installed by the customer and shall comply with 2017 *National Electrical Code*[®] Article 250, or as may be amended. The ground rod(s) shall be furnished and installed by the customer and shall be installed outside of all utility easements.

4.10.3.3 Alternate Underground Temporary Service

Where permitted by the local Public Authority, the underground service lateral, and meter support shall be supplied and installed by the customer in accordance with the requirements shown in the Illustrations Section, **Drawing TM-30** and the additional requirements of this Section. The meter support shall be installed at a distance not less than five (5) feet from the pad-mounted transformer and shall clear all utility easements and underground obstructions, except where allowed in MN with prior approval. The direct buried temporary service lateral conductors shall be an approved type for direct burial installation and installed by the customer in accordance with the *National Electrical Code*[®]. The temporary service conductor shall have a coiled tail of no less than thirty-six (36) inches at the transformer so that terminations may be made within the pad mounted transformer. The grounding electrode conductor shall be furnished and installed by the customer and shall comply with 2017 *National Electrical Code*[®] Article 250, or as may be amended. The ground rod(s) shall be furnished and installed by the customer and shall be installed outside of all utility easements. As an alternative between the utility equipment and the meter housing, three #6 minimum insulated conductors can be run in a liquid tight, flexible, nonmetallic conduit with 1-1/2" liquid tight box connectors. The maximum length of the conduit run should be twelve (12) feet and placed in an area protected from vehicular traffic and mechanical damage.

4.10.3.4 Requirements for Temporary Service

Temporary service shall normally be served from the distribution transformer or service pedestal.

The service address shall be prominently displayed on the temporary service installation. Entry into and connections within all pad-mounted or underground facilities will be made by the Company.

The meter socket shall be furnished and installed by the customer. Temporary service installations shall be braced as shown in the respective Drawings in the Illustrations Section to withstand normal service drop tension and normal use of the facility.

Temporary meter service panels shall not be attached to vehicles or trailers. Refer to the Illustrations Section, **Drawings TM-10, TM-20 and TM-30** for acceptable temporary meter panel designs. In the event that a temporary service installation fails or collapses, it will be disconnected by the Company until repaired by the customer.

4.10.4 Meter Installation and Ownership

All service to a customer will be supplied by a single service (point of delivery) and only one meter will be installed at an address or single unit of a multi-unit building. Only in the event that more than one service is allowed by the Company as detailed in SERVICES in Section 4.1, will the Company install more than one meter.

Only authorized Company employees or qualified individuals authorized by the Company are permitted to connect, disconnect, move or remove meters. All meters, service wires, and other electrical facilities installed by the Company upon the customer's premises for delivering or measuring electrical energy to the customer shall continue to be the property of the Company. All metering equipment owned by the Company and not installed shall be returned to the Company. These facilities may be repaired, inspected, tested, relocated, replaced, or removed by the Company.

In TX/NM only, an oil well pumping service may be provided from a customer-owned overhead transformer bank installed on a customer-owned primary distribution system with prior approval for the Company's local Electric Meter Department. For all new installation, the meter shall be installed on the customer-owned transformer pole.

4.10.5 Classification of Metering

Refer to Section 1 for the definition of Classification of Metering.

The Company classifies its metering installations as:

1. Residential Rate:
 - a. Self-Contained (Hot Sequence required)
 - b. Instrument Transformer (Hot Sequence required)
2. Commercial and Industrial Rates:
 - a. Self-Contained (See Cold Sequence Metering Section for Jurisdictional Requirements)
 - b. Instrument Transformer (Hot Sequence required)
 - c. Temporary Construction (See Cold Sequence Metering Section for Jurisdictional Requirements)

The type of metering used will be determined by the Company based upon: the service voltage, the load supplied, the available fault current, and the applicable Rate Schedule.

Residential service lateral may be extended to a structure containing not more than six (6) residential units provided all meters are grouped at one location and all units are separately metered on residential rates. If house power service (Commercial) is required, then the service lateral shall be installed by the customer, except for MI and WI. In MN only, transformer-rated services and/or services above 400 Amps shall have the service lateral installed by the customer.

All services shall be metered on the secondary side of the Company's transformer unless the applicable Rate Schedule specifies that the service be metered on the primary side of the transformer. The Company may install its meter on either side of the transformer and losses occurring between the point of delivery and the meter will be computed and added to, or subtracted from, the reading of the meter. Company Area Engineering Department and Rate Department approvals are required for Primary Rate installation and will only be considered under extenuating circumstances.

4.10.6 Self-Contained Metering

Single-phase and three-phase services with a total continuous load of 200 amps or less (250 amps max, non-continuous) shall be metered by self-contained meters.

Single-phase and three-phase services with a total continuous load of 200-320 amps (400 amps max, non-continuous) may be metered by either 320 amp self-contained or instrument transformer (CT) metering.

Single-phase and three-phase services where the total continuous load is in excess of, or anticipated to be in excess of, 320 amps (400 amps non-continuous) shall use instrument transformer (CT) metering.

The total amp rating of the main disconnect(s) shall not exceed 250 amps for a 200 amp continuous duty rated meter socket or 400 amps for a 320 amp continuous duty rated meter socket.

All self-contained single position and/or modular (multi-position) meter sockets that are of either single-phase or three-phase design shall be furnished, owned, installed, and maintained by the customer. All self-contained meter sockets shall be Nationally Recognized Testing Laboratory (NRTL) listed and labeled and will be inspected by the local Public Authority for compliance to the *National Electrical Code*® and any other

applicable codes. The construction for the meter sockets shall also conform to the Company's standards as described in Section 4.11, METER SOCKETS.

K-base type meter socket installations are not allowed within the Company's service areas.

*Note: The service entrance conductor intended to be connected to the high-leg of a 3-phase, 4-wire delta-connected system shall be durably and permanently marked at both ends of the conductor by an outer finish that is orange in color in accordance with the 2017 National Electrical Code® Articles 110.15, or as may be amended, and shall be installed in the far right hand position of the meter mounting block. Refer to the Illustrations Section, **Drawings SC-120 and SC-140**.*

4.10.7 Instrument Transformer Metering, Secondary Voltage

Hot Sequence is the required installation method for instrument transformer (CT) metering. A cold sequence disconnecting device is not allowed ahead of a CT cabinet unless required by local Public Authority having jurisdiction, or in multi-unit instances where a single main disconnect may be ahead of a CT compartment.

The maximum metered load shall not be greater than 4000 amps.

The CTs and meter-socket will be supplied, owned, and maintained by the Company and shall be installed by the customer. The instrument transformer compartment in a CT cabinet, service connection cabinet, or switchgear CT compartment, and the necessary conduit and fittings shall be supplied, owned, installed, and maintained by the customer. The customer³ shall terminate the line-side and load-side conductors in the CT cabinet, or switch gear CT compartment. The Company will terminate the line-side conductors and the customer shall terminate the load-side conductors in a secondary connection cabinet. The secondary (metering) conductors will be supplied, owned, install, and maintained by the Company. Customer-owned equipment, other than service conductors, shall not be installed in the space dedicated to instrument transformers.

All current transformers (CTs) shall be installed in a CT cabinet, secondary connection cabinet, or switchgear CT compartment. Refer to Section 4.12, Instrument Transformer Compartments for detailed requirements for instrument transformer compartments.

The following CT installations are not allowed:

1. Rack mounted on mast, pole or side of building using donut or window type CTs.
2. Grecian urn or over-the-bushing type CTs mounted in the Company's distribution transformer.

The CTs shall be installed in such a manner that the secondary (metering) terminals are readily accessible from the door of the CT compartment. The CTs shall be mounted such that the H1 "white dot" marking for polarity is on the line side. When bar-type CTs are installed, the bolts used to make the connections shall be the largest standard diameter that will fit through the holes or slots provided for this purpose.

Conductors in CT cabinets and secondary connection cabinets shall be installed in accordance with the requirements of 2017 *National Electrical Code*® Article 312.6, or as may be amended.

Metering conduit installed below grade (underground) from the meter-socket to the CT cabinet (or compartment) shall be minimum one (1) inch Schedule 80 PVC. Metering conduit installed above grade (above ground) from the meter-socket to the CT cabinet (or compartment) shall be minimum one (1) inch GRC, IMC, or EMT. Metering conduit shall be a continuous run between the meter socket and the CT cabinet. The conduit run shall not exceed twenty-five (25) feet in length. Installations requiring conduit runs greater than twenty-five (25) feet (up to one-hundred (100) feet maximum) may be allowed with prior

³ The Company will terminate the line conductors in the WI and MI service territories.

approval from the Company's local Electric Meter Department. The metering conduit for installations of twenty-five through one-hundred (25-100) feet shall be 1 ¼" minimum GRC, IMC, EMT. If the conduit run exceeds 25 feet in length, the total degrees of bends shall not exceed 180, the equivalent of two 90 degree bends. Junction boxes, conduit bodies (e.g. LBs), or other devices are not allowed without prior approval from the Company's local Electric Meter Department.

The meter socket shall be bonded with a separate bonding conductor in accordance with 2017 *National Electrical Code*® Article 250, or as may be amended. **Check with Company's local Electric Meter Department for bonding requirements.**

4.11 METER SOCKETS

Purchasing, installing, connecting, and maintaining self-contained meter sockets shall be the responsibility of the customer.

All meter sockets shall be Nationally Recognized Testing Laboratory (NRTL) listed and labeled, used in accordance with their labeling, installed per the 2017 National Electrical Code®, or as may be amended, and meet any code requirements that may be enforced by the local Public Authority.

All single and multiple position meter sockets installed on the Company's system shall meet the Company's standards for these devices as listed on the following pages. Company Electric Meter Personnel are instructed not to install a meter at a location where the meter socket does not comply with **all criteria listed below**. Meter sockets will be considered un-approved unless they adhere to this criteria.

1. All meter sockets shall be constructed from steel or aluminum. Panels constructed from non-metallic materials are not allowed.
2. Temporary cover plates for meter sockets shall be constructed from a non-metallic material.
3. All single-phase and three-phase meter sockets shall be rated for either 200 or 320 continuous duty and shall be equipped with an approved lever-actuated, locking-jaw, bypass constructed such that the bypass lever cannot be in the bypass position with the socket cover installed. The bypass handle shall be located on the right side of the meter block when facing the meter block. The only approved bypasses are the Talon (formerly Landis & Gyr) HQ, Square D, Milbank HD (Heavy Duty), Eaton MSL (with "XCH" suffix), and Cooper B-Line.

Note: Effective April 15, 2015 Blue Handled Eaton MSL (Meter Socket Lever Bypass) single-phase and three-phase meter sockets using a "XCH" suffix are approved for use.

Note: Effective October 1, 2014 all temporary single-phase commercial services (e.g. construction temporary), shall have a locking jaw, lever bypass.

4. All meter sockets shall be equipped with an insulating, track-resistance polycarbonate safety shield.
5. All single-phase and three-phase, three-wire sockets shall have a fifth terminal connected to the neutral within the socket with minimum #16 AWG wire. The fifth terminal shall be installed in the 9 o'clock, rather than the 6 o'clock, position if the meter block design allows. The Company will not furnish or install the fifth terminal.
6. Three-phase, four-wire sockets shall have the seventh terminal connected to the neutral within the socket with a minimum #16 AWG wire.
7. Meter sockets shall have ringless style covers. No screws, studs, or wing nuts are allowed to secure the meter covers.

8. Sealing means shall provide for a plastic padlock seal with a 0.047" diameter shackle and a key type padlock with a $\frac{9}{32}$ " shackle.
9. 320 amp meter sockets shall have an anti-inversion clip installed in the top right terminal.

4.11.1 Self-Contained Individual Meter Sockets

1. Individual meter sockets shall be constructed from steel or aluminum. Panels constructed from non-metallic materials are not allowed.
2. Individual meter sockets, excluding side-wired type which are bussed on the line-side of the meter, used in all installations shall have the following minimum dimensions:
 - a. 200 amp – 19" height x 13" width
 - b. 320 amp – 26 $\frac{1}{2}$ " x 13" width

4.11.2 Self-Contained Multiple Metering Panels:

1. Multiple metering panels shall be constructed from steel or aluminum. Panels constructed from non-metallic materials are not allowed.
2. Multiple metering panels which are bused on the line-side of the meter shall have the following minimum dimension in the metering section:
 - a. 200 amp – 10" height x 9 $\frac{3}{4}$ " width (height measured from top to bottom of a single meter compartment).
 - b. 320 amp – 13" height x 11" width
3. Each meter socket shall have an individual ringless cover with sealing provisions. No screws, studs, or wing nuts are allowed to secure meter covers.
4. The panel shall have permanent barriers to isolate the customer's disconnect switch and wiring from the metering areas.
5. Each line-side compartment shall have provisions for a Company seal, whether or not the compartment is designed to house a meter.
6. No multiple metering panels shall have a door that completely encloses the utility metering.

4.11.3 Self-Contained Combination Metering Devices:

1. Combination metering devices, such as meter/main and meter/panel, shall be constructed from steel or aluminum. Panels constructed from non-metallic materials are not allowed.
2. Combination metering devices, excluding side-wired type which are bused on the line side of the meter, used in all installations shall have the following minimum dimension in the metering section:
 - a. 200 amp – 9 $\frac{1}{2}$ " height x 13" width (height measured from top of enclosure to center of meter block).
 - b. 320 amp – 13 $\frac{1}{4}$ " height x 13" width (height measured from top of enclosure to center of meter block).

3. Combination metering devices shall have permanent barriers to isolate the customer's disconnect switch and wiring area from the metering area.
4. Combination metering devices shall have separate covers on the customer's disconnect switch and wiring area and on the metering area.

4.11.4 Self-Contained Metering Pedestals:

1. Metering pedestals shall be constructed from steel or aluminum. Panels constructed from non-metallic materials are not allowed.
2. Metering pedestals that are factory wired type or bused on the line side of the meter, used in all installations shall have the following minimum dimension in the metering section:
 - a. 200 amp – 9 ¾" width
 - b. 320 amp – 11" width
3. Pedestals shall be furnished, installed, and maintained by the customer.
4. Pedestals shall meet Company and applicable code requirements
5. Pedestals shall be adequately supported to maintain the vertical alignment of the meter in a level and plumb position throughout the life of the installation.
6. Metering pedestals with factory installed disconnecting means, shall have permanent barriers to isolate the customer's disconnect switch and wiring are from the metering area.
7. Metering pedestals shall have separate covers on the customer's disconnect switch, wiring area and on the metering area.
8. The utility metering compartment door shall be hinged either on the left or right side of metering pedestal. Top hinged doors require prior approval from the local Electric Meter Department. A locking mechanism shall be provided to maintain the door in an open position.
9. Customer owned equipment other than service conductors, shall not be installed in the space dedicated to the utility metering compartment.
10. Sockets shall have ringless style covers. No screws, studs or wing nuts are allowed to secure the meter socket covers or metering compartment.
11. Pedestals that have the meter socket located inside a metering compartment enclosure shall have an 8" x 8" Lexan viewing window installed.
12. Pedestals shall meet additional requirements shown in the Illustrations Section, **Drawings SC-60 and SC-70.**

4.11.5 Instrument Transformer Meter Sockets

The Company will furnish the instrument transformer meter sockets. The Company shall be contacted first to determine the rate, load, and service voltage. The customer should contact the Company's local Electric Meter Department to obtain metering equipment and to coordinate meter installation.

4.12 INSTRUMENT TRANSFORMER COMPARTMENTS

4.12.1 CT cabinets

In addition to the requirements in Section 4.10.7, Instrument Transformer Metering, Secondary Voltage, the following requirements shall also be met:

1. The CT cabinet (enclosure) shall meet a minimum of NEMA 3R standards.
2. The maximum connected load shall not be greater than 4000 amps per metered service.
3. The CT cabinet shall be Nationally Recognized Testing Laboratory (NRTL) listed and labeled as a CT enclosure (UL and/or Third-party certification).
4. CT cabinet rated from 400 to 800 amps shall have mounting provisions for bar-type CTs. Refer to the Illustrations Section, **Drawing TR-40**.
5. CT cabinets rated from 801 to 4000 amps shall have a removable bus section with a twelve (12) inch minimum length, five (5) inch maximum width, and an insulated CT support which will accommodate window-type CTs. The removable bus section shall have an enclosed screw type compression terminal to accommodate a minimum #12 AWG metering potential conductor on the line-side section of the bus. Refer to the Illustrations Section, **Drawing TR-40**.
6. The CT cabinet shall be furnished with factory installed landing pads and lugs for phase and neutral conductors.
7. The neutral bus shall have a neutral lug which will accommodate one #12 AWG solid through two #10 AWG stranded wire(s) for the metering neutral conductors.
8. All instrument transformer compartments shall have barriers between adjacent areas.
9. The door shall be hinged either on the left or right side and be equipped with a hasp for a Company padlock with a 5/16" diameter shackle. **Effective March 1, 2016**, latching methods shall utilize captive fasteners. Studs with wing nuts are **not** allowed.
10. The installation height of the CTs shall be between two (2) feet minimum and six (6) feet maximum measured from the center of the CTs to final grade. The minimum clearance from the bottom of a wall-mounted CT cabinet to final grand shall be one (1) foot.
11. The service entrance conductor connected to the high-leg of a three-phase, four-wire delta system shall be durably and permanently marked at both ends of the conductor by and outer finish that is orange in color in accordance with 2017 *National Electrical Code*[®] Article 110.15, or as may be amended, and shall be installed in the right-hand phase position for vertical bus or the bottom phase position for horizontal bus in the CT cabinet.
12. In TX and NM only. On some types of 400 and 800 amp bar-type CT cabinets, the neutral bus bar can be physically relocated to the center phase position for use in a three-phase, three-wire corner-grounded system. The customer shall furnish and install the bus work on the grounded (center) phase.
13. In WI and MI only. For overhead services, the line-side conductors shall enter and terminate in the top half of the CT cabinet, and the load-side conductors shall exit and terminate in the bottom half. Likewise, for underground services, the line-side conductors shall enter and terminate in the bottom half of the CT cabinet, and the load-side conductors shall exit and terminate in the top half. Neither the line-side nor the load-side conductors shall cross the horizontal centerline of the CT cabinet.

14. For WI and MI only, refer to the table below for CT cabinet minimum dimensions.

DIMENSIONS FOR WALL-MOUNTED CT ENCLOSURES AND SWITCHGEAR
(WI AND MI ONLY)

Ampacity	Minimum Number of Conductor Terminals to Provide	Vertical Bending Space (1Ø & 3Ø)	Depth (3Ø)	Depth (1Ø)	Width (3Ø)	Width (1Ø)
400	1	18"	10"	10"	30"	24"
600	2	18"	10"	10"	30"	24"
800	2	24"	12"	10"	32"	24"
1000	3	24"	12"	----	32"	----
1200	4	27"	12"	----	32"	----

Refer to the Illustrations Section, **Drawings TR-20 and TR-40**

4.12.2 Secondary Connection Cabinets

Single point services to multiple buildings under single ownership may be metered with a pad-mounted secondary connection cabinet with or without a customer disconnect switch. The use of a secondary connection cabinet with a customer disconnect switch allows the customer the ability to de-energize his own service for equipment maintenance without calling the Company to schedule an outage. The secondary connection cabinet shall be located adjacent to the distribution transformer. **Secondary connection cabinets shall not be used to serve single-phase or temporary services**

All secondary connection cabinets shall have a removable bus link section, for each phase and the neutral bus, regardless where the instrument transformers are installed, effective January 1, 2018. When a secondary connection cabinet is utilized, all Company owned conductors exiting the transformer shall be terminated in the secondary connection cabinet and customer owned wires shall not be terminated in the Company transformer. The single and only point of delivery is the secondary connection cabinet. All secondary connection cabinets shall have adequate working clearances and escape route with doors open. Per OSHA 1910.303(h)(4)(i), at least one entrance not less than 610 mm (24 in.) wide and 1.98 m (6.5 ft.) high shall be provided to give access to the working space about electric equipment. Refer to the Illustrations Section, **Drawings CC-20, CC-30, CC-40, and CC-50.**

Note: Refer to Section 4.1, SERVICES and also Section 4.10.4, Meter Installation and Ownership for clarification on the allowable number of service and metering point.

In addition to the requirements in Section 4.10.7, Instrument Transformer Metering, Secondary Voltage, the following requirements shall also be met:

1. All buildings shall be served from the same transformer.
2. The maximum connected load shall not be greater than 4000 amps per metered service.
3. Secondary connection cabinets from 400 to 800 amp rating shall have mounting provisions for bar-type CTs. Refer to the Illustrations Section, **Drawing TR-40.**
4. Secondary connection cabinets from 801 to 4000 amps shall have a removable bus section with a twelve (12) inch minimum length, five (5) inch maximum width, and an insulated CT support which will accommodate window-type CTs. The removable bus section shall have an enclosed screw type compression terminal to accommodate a minimum #12 AWG metering potential conductor on the line-side section of the bus. Refer to the Illustrations Section, **Drawing TR-40.**

5. The neutral bus shall have a neutral lug which will accommodate one # 12 AWG solid through two #10 AWG stranded wires for the metering neutral conductors.
6. The door(s) shall be hinged either on the left or right side and be equipped with a three-point latch with provisions for a Company padlock with a 5/16" diameter shackle.
7. The installation height of the CTs shall be between two (2) feet minimum, and six (6) feet maximum measured from the center of the CTs to the bottom of the cabinet.
8. The phase arrangement on three-phase installations shall be A, B, C front-to-back, top-to-bottom, left-to-right when viewed from the front of the equipment.
9. IN TX and NM only. On some types of 400 and 800 amp bar-type CT compartments, the neutral bus bar can be physically relocated to the center phase position for use in a three-phase, three-wire, corner-grounded system. The customer shall furnish and install the bus work on the grounded (center) phase.

The customer shall install the pad and pad-mounted secondary connection cabinet in accordance with the drawings listed in CC "Connection Cabinet" of the Illustrations Section.

4.12.3 Switchgear CT Compartments

In addition to the requirements in Section 4.10.7, Instrument Transformer Metering, Secondary Voltage, the following requirements shall also be met:

1. Switchgear CT compartments from 400 to 800 amp rating shall have mounting provisions for bar-type CTs. Refer to the Illustrations Section, **Drawing TR-40**.
2. Switchgear CT compartments from 801 to 4000 amps shall have a removable bus section with a twelve (12) inch minimum length, five (5) inch maximum width, and an insulated support which will accommodate window-type CTs. The removable bus section shall have an enclosed screw type compression terminal to accommodate a minimum #12 AWG metering potential conductor on the line-side section of the bus. Refer to the Illustrations Section, **Drawing TR-40**.
3. The maximum connected load shall not be greater than 4000 amps per metered service.
4. A metering neutral lug, which will accommodate one #12 AWG solid through two #10 AWG stranded wires for the metering neutral conductors, shall be available near the front of the CT compartment so that it can be safely accessed even if the switchgear is energized.
5. All instrument transformer compartments shall have barriers between adjacent areas.
6. The door shall be hinged either on the left or right side and be equipped with a hasp for a Company padlock with a 5/16" diameter shackle. **Effective March 1, 2016**, latching methods shall utilize captive fasteners. Studs with wing nuts are **not** allowed.
7. The installation height of the CTs shall be between two (2) feet minimum and six (6) feet maximum measured from the center of the CTs to the bottom of the switchgear.
8. The CT compartment shall have a minimum clearance of one (1) foot clearance from the bottom of enclosure door to final grade.
9. The phase arrangement on a three-phase installation shall be A, B, C front-to-back, top-to-bottom, left-to-right when viewed from the front of the switchgear, except for a three-phase, four-wire delta system in accordance with the 2017 *National Electrical Code*[®] Article 408.3(E) Exception, or as may

be amended. The high-leg of a three-phase, four-wire delta system shall be installed in the right-hand phase position for vertical bus or the bottom phase position for horizontal bus in the switchgear CT compartment.

10. In TX and NM only. On some types of 400 and 800 amp bar-type CT compartments, the neutral bus bar can be physically relocated to the center phase position for use in a three-phase, three-wire corner-grounded system. The customer shall furnish and install the bus work on the grounded (center) phase.

11. For WI and MI only, refer to the table below for switchgear CT compartment minimum dimensions.

DIMENSIONS FOR SWITCHGEAR CT COMPARTMENTS (WI AND MI ONLY)

Ampacity	Minimum Number of Conductor Terminals to Provide	Vertical Bending Space (1Ø & 3Ø)	Depth With Neutral Bus In Plane	Depth With Neutral Bus Offset	Width With Neutral Bus In Plane	Width With Neutral Bus Offset
1600	5	36"	14"	18"	36"	30"
2000	6	36"	14"	18"	36"	30"
2500	7	42"	14"	18"	36"	30"
3000	8	42"	14"	18"	36"	30"
4000	8	42"	14"	18"	36"	30"

Refer to the Illustrations Section, **Drawing TR-30 and TR-40.**

4.13 PRIMARY METER INSTALLATIONS

Company-owned primary metering installation shall be located on the customer's property within a distance of five (5) feet to twenty-five (25) feet from the access point. Primary metering installations require coordination between the customer and the Company regarding technical details and location. Service at distribution primary voltage requires special engineering considerations; therefore, it is necessary to determine availability of this type of service. **The Company Representative shall be consulted well in advance of the time the service will be required so that all design and construction work of both parties may be properly coordinated. The Company's Electric Meter Engineering Department shall also be contacted in advance of design, construction, and/or purchase of equipment.** Electric Meter Engineering will provide a set of specifications upon customer request. This will reduce the risk of project delays or expensive changes during construction.

Primary voltage installations use both current and voltage instrument transformer regardless of the load current.

4.13.1 Overhead

The primary meter installation will be installed on a Company-owned pole.

4.13.2 Underground

The ownership of the primary metering enclosure depends upon the service territory.

The primary meter installation may be in a Company-owned primary metering cabinet, a customer owned primary metering cabinet or a customer-owned primary rated switchgear.

Pre-approval of equipment drawing by Electric Meter Engineering is required for the use of customer-owned primary metering. Equipment drawing detailing all customer-owned primary metering shall be submitted to Electric Meter Engineering for written approval in advance of design, construction, and/or purchase of equipment. Refer to the Illustrations Section, **Drawings PM-10, PM-20, PM-30, and PM-40.**

4.14 METER LOCATION AND INSTALLATION

4.14.1 Meter Location

The customer shall provide and maintain, without cost to the Company, an easily accessible metering location. The Company will locate an acceptable point of delivery and meter location. No wiring dependent upon a meter location shall be started until a definite meter location has been established. The Company will not be responsible for the relocation of the service attachment, service entrance, or metering equipment resulting from an improper location chosen by the customer, which does not meet the requirements of the Company.

All self-contained and transformer-rated meters, including CT enclosures, shall be installed outdoors. The Company will determine meter location in all instances. All meters originally installed outdoors that, due to alterations or additions to the building, become enclosed within the building structure (e.g. enclosed patio or garage), where access through a doorway is required, shall be relocated to an outdoor location designated by the Company's local Electric Meter Department.

The relocated service entrance installation shall conform to current Company standards.

Requests for multiple indoor metering may be allowed if it is not practical to install the metering outdoors, **WITH PRIOR WRITTEN APPROVAL BY SUBMITTING AN EXCEPTION FORM AS DESCRIBED IN THE FOREWORD OF THIS DOCUMENT.**

If approved, indoor meter installation shall meet the following requirements:

1. The customer shall provide Company personnel access to the building and meter room(s) at all times for reading, testing, and other maintenance and/or safety purposes.
2. Meters shall be grouped together in a common room or other suitable space with direct access from outside the building (or common area).
3. The customer must provide a suitable keyless entry for Company access. Customer shall provide the Company with the keyless-entry code (or key code) prior to energizing the service. Lock boxes are not allowed.
4. Customer may be required to provide phone lines for meter reading purposes if the building is not readily accessible at all times.
5. The meter room(s) shall be dedicated to utility metering only. **Meter room(s) are not permitted to be used as customer's storage area.**

Mobile homes, construction trailers, and those buildings not intended as dwelling units, such as, but not limited to, contractor's onsite offices, sales offices, mobile studios, mobile stores, or construction job dormitories intended for sleeping purposes only, shall have the meter socket located adjacent to and in line of sight of the structure it supplies. The meter sockets shall not be mounted on or attached to the structure. Refer to 2017 *National Electrical Code*[®] Article 550.2, or as may be amended.

Manufactured homes may have the meter socket attached to the structure provided the structure meets the definition of a Manufactured Home as defined in 2017 *National Electrical Code*[®] Article 550.2, or as may be amended, and meets the requirements of 2017 *National Electrical Code*[®] Article 550.32(B), or as may be amended. The manufacture home shall be installed on and secured to a permanent foundation and shall provide the necessary structural support for the meter socket attachment.

Meters originally installed in accessible locations satisfactory to the Company, which become inaccessible by virtue of alterations or new construction, shall be reinstalled at a point designated by the Company at the expense of the property owner.

In locations with heavy snowfall or ice loading and in locations above 6000 feet in elevation, all meters shall be installed on the gable or non-drip side of a building or other structure, and there shall be no adjacent rooflines, which will drip directly on or towards a neighboring meter installation. Any installation deemed unsafe by the Company may be disconnected.

Meters shall be installed:

1. In a location that will be easily accessible to Company personnel at all times for reading and maintenance.
2. In a location where they will be safe from damage.

Meters shall not be installed:

1. On fences, mobile homes, or construction trailers.
2. Where the meter will, in the Company's opinion, interfere with traffic on sidewalks, driveways, hallways or passageways.
3. Where the meter will, in the Company's opinion, obstruct the opening of doors or windows.
4. In a location that may, in the Company's opinion, be considered hazardous.
5. Where meter reading or servicing may, in the Company's opinion, become impracticable.

4.14.2 Meter Installation

Installation of line-side (ahead of the meter) facilities shall be in conformance with the Illustrations Section drawings.

Installation of the meter socket is the responsibility of the customer. Meter sockets and associated equipment shall be mounted securely and plumb. Expansion bolts, plugs, or anchors shall be used where attachment is made to masonry, concrete, or plaster walls.

The meter sockets, service mast, service riser, or any conduit containing conductors on the line-side of meters shall not be covered or concealed except when necessary to pass through roof eaves or through floor structures within a building.

The customer shall provide suitable protective equipment approved by the Company if a meter location puts the meter at risk of damage from any means, including falling ice or snow from roof overhangs.

All line-side unmetered conductors shall be in a continuous length of conduit from the point of delivery to the meter socket, cold sequence disconnect, or CT cabinet. No conductors other than line-side conductors shall be permitted in line-side conduits, troughs, or lug landings, Junction boxes, conduit bodies (e.g. LB's), or other devices are not allowed without specific approval from the local Electric Meter Department. Wireways and bused gutters with provisions for a Company padlock may be used on installations of two or more meters.

4.14.3 Meter Socket Identification

The unit number shall be plainly marked on all commercial services, meter pedestals, remote meter locations, and all multiple residential services by a permanent, durable means at all meter sockets **and** corresponding main service breaker, tenant panel board, doorway or entrance to the apartment, office, store, or other premise. The method of identifying the corresponding unit on the meter socket is listed below (Sections 4.14.4 and 4.14.5):

4.14.4 Meter Socket Identification Requirements for CO

The meter sockets shall be marked with a stamped brass, aluminum, or stainless steel tag securely attached to the meter socket. The stamped tag shall be attached to the exterior, non-removable portion of the meter socket or at the individual meter main disconnect. Any other means of identification is not acceptable.

4.14.5 Meter Socket Identification Requirements for (MI, MN, ND, NM, SD, TX, and WI)

The meter socket shall be marked with a stamped plastic, brass, aluminum, stainless steel tag, or a weather resistant plastic/vinyl sticker securely attached to the meter socket. The stamped tag or permanent plastic/vinyl sticker shall be attached to the exterior, non-removable portion of the meter socket and at the individual meter main disconnect. Any other means of identification is not acceptable.

Note: Meters will not be installed until all units are permanently marked.

4.15 METER MOUNTING HEIGHTS

The mounting heights of meters, measure from the center of the meter to final grade or platform outdoors, or to the floor when installed indoors, are as follows:

1. Single meter sockets:
 - a. Self-contained or transformer-rated ----- 4' minimum to 6' maximum
 - b. Meter pedestals ----- 4' minimum to 6' maximum
2. Multiple meter sockets, vertically aligned:
 - c. Indoor ----- 2' minimum to 6'-6" maximum
 - d. Outdoor ----- 3' minimum to 6'-6" maximum

The height of multiple meter sockets, either horizontally or vertically aligned, shall be evenly distributed from the center point of the meter stack between the upper and lower height limitations.

If a platform is used to achieve the required mounting heights for a meter installation, it shall be permanent and accessible by a stairway. The minimum horizontal dimensions of the platform shall meet the *National Electrical Code*® requirements for working space as specified under Section 4.16, METER CLEARANCES and the Illustrations Section, **Drawing CR-120**.

Mounting heights are also shown throughout the drawings in the Illustrations Section.

4.16 METER CLEARANCES

The minimum depth of working space in front of meter equipment shall be 3', 3' 6", or 4' in accordance with 2017 *National Electrical Code*® Article 110.26(A)(1) and Table 110.26(A)(1), or as may be amended. The minimum width of the working space in front of meter equipment shall be the width of the meter equipment or 2' 6", whichever is greater, in accordance with 2017 *National Electrical Code*® Article 110.26(A)(2), or as may be amended. No customer-owned equipment may be installed directly in front of metering equipment which includes cold sequence disconnects, CT cabinets, secondary connections cabinets, switchgear CT compartments, and meter sockets.

Refer to the Illustrations Section, **Drawing CR-120** for clearance (working space) requirements.

4.16.1 Clearances from Gas Meter Sets

Minimum Clearances from Gas Meter Sets and Sources of Ignition	
Minimum clearance between gas meter sets and sources of ignition.	There shall be a 3' radial minimum clearance between the discharge/release point of the relief device line or regulator vent or connected terminal outlet piping of all gas meter sets and sources of ignition. Any discharge/release point of the relief device line or regulator vent or connected terminal outlet piping must be located outside where the gas can escape freely into the atmosphere and away from any opening into the building.

Minimum Working Clearances from Gas Meter Sets	
Minimum working clearance between gas meter sets and electrical equipment. As an example: electric meter, breaker box, air conditioning unit, electric outlet, etc.	No electrical equipment shall be installed directly above a gas meter or in an area 12" on either side of a gas meter set.
Working clearance between gas meter sets and other obstructions.	In all cases, sufficient working space (3' preferred) in front of and on either side of the gas meter and associated piping shall allow access for inspection, reading, replacement, or necessary maintenance.

Minimum Clearances from Gas Meter Sets and Common Building Openings or Mechanically Induced Air Intakes	
Common building openings (doors, garage doors, windows, crawl space, attic and dryer vents, etc.)	There should be a 3' radial preferred minimum clearance between the discharge/release point of the relief device line or regulator vent or connected terminal outlet piping of all gas meter sets and common building openings.
Mechanically induced air intakes	There shall be a 6' radial minimum clearance between the discharge/release point of the regulator vent or relief line vent or connected terminal outlet piping of all gas meter sets and mechanically induced air intakes. The 6-foot clearance is measured from the vent or source of release (discharge port), not from the physical location of the meter set assembly.

4.17 COLD SEQUENCE METERING

4.17.1 Cold Sequence Requirements for MN, MI, ND, SD, and WI

Cold sequence metering **is not allowed** on commercial and industrial self-contained 480 volt meter installations, for both single-phase and three-phase applications unless required by Local Public Authority having jurisdiction.

4.17.2 Cold Sequence Requirements for TX and NM

Cold Sequence metering **is not allowed** in the TX and NM Service Territory. "Hot Sequence Metering" will be the required installation method for all metering applications. Hot Sequence Metering is defined as the electric meter is connected directly to the service conductors without the use of a fault-current limiting disconnect or meter safety-switch device between the electric meter and the supply source.

4.17.3 Cold Sequence Requirements for CO

The cold sequence disconnect shall be treated as a meter disconnect in accordance with 2017 *National Electrical Code*[®] Article 230.82(3), or as may be amended.

All new, rewired, or altered commercial and industrial self-contained meter installations (all installations other than residential) for services up to 320 amp, single-phase and three-phase, require the installation of a fusible load-make/load-break safety or pullout switch with fault current-limiting fuses ahead of each individual meter. Commercial and industrial installations may be subject to available fault currents up to 100,000 symmetrical RMS amps. Current-limiting fuses shall be selected to limit faults to 10,000 symmetrical RMS amps at the meter.

Exception 1: A fault current-limiting circuit breaker may be utilized in lieu of a fusible load-break safety or pullout switch if pre-approved by the Company's Electric Meter Engineering Department. The request shall be submitted in writing through the written exception process and include a fault-current analysis report by a registered professional engineer. All calculations shall be based upon the worst-case transformer percent resistance, percent reactance, and percent impedance values shown in Section 5, Tables I through V.

Exception 2: Multiple commercial tenant meter sockets are permitted to have a single fusible current-limiting main disconnect ahead of the common bus to limit fault current to 10,000 amps. Each individual meter may be connected either cold sequence or hot sequence with the disconnecting means (switch or circuit breaker) located adjacent to the meter socket. A fault current-limiting circuit breaker may be utilized for the main disconnect if Company approved in accordance with Exception 1 above.

Exception 3: Single-phase commercial installations up to 320 amps are permitted to be hot sequenced provided all three of the following conditions are met:

- 1. Only one meter is served by the overhead service drop or underground service lateral.*
- 2. The available fault current is below 10,000 amps. The Company may require a fault-current analysis report be provided to verify if an installation meets this requirement.*
- 3. The service voltage is 240 volts or less.*

Note: Three-phase meters do not qualify for this exception except as specified in Section 4.18.1 HOT SEQUENCE METERING, Residential.

A cold sequence disconnect shall be furnished, owned, installed, and maintained by the customer.

The cold sequence disconnect shall be installed on the same wall directly ahead of and within twenty-four (24) inches of the meter.

The cold sequence disconnect shall contain provisions for a Company wire seal for the cover and a Company padlock in the operating handle lock-off position. Wire seals will be used by the Company secure the enclosure from unauthorized entry and will allow the customer emergency access to reset breaker or to replace fuses. A Company padlock will only be used to lock disconnects in the off position for services that are shutoff.

The cold sequence disconnect shall not be operated by the customer except for emergency conditions. For seasonal loads or service discontinuance, the cold sequence disconnect shall not be operated in an off position in lieu of a service disconnection by the Company. Customer requiring a service to be discontinued shall contact the Builders Call Line.

Note: All, Company-owned meters shall stay energized up to the line-side terminals of the meter socket, in order to obtain information concerning connected load, to measure or test service, to read meters, or for other purposes incidental to the supplying of electric service.

The amp rating of the cold sequence disconnect shall not exceed the amp rating of the meter sockets and shall be installed in accordance with 2017 *National Electrical Code*[®] Article 230, or as may be amended.

Tables VI through VIII in Section 5 can be used to determine if the available fault current at a single-phase electric meter socket is less than 10,000 amps based on a specific transformer size and service conductor size and length.

4.18 HOT SEQUENCE METERING

4.18.1 Residential

Residential self-contained meter installations, both single-phase and three-phase, shall be hot sequence metering.

In Colorado only, if the fault current does exceed 10,000 amps at the electric meter, instrument transformer (CT) type metering shall be utilized.

Exception 1: A fault current-limiting circuit breaker shall be utilized in lieu of a fusible load-break safety or pullout switch if pre-approved by the Company's Electric Meter Engineering Department. The request shall be submitted in writing through the written exception process and include a fault current analysis report by a registered professional engineer. All calculations shall be based upon the worst-case transformer percent resistance, percent reactance, and percent impedance values shown in Section 5, Tables I through V.

Note: Exception will not be granted for the use of any type of fault current-limiting fuses ahead of the meter for single family residential applications.

Exception 2: Multiple residential tenant meter sockets are permitted to have a single fusible current-limiting main disconnect ahead of the common bus to limit fault current to 10,000 amps. Single-phase or three-phase commercial house power meters (e.g. common lighting, emergency lighting, or laundry facilities) may be protected by the current-limiting main disconnect that serves the residential meter stack. Common lighting, emergency lighting, or laundry facility meters not fed from a protected meter stack shall be cold sequenced. A fault current-limiting circuit breaker may be utilized for the main disconnect if Company-approved in accordance with Exception 1 above.

4.18.2 Commercial and Industrial

Refer to Section 4.17 **COLD SEQUENCE METERING** for jurisdictional requirements for commercial and industrial self-contained metering.

Effective Date November 15, 2018

Hot Sequence is the required installation method for commercial and industrial instrument transformer type (CT) metering.

Note: Cold sequence disconnects are not allowed ahead of the CT cabinet, unless required by local Public Authority having jurisdiction, or in multi-unit instances where a single main disconnect may be ahead of a CT compartment.

This Page Intentionally Left Blank

Section 5

5. TRANSFORMERS

Necessary transformers will be installed and maintained by the Company in accordance with its established Rate Schedules, Electric Service Connection Policy, and Line Extension Policy.

The Company will not furnish transformers unless they are of standard size and voltage as established by the Company for the locality where the service is rendered. The customer shall notify the Company in advance of any change in the customer's load requirements that may affect the installed transformer capacity.

If the customer's power requirement, within six months after the installation of transformers, proves to be more than the installed transformer capacity, the Company may make an increase in the installed transformer capacity and the customer will be required to pay to the Company the cost of making the change.

5.1 GROUNDING

All service systems that operate below 1000 volts contain a grounded neutral or a grounded phase conductor used as a circuit conductor in the system. The grounded neutral or grounded phase conductor is grounded at the supply transformer and will be run from the transformer bank to the meter socket and to each service disconnection means in accordance with 2017 *National Electrical Code*[®] Article 250.24(B), or as may be amended.

Customer requiring an ungrounded service for operation of a ground detection system, or for other operations permitted by the *National Electrical Code*[®], shall submit an exception request detailing the special circumstances necessitating the request. In addition, the customer shall state in the exception request that he is aware of and accepts the increased risk to personal safety associated with an ungrounded service. When supplying an ungrounded service results in an additional cost to the Company, the additional cost may be passed on to the customer.

5.2 SPECIAL RULES

When a customer furnishes transformers or other equipment, in accordance with the applicable Company Rate Schedule, Electric Service Connection Policy, and Line Extension Policy, the Company accepts no responsibility for maintaining or replacing the customer's transformers or other equipment if damaged or destroyed.

Company Rate Schedules for primary metering installations require that the customer provide and own all equipment beyond the point of delivery. In unusual cases, the Company may rent transformers, if available, to the customer in accordance with the Company's Rules and Regulations.

The customer shall provide a minimum of ten (10) feet level clearance on the door side(s) of pad-mounted transformers for hot-stick operation and ten (10) feet level clearance on the door side(s) of pad-mounted primary metering cabinets for instrument transformer maintenance. Transformers shall not be located under any overhang (roof, balcony, stairs, etc.). Clearance requirements are shown in the Illustrations Section, **Drawings CR-30, CR-40, CR-50, CR-60, CR-90, and CR-100.**

5.3 FAULT CURRENT

It is the intent of the Company to address the customer's need for information concerning fault current and transformer protective device requirements pertaining to new construction, rewire, or additional load. Refer to 2017 *National Electrical Code*[®] Article 110.9 Interrupting Rating and Article 110.16 Arc-Flash Hazard Warning, or as may be amended.

Tables IA through V in this Section show the available RMS symmetrical fault currents that may be expected at the secondary terminals of distribution transformers. Each fault current value listed in the tables is based on the lowest percent impedance transformer that might be set initially or as a replacement. No primary source or secondary line impedance has been included since it generally relatively small, may change, and cannot be accurately forecasted.

Note: Because an overloaded transformer is typically replaced by the next larger size transformer, and an under-loaded transformer may be replaced by the next smaller size transformer, the customer is encouraged to use this range of transformers to perform their studies and select equipment such as current-limiting fuses, breakers and switchgear bus bar bracing.

Table VI through VIII in this Section can be used to determine if the available fault current at a single-phase electric meter socket is less than 10,000 amperes based on specific transformer size and service conductor size and length, which may allow a single-phase commercial installation to be hot sequenced. Refer to Section 4.17, COLD SEQUENCE METERING Exception 3 for the exact requirements.

Due to the variability of the transformer and electric distribution system characteristics these tables are to be used as a general guideline and shall not be used as a design tool to replace engineering that may be required by the Code Authorities having jurisdiction. Customers or contractors requiring specific fault current calculations should consult a registered professional engineer of their choice.

Two types of faults are possible on a single-phase transformer having a 120/240V secondary: 1) across terminals having 120V between them, and 2) across terminals having 240V between them. While the 120V fault is higher at the transformer terminals, it attenuates more rapidly as the effect of cable impedance is added. Because of this affect, the 240V fault is often higher at the meter or CT enclosure. The following tables have been developed to aid in determining the available fault current levels at the electric meter. In addition, the tables can be used to determine the number of feet of a given size conductor between the transformer and the terminals of the meter needed to limit the available fault current to 10,000 amps.

Note 1: All residential installations served from a single-phase pad-mounted transformer shall use the calculations based on the installation of a 50kVA minimum transformer.

Note 2: All temporary construction meter installations may use the actual transformer size.

5.4 ARC FLASH

It is the intent of the Company to address a customer's need for information concerning arc flash data requires as follows:

For Secondary Voltage Services the Company will provide, upon request from the customer:

1. Transformer size, primary voltage, secondary voltage, and typical percent impedance
2. Transformer primary fuse information size and type.
3. Maximum available secondary symmetrical three-phase fault current, from Tables IA through V in this Section.

For Primary Voltage Services (excluding network services)⁴ the Company will provide, upon request from the customer:

1. Calculated symmetrical bolted three-phase fault current, bolted single-line ground fault current and X/R ratio at the service point.
2. The upstream protective device information nearest the service point. This information will include the device model, rating, and applicable settings.

Fault current calculations are based upon the distribution system configuration at the time of the calculations. The Company does not provide minimum fault current information or associated protective device clearing times.

It is understood that this data is to be used for arc flash calculations. Parties using this data must understand that it may change due to various circumstances. The Company will not notify the customer when such changes occur.

Tables IA through V in this Section are only intended to provide the basic information necessary for secondary service customers to make their own internal system fault current and arc flash calculations. Primary service customers will still need to consult with a Company Area Engineer, to obtain fault current and protective device information for their service locations.

It is highly recommended when customers are performing maintenance work on or near exposed equipment or circuit parts that their electrical system be de-energized whenever possible.

⁴ For network service information, please contact the local area engineer.

TABLE IA

SINGLE-PHASE OVERHEAD TRANSFORMERS																				
SINGLE-PHASE FAULT CURRENT IN RMS AMPS SYMMETRICAL EXPECTED AT THE SECONDARY TERMINALS OF THE TRANSFORMER																				
									Transformer Protective Device											
									NSP				PSCO			SPS				
TR	TR	TR	TR	Fault Current	TR	TR	TR	Fault Current	4kV	15 kV	25 kV	35 kV		4 kV	15 kV	25 kV	4 kV	15 kV	25 kV	35 kV
kVA	%R	%X	%Z	120 V Secondary	%R	%X	%Z	240 V Secondary				Link	Current Limiter							
10	1.5	1.2	1.9	4,300	1	1	1.4	2,900	10T	3T	2T	2K	12 Amp	10K	1.4*	0.7*	5.5X	2X	1.25X	0.75X
15	1.5	1.2	1.9	6,500	1	1	1.4	4,400	12T	3T	2T	2K	12 Amp	15K	2.1*	1.0*	15QA	2.5X	1.5X	1.25X
25	1.5	1.2	1.9	10,900	1	1	1.4	7,400	15T	6T	3T	3K	12 Amp	25K	10K	2.1*	20QA	5.5X	2.5X	1.5X
50	1.5	1.2	1.9	21,700	1	1	1.4	14,800	30T	10T	6T	6K	12 Amp	40K	15K	10K	40QA	15QA	5.5X	4X
75	1.5	1.2	1.9	32,600	1	1	1.4	22,200	50T	12T	8T	8K	12 Amp	65K	25K	15K	50QA	20QA	7X	5.5X
100	1.5	1.2	1.9	43,400	1	1	1.4	29,600	65T	15T	10T	10K	12 Amp	100K	25K	15K	75QA	25QA	15QA	7X
150	1.5	1.2	1.9	65,100	1	1	1.4	44,400	--	--	--	--	--	140K	40K	25K	125QA	40QA	20QA	15QA
167	1.5	1.2	1.9	72,500	1	1	1.4	49,400	100T	25T	15T	20K	25 Amp	140K	65K	25K	125QA	40QA	20QA	15QA

* Chance Slo-Fast speed fuses

TABLE IB

SINGLE-PHASE PAD MOUNTED TRANSFORMERS								
SINGLE-PHASE FAULT CURRENT IN RMS AMPS SYMMETRICAL EXPECTED AT THE SECONDARY TERMINALS OF THE TRANSFORMER. ALL FAULT CURRENTS ARE BASED ON 1% R AND 1%X FOR THE TRANSFORMER IMPEDANCE.								
TR	TR	TR	TR	Transformer Protective Device (Dual Sensing Bay-O-Net Fuses for NSP, PSCo, and SPS)				
kVA	%R	%X	%Z	240 V Secondary				
25	1	1	1.4	7,400	4 kV	15 kV	25 kV	35 kV
50	1	1	1.4	14,800	25	8	3	3
100	1	1	1.4	29,600	50	15	8	8
150	1	1	1.4	44,400	65	25	15	8
167	1	1	1.4	49,400	100	50	25	15

TABLE II

THREE-PHASE PAD MOUNTED TRANSFORMERS									
THREE-PHASE FAULT CURRENT IN RMS AMPS SYMMETRICAL EXPECTED AT THE SECONDARY TERMINALS OF THE TRANSFORMER.									
TR	TR	TR	TR	Fault Current	Fault Current	Transformer Protective Device (Dual Sensing Bay-O-Net Fuses for NSP, PSCo, and SPS)			
kVA	%R	%X	%Z	120/208 V Secondary	277/480 V Secondary	4 kV	15 kV	25 kV	35 kV
75	1	1.25	1.6	13,000	5,600	25	8	3	3
150	1	1.25	1.6	26,000	11,200	50	15	8	8
300	1	1.25	1.6	52,000	22,500	65	25	15	8
500	1	1.5	1.8	77,100	33,400	140	50	20	15
750	1	5.22	5.32	39,100	16,900	140	65	50	25
1000	0.86	5.25	5.32	52,100	22,600	--	65	50	25
1500	0.86	5.25	5.32	78,200	33,900	--	140	65	50
2000	0.86	5.25	5.32	--	45,200	--	125	100	65
2500	0.65	5.28	5.32	--	56,500	--	125	125	100

TABLE III

THREE-PHASE OVERHEAD WYE CONNECTED TRANSFORMER BANKS										
THREE-PHASE FAULT CURRENT IN RMS AMPS SYMMETRICAL EXPEVTE AT THE SECONDARY TERMINALS OF THE TRANSFORMER. ALL FAULT CURRENTS ARE BASED ON 1%R AND 1%X FOR THE TRANSFORMER IMPEDANCE.										
						NSP - Transformer Protective Device				
TR	TR	TR	TR	Fault Current	Fault Current	4 kV	15 kV	25 kV	35 kV	
kVA	%R	%X	%Z	120/208 V Secondary	277/480 V Secondary				Link	Current Limiter
45	1	1	1.4	8,900	3,800	12T	3T	2T	2K	12 Amp
75	1	1	1.4	14,800	6,400	15T	6T	3T	3K	12 Amp
150	1	1	1.4	29,700	12,800	30T	10T	6T	6K	12 Amp
300	1	1	1.4	59,400	25,700	65T	15T	10T	10K	12 Amp
500	1	1	1.4	99,100	42,900	100T	25T	15T	20K	25 Amp
						PSCo - Transformer Protective Device				
TR	TR	TR	TR	Fault Current	Fault Current	4 kV	15 kV	25 kV		
kVA	%R	%X	%Z	120/208 V Secondary	277/480 V Secondary					
45	1	1	1.4	8,900	3,800	15K	2.1*	1.0*		
75	1	1	1.4	14,800	6,400	25K	10K	2.1*		
150	1	1	1.4	29,700	12,800	40K	15K	10K		
300	1	1	1.4	59,400	25,700	100K	25K	15K		
500	1	1	1.4	99,100	42,900	140K	65K	25K		
						SPS - Transformer Protective Device				
TR	TR	TR	TR	Fault Current	Current	4 kV	15 kV	25 kV	35 kV	
kVA	%R	%X	%Z	120/208 V Secondary	277/480 V Secondary					
45	1	1	1.4	8,900	3,800	15QA	2.5X	1.5X	1.25X	
75	1	1	1.4	14,800	6,400	20QA	5.5X	2.5X	1.5X	
150	1	1	1.4	29,700	12,800	40QA	15QA	5.5X	4X	
300	1	1	1.4	59,400	25,700	75QA	25QA	15QA	7X	
500	1	1	1.4	99,100	42,900	125QA	40QA	20QA	15QA	

* Chance Slo-fast speed fuses

TABLE IV

THREE-PHASE OVERHEAD OPEN DELTA SECONDARY TRANSFORMER BANKS

THREE-PHASE FAULT CURRENT IN RMA AMPS SYMMETRICAL EXPECTED AT THE SECONDARY TERMINALS OF THE TRANSFORMER. DELTA SECONDARY TRANSFORMER BANK EQUIVALENT IMPEDANCE VALUES: MODEL AS NEEDED USING THE SINGLE-PHASE OVERHEAD TRANSFORMER IMPEDANCE VALUES SHOWN IN TABLE IA.

				Transformer Protective Device											
				NSP					PSCo			SPS			
TR kVA		Fault Current		4 kV	15 kV	25 kV	35 kV		4 kV	15 kV	25 kV	4 kV	15 kV	25 kV	35 kV
Power	Lighting	120/240 V Secondary	240/480 V Secondary				Link	Current Limiter							
10	10	6,144	3,072	10T	3T	2T	2K	12 Amp	10K	1.4*	0.7*	5.5X	2X	1.25X	.75X
10	25	9,935	4,968	15T	6T	3T	3K	12 Amp	25K	10K	2.1*	20QA	5.5X	2.5X	1.5X
10	50	16,944	8,472	30T	10T	6T	6K	12 Amp	40K	15K	10K	40QA	15QA	5.5X	4X
10	75	24,166	12,083	50T	12T	8T	8K	12 Amp	65K	25K	15K	50QA	20QA	7X	5.5X
10	100	31,455	15,728	65T	15T	10T	10K	12 Amp	100K	25K	15K	75QA	25QA	15QA	7X
10	167	51,098	25,549	100T	25T	15T	20K	12 Amp	140K	65K	25K	125QA	40QA	20QA	15QA
25	25	15,362	7,681	15T	6T	3T	3K	12 Amp	25K	10K	2.1*	20QA	5.5X	2.5X	1.5X
25	50	21,514	10,757	30T	10T	6T	6K	12 Amp	40K	15K	10K	40QA	15QA	5.5X	4X
25	75	28,253	14,127	50T	12T	8T	8K	12 Amp	65K	25K	15K	50QA	20QA	7X	5.5X
25	100	35,244	17,622	65T	15T	10T	10K	12 Amp	100K	25K	15K	75QA	25QA	15QA	7X
25	167	54,468	27,234	100T	25T	15T	20K	25 Amp	140K	65K	25K	125QA	40QA	20QA	15QA
50	50	30,724	15,362	30T	10T	6T	6K	12 Amp	40K	15K	10K	40QA	15QA	5.5X	4X
50	75	36,653	18,327	50T	12T	8T	8K	12 Amp	65K	25K	15K	50QA	20QA	7X	5.5X
50	100	43,028	21,514	65T	15T	10T	10K	12 Amp	100K	25K	15K	75QA	25QA	15QA	7X
50	167	61,220	30,610	100T	25T	15T	20K	25 Amp	140K	65K	25K	125QA	40QA	20QA	15QA
75	75	46,086	23,043	50T	12T	8T	8K	12 Amp	65K	25K	15K	50QA	20QA	7X	5.5X
75	100	51,923	25,962	65T	15T	10T	10K	12 Amp	100K	25K	15K	75QA	25QA	15QA	7X
75	167	69,024	34,512	65T	15T	10T	10K	12 Amp	100K	25K	15K	125QA	40QA	20QA	15QA
100	100	61,448	30,724	65T	15T	10T	10K	12 Amp	100K	25K	15K	75QA	25QA	15QA	7X
100	167	77,563	38,782	100T	25T	15T	20K	25 Amp	140K	65K	25K	125QA	40QA	20QA	15QA
167	167	102,618	51,309	100T	25T	15T	20K	25 Amp	140K	65K	25K	125QA	40QA	20QA	15QA

* Chance Slo-fast speed fuses

TABLE V

THREE-PHASE OVERHEAD CLOSED DELTA SECONDARY TRANSFORMER BANKS

THREE-PHASE FAULT CURRENT IN RMS AMPS SYMMETRICAL EXPECTED AT THE SECONDARY TERMINALS OF THE TRANSFORMER. DELTA SECONDARY TRANSFORMER BANK EQUIVALENT IMPEDANCE VALUES: MODEL AS NEEDED USING THE SINGLE-PHASE OVERHEAD TRANSFORMER IMPEDANCE VALUES SHOWN IN TABLE IA.

TR kVA			Fault Current		Transformer Protective Device											
					NSP					PSCo			SPS			
Power		Lighting	120/240 V Secondary	240/480 V Secondary	4 kV	15 kV	25 kV	35 kV		4 kV	15 kV	25 kV	4 kV	15 kV	25 kV	35 kV
								Link	Current Limiter							
10	10	10	6,782	3,391	10T	3T	2T	2K	12 Amp	10K	1.4*	0.7*	5.5X	2X	1.25X	0.75X
10	10	25	12,757	6,379	15T	6T	3T	3K	12 Amp	25K	10K	2.1*	20QA	5.5X	2.5X	1.5X
10	10	50	25,515	12,758	30T	10T	6T	6K	12 Amp	40K	15K	10K	40QA	15QA	5.5X	4X
10	10	100	51,031	25,516	65T	15T	10T	10K	12 Amp	100K	25K	15K	75QA	25QA	15QA	7X
10	10	167	85,221	42,611	100T	25T	15T	20K	12 Amp	140K	65K	25K	125QA	40QA	20QA	15QA
25	25	25	16,956	8,478	15T	6T	3T	3K	12 Amp	25K	10K	2.1*	20QA	5.5X	2.5X	1.5X
25	25	50	25,515	12,758	30T	10T	6T	6K	12 Amp	40K	15K	10K	40QA	15QA	5.5X	4X
25	25	100	51,031	25,516	65T	15T	10T	10K	12 Amp	100K	25K	15K	75QA	25QA	15QA	7X
25	25	167	85,221	42,611	100T	25T	15T	20K	25 Amp	140K	65K	25K	125QA	40QA	20QA	15QA
50	50	50	33,913	16,957	30T	10T	6T	6K	12 Amp	40K	15K	10K	40QA	15QA	5.5X	4X
50	50	100	51,031	25,516	65T	15T	10T	10K	12 Amp	100K	25K	15K	75QA	25QA	15QA	7X
50	50	167	85,221	42,611	100T	25T	15T	20K	25 Amp	140K	65K	25K	125QA	40QA	20QA	15QA
100	100	100	67,826	33,913	65T	15T	10T	10K	12 Amp	100K	25K	15K	75QA	25QA	15QA	7X
100	100	167	85,221	42,611	100T	25T	15T	20K	25 Amp	140K	65K	25K	125QA	40QA	20QA	15QA
167	167	167	113,270	56,635	100T	25T	15T	20K	25 Amp	140K	65K	25K	125QA	40QA	20QA	15QA

* Chance Slo-fast speed fuses

TABLE VI

Minimum length, in feet, of low voltage conductor (secondary plus service drop) needed to limit the available 120 or 240 volt fault current from a single-phase transformer secondary to less than 10,000 amps.

Underground Conductor:

TRANSFORMER	120/240 VOLT SINGLE-PHASE ALUMINUM CONDUCTOR SIZE					
SIZE (kVA)	#4	#1	1/0	2/0	4/0	350
25	5'	5'	5'	5'	5'	10'
50	15'	20'	25'	35'	45'	65'
100	20'	40'	50'	60'	90'	135'

Overhead Conductor:

TRANSFORMER	120/240 VOLT SINGLE-PHASE ALUMINUM CONDUCTOR SIZE						
SIZE (kVA)	#4	#1	1/0	2/0	4/0	350	500
25	5'	5'	5'	5'	10'	10'	15'
50	15'	20'	30'	35'	50'	70'	90'
75	20'	30'	45'	55'	80'	120'	150'
100	25'	35'	50'	65'	95'	140'	185'

TABLE VII

Minimum length, in feet, of low voltage conductor (secondary plus service drop) needed to limit the available 120 or 240 volt fault current from one unit of a three-phase delta transformer secondary to less than 10,000 amps.

Overhead Conductor:

Note: The transformer size is the largest single-phase unit of the three-phase bank.

TRANSFORMER	120/240 VOLT SINGLE-PHASE ALUMINUM CONDUCTOR SIZE						
SIZE (kVA)	#4	#1	1/0	2/0	4/0	350	500
25	5'	10'	15'	15'	25'	25'	30'
50	20'	30'	45'	55'	80'	120'	155'
100	25'	40'	60'	75'	110'	165'	215'

TABLE VIII

Minimum length, in feet, of low voltage conductor (secondary plus service drop) needed to limit the available single-phase 120 or 208 volt fault current from one or two units of a three-phase wye transformer secondary to less than 10,000 amps.

Underground Conductor:

Note: The transformer size is the three-phase rating.

TRANSFORMER	120/208 VOLT SINGLE-PHASE ALUMINUM CONDUCTOR SIZE					
SIZE (kVA)	#4	#1	1/0	2/0	4/0	350
150	20'	35'	40'	50'	70'	110'
300	20'	40'	50'	60'	95'	140'

Overhead Conductor:

Note: The transformer size is the largest single-phase unit of an overhead three-phase bank.

TRANSFORMER	120/208 VOLT SINGLE-PHASE ALUMINUM CONDUCTOR SIZE				
SIZE (kVA)	#4	#1	1/0	2/0	4/0
25	10'	15'	20'	20'	30'
50	20'	30'	45'	50'	80'
100	25'	35'	55'	65'	100'

Section 6

6. UTILIZATION EQUIPMENT

All electric wiring, ducts, cables and apparatus, including protective equipment, necessary for utilization of electric service on the customer's side of the point of delivery, shall be furnished, installed, and maintained by the customer. Such equipment should be selected to provide efficient use of energy and good voltage regulation. The customer shall not use any equipment or device that will adversely affect the Company's service to the customer or to other customers. The customer's equipment shall be suitable for the service supplied and shall be installed and maintained in good and safe condition by the customer in accordance with the rules and requirements of the *National Electrical Code*[®], the local Public Authority, and the Company.

6.1 THREE PHASE VOLTAGE UNBALANCE

$$\text{Percent Voltage Unbalance} = 100 \times \frac{\text{Maximum Voltage Deviation from Average Voltage}}{\text{Average Voltage}}$$

Example: With voltages of 220, 216, and 209, the average is 215, the maximum deviation from the

average is 6 and the Percentage Unbalance = $100 \times \frac{6}{215} = 2.79\%$

Note: These calculations must use phase-to-phase voltages as shown in the example. Phase-to-neutral voltages may give inaccurate results.

The Company's goal is to limit the maximum steady-state voltage unbalance to 3 percent, in accordance with ANSI C84.1. Voltage unbalance will be measured at the customer's service entrance with all loads disconnected.

The customer's load may affect voltage measurements because of three-phase load and power factor unbalance. Because it is not always practical to require the customer to disconnect all load, the Company may take measurements by measuring individual phase loads and power factors and calculating their effect on measurements taken without disconnecting the load.

When a customer's three-phase service voltage is found to have an unbalance greater than 3 percent, the Company will act to reduce the unbalance and bring it within these limits within a reasonable length of time.

6.2 HARMONICS

There is a growing proportion of harmonic producing, non-linear loads on distribution systems. Excessive harmonic distortion on the distribution system can have adverse effects on both utility and customer equipment. To limit the harmonic currents and resulting harmonic voltages created by non-linear loads, the guidelines included in IEEE Std 519-1992 "IEEE Recommended Practices and Requirements for Harmonic Control in Electric Power Systems" shall be followed. The following table gives the allowable limits of electric current distortion at the point of delivery.

**Current Distortion Limits for General Distribution Systems
(120 through 69,000 V)**

MAXIMUM HARMONIC CURRENT DISTORTION IN PERCENT OF I_L						
Individual Harmonic Order (Odd Harmonics)						
I _{sc} /I _L	h < 11	11 ≤ h < 17	17 ≤ h < 23	23 ≤ h < 35	35 ≤ h	TDD
< 20	4.0	2.0	1.5	0.6	0.3	5.0
20 < 50	7.0	3.5	2.5	1.0	0.5	8.0
50 < 100	10.0	4.5	4.0	1.5	0.7	12.0
100 < 1000	12.0	5.5	5.0	2.0	1.0	15.0
> 1000	15.0	7.0	6.0	2.5	1.4	20.0

- “I_{sc}” is the short circuit current (aka fault current) available from the Company at the Point of Delivery.
- “I_L” is the maximum demand load current of the customer (fundamental frequency component). I_L may be calculated as the average monthly maximum demand interval current for the preceding twelve months.
- “h” is the order of the harmonic.
- Even harmonics are limited to 25% of the odd harmonic limits listed in the table above.
- The current distortion limits apply to the demand interval in use, either 15 or 30 minutes.
- Current distortions that result in a direct current offset (e.g. half-wave converters) are not allowed.
- For short period such as during start-up or unusual conditions, the limits may be exceeded by 50%.
- All power generation equipment shall comply with the I_{sc}/I_L < 20 distortion limits regardless of the actual I_{sc}/I_L value.
- “TDD” is the total harmonic distortion in percent where: $TDD = \frac{(I_2^2 + I_3^2 + I_4^2 + \dots + I_h^2)^{1/2}}{I_L} \times 100$
- Individual harmonic current distortion is: $\% I_h = \frac{I_h}{I_L} \times 100$

THD, whether voltage or current, is always an instantaneous quantity given as a percent of the fundamental (60 Hz) voltage or current. The total harmonic distortion (THD) rating of equipment is the harmonic current distortion when the equipment is operating at rated load. When a power quality meter used in a PQ study indicates a current THD, it is stating the harmonic current as a percent of the fundamental current at a given instant in time.

TDD is the average distortion over a demand interval. To determine the average maximum demand interval value, the average of the maximum demand interval for each of the preceding twelve months is determined and then average (I_L). The harmonic current limit is in percent of this average fundamental load current over a demand interval. The current limit does not apply to THD. The objective of the limits provided in the above table is to ensure the composite effect, on the supply system, of all harmonic current contributions are held to a level such that the resulting supply voltage harmonic distortion is under the desired threshold.

For example: If the 12 month average of the monthly maximum demands currents for a customer equals 150 ampere (I_L) and the available fault (I_{SC}) is 5000 A, then the ratio is 33, the total demand distortion (TDD) limit is 8%, and the harmonic current limit is 12 A ($0.08 \times 150 A = 12 A$). The harmonic current content of the customer's load should normally be under the 12 A level. On rare occasion, the harmonic current can briefly be up to 18A ($12 A \times 1.5 = 18 A$) and still comply with the 8% current distortion limit used in this example.

6.3 POWER FACTOR ADJUSTMENT

Requirements for power factor adjustment vary depending on the Company's established Rates, Rules and Regulations. Contact the Company for specific information.

Low power factor has an adverse effect, not only on the Company's electric systems, but also on the customer's electric system. Improvement in the latter alone often warrants the customer's installation of high power-factor equipment.

6.4 MOTORS

Appliances and apparatus should be equipped with motors which will provide the customer with satisfactory operation of the appliance and at the same time avoid interference with service to other customers. Motors may cause voltage disturbances resulting in flickering lights, television interference, and other objectionable conditions.

6.4.1 Motor Identification

All motors connected to the Company's lines shall bear a manufacture's nameplate indicating horsepower, continuous or intermittent duty, speed, voltage and current ratings. When a motor is rewound to produce a change in the original design, a new nameplate shall be attached indicating the new characteristics.

6.4.2 Voltage

All new motor installations shall be designed to operate on the type of service provided by the Company. The Company's Area Engineering Department will advise the customer as to the type of service available at the locations where the motor is to be used. Inquiry should be made before purchasing or installing the motor.

6.4.3 Allowable Starting Current

The starting current characteristics of an electric motor are of primary importance to the voltage disturbance the motor will create on the Company's system. The starting kVA/HP for large motors generally does not exceed six (6) times the full load kVA/HP. The resulting voltage drop to the system may be acceptable under certain conditions. Starting current can be limited by the motor design or by use of auxiliary control equipment which reduces the voltage drop at the motor terminals during the starting interval. The auxiliary control equipment shall comply with the limitations provided under HARMONICS in this Section. Automatically controlled motors shall be adjusted to not exceed the starting limitations provided by the Company. Reduced voltage starting equipment that chops the voltage waveform may not meet these requirements (i.e. SCRs, thyristors, etc.). The voltage flicker that is produced by starting automatically controlled motors shall meet the limitations specified under MOTORS, Voltage Flicker in the Section.

Depending of the service size, the starting current of residential central air conditioners can cause objectionable voltage flicker. The magnitude of the voltage flicker increases with the size of the air conditioner. Contact the Company Area Engineering Department when assistance is required to determine actual field conditions and limitations.

6.4.4 Voltage Flicker

The Company uses IEEE Standards 1453 - 2015 as a guideline for the level of allowable flicker. Customers are not allowed to start or operate any load on the Company's system that produces unacceptable levels of flicker which affect other customers. Customers are responsible for correcting unacceptable flicker problems in a timely manner when notified by the Company.

A customer load or source that produces flicker greater than the "IEEE 1453 Flicker Curve" may be unacceptable and further evaluation under the full IEEE 1453 methodology may be required. The full methodology applies fluctuation specific adjustment factors and may indicate the Customer's equipment is acceptable. Field measurement of flicker should use the IEEE 1453 Flicker Meter methodology. Most power quality meters have this built in. Customer energy sources, like wind and photovoltaic, will also be evaluated under the IEEE Standard 1547 – 2018, Article 7.2 requirements.

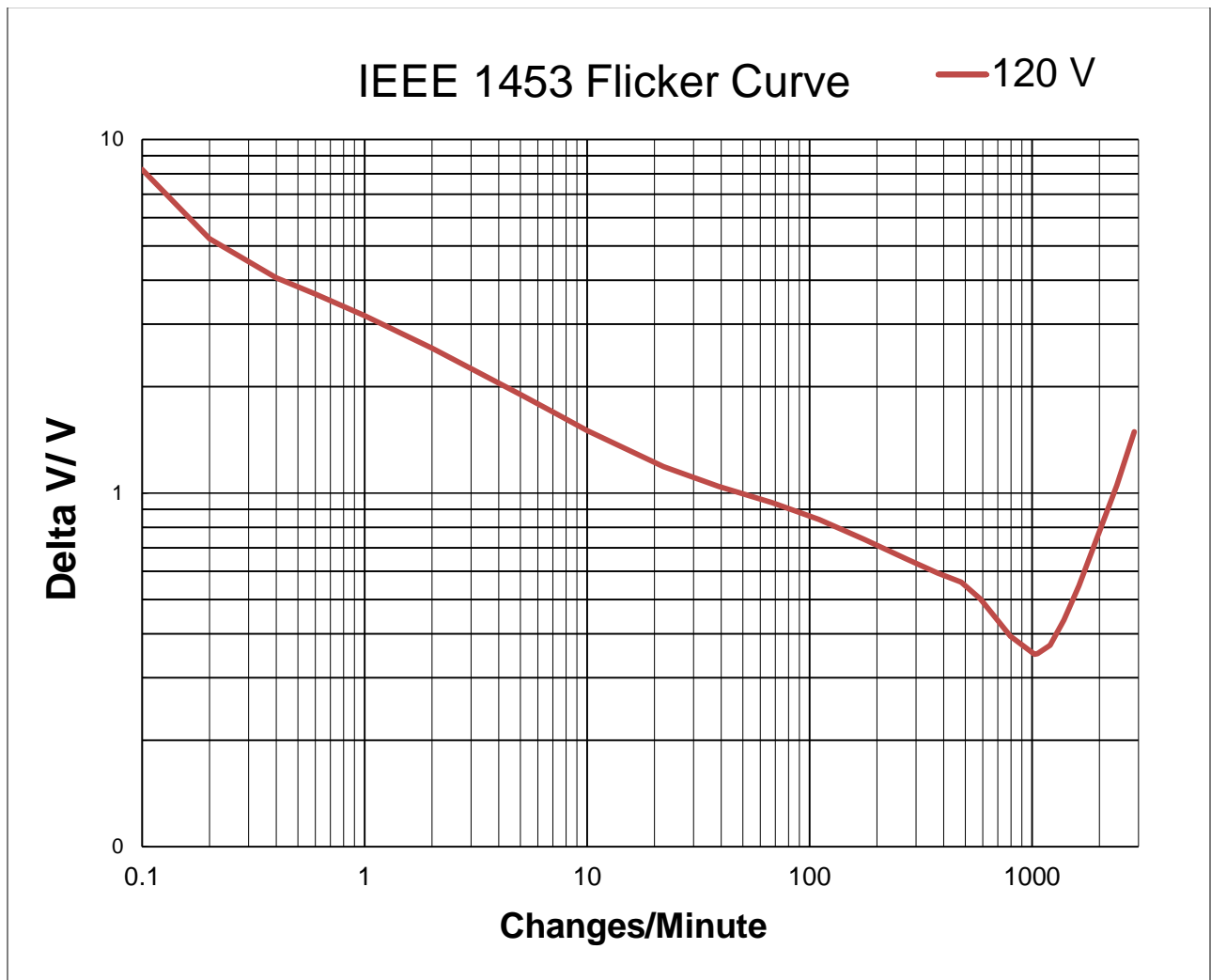

1453 Graph Application Notes:

1. IEEE 141 uses dips per time period. IEEE 1453 uses changes per time period. E.g. 1 dip = 2 changes.
2. Changes, i.e. fluctuations, can be a dip or surge, from a load or energy source.
3. Both curves are valid only when applied to ongoing periodic fluctuations.
4. IEEE 141 does not apply to step-changes, such as motor starts, or other non-periodic events.
5. IEEE 1453 uses Rapid Voltage Change limits for step-changes, see Limit Table.
6. IEEE 1453 has Shape Factor curves to adjust the base graph for other fluctuation shapes.

Rapid Voltage Change Limit Table

NUMBER OF CHANGES, N	$\Delta V/V_r$ (%)	
	MV	HV-EHV
$N \leq 4$ per day	5-6	3-5
$N \leq 2$ per hour	4	3
$2 < N \leq 10$ per hour	3	2.5

6.4.5 Horsepower Rating

Motors rated for 5 horsepower or smaller shall be single-phase unless an established three-phase service exists. Single-phase motors larger than 5 horsepower will not be permitted on services supplied on a residential rate schedule without permission of the Company. Single-phase motors larger than 5 horsepower may be permitted on services supplied on a non-residential rate schedule with Company approval. Larger motors may require starting compensation to limit voltage variation on the system – consult the Company if there is any doubt. The Company will not be held responsible for, nor continue service to, motors with unacceptable starting characteristics.

6.4.6 Grounding

The frame of all motors and starters shall be grounded in accordance with the *National Electrical Code*®.

6.4.7 Protection of Customer Owned Equipment

Whenever the inherent design of a motor or the characteristics of the load which it serves are such that either automatic reclosing of the electric circuit after a power interruption or sustained low voltage would damage either the motor or the driven equipment, the customer should provide adequate protection to prevent such damage. Starting compensators, auto starters, or equivalent apparatus included in each motor installation should be equipped with under-voltage protection to return the starting apparatus to the “off” position upon failure of the supply circuit.

Three-phase motors which would cause damage to the driven equipment due to a reversal of motor rotation should be equipped with reverse-phase relays to disconnect the motor from the line if it should receive single-phase or reverse-phase power. In addition, mechanical devices should be installed to prevent damage due to travel of the driven mechanism in the wrong direction. The Company assumes no liability for damage resulting from single-phase or reverse-phase operation of three-phase equipment.

Three over-current protective devices should be provided for three-phase motors.

6.5 NON-LINEAR LOADS

It is necessary that welders, x-ray machines, variable-speed motors, and any other large non-linear loads, permanent or temporary, be installed and operated in such a manner that they will not impair service to other customers.

The limited use of single-phase transformer type welders is permitted when adequate transformer and distribution capacity is available, provided the maximum welder input cannot at any time exceed 60 amperes at 240 volts or 30 amperes at 120 volts. The customer shall consult the Company prior to the purchase or installation of welders exceeding these limits. Service for motor-generator and synchronous converter type welders will be governed by the rules and regulations for motors.

6.6 WATER PIPE THAWING

Because of the danger of damage to its equipment and impairment of its service, the Company does not permit direct line connection to water pipes for thawing purposes. Customer or contractors desiring service for water pipe thawing apparatus should consult the Company.

6.7 SPECIAL APPARATUS

The customer shall consult with the Company before any special apparatus or any apparatus requiring extremely close voltage regulation is connected. It is necessary that electrical equipment be installed and operated in a manner that will not impair service to other customers. The use of welding machines, x-ray machines, elevators, or other equipment having fluctuating or intermittent load characteristics, or having an abnormal effect on voltage, may require furnishing service through isolated transformers and separate service drops or excess capacity facilities in order to protect the quality of service to the customer or to other customers. The Company reserves the right to charge the customer the full cost of facilities necessary to provide any special service required by such equipment and to prevent any impairment in service to other customers.

6.8 LOAD BALANCE

No single-phase loads in excess of 50 kVA on a 4.16 kV system or 100 kVA on higher voltage systems will be served except by special arrangement with the Company. Lower limits may apply in certain service areas. The customer's wiring on three-wire, single-phase installations shall be so arranged that the connected load from one phase to neutral shall not exceed 60 percent of the customer's total connected load. The use of single-phase loads on three-phase services shall not unbalance the current per phase more than ten percent. The percentage unbalance is calculated by taking the maximum deviation from average amperage and dividing it by the average amperage as shown in the following example:

A phase current 38 amps

B phase current 38 amps

C phase current 44 amps

$$\text{Average current} = \frac{38 + 38 + 44}{3} = 40 \text{ amps}$$

$$\text{Maximum Deviation} = 44 - 40 = 4 \text{ amps}$$

$$\text{Percent unbalance} = \frac{\text{maximum deviation}}{\text{average current}} \times 100$$

$$\text{Percent unbalance} = \frac{4}{40} \times 100 = 10\%$$

The Company normally will not install three-phase where single-phase is adequate. Exceptions can be made where it is mutually advantageous to both Company and the Customer. Normally, motors up to and including 10 horsepower rated at NEMA Codes A through G can be served single-phase. It is strongly recommended that no residential customers be served from any single-phase transformer which serves a single-phase motor of 5 horsepower or greater. Three-phase motors connected using add-a-phase are considered as single-phase motors.

SECTION 7

7. SPECIAL TYPES OF SERVICE

7.1 NON-STANDARD CONSTRUCTION

Non-standard construction is contingent upon prior approval by the Company. Standard electric service is provided from a single source of supply under the terms, conditions, and Rules and Regulations of the Company's Tariffs on file and in effect with the Commission. Any change from standard service, which is within the limits prescribed by the Commission, will be at the customer's expense. This includes all engineering, installation, maintenance, and material costs required to provide and maintain this non-standard construction.

Where additional transformer installations are requested solely to limit the size and length of customer-owned services, the additional costs of such installations may be charged to the customer as "Non-Standard Construction".

7.2 DATA PULSES

Meter pulses generated for customer use as data to their load management system.

Data pulses are generated by an electric meter at a rate which is proportional to the load. Customers may purchase data pulses which, when accumulated over a demand interval and multiplied by a pulse value, will represent the customer's demand. The customer's calculated demand and corresponding demand interval will not duplicate the Company's billing demand and demand interval but will be useful in controlling the customer's demand limits.

Customer accessible data pulse wiring will be provided within a junction box located next to the existing meter. A data pulse will consist of a change in state of a Form "C" contact with the "K" lead serving as the common terminal. The meter pulse contacts are rated 100 milliamps at 120 volts AC or DC.

The pulse initiator and the associate pulse value are an integral part of the demand meter. The selection of equipment for a particular installation will determine the pulse value. The pulse value will be provided at the time of pulse installation, but may change due to necessary changes in metering equipment. The kWh pulse value given to the customer will be for a three-wire Form C connection. If the customer's load controller uses a two-wire Form A connection, the kWh pulse value must be multiplied by a factor of 2. The following formula can be used to determine the kWh value per pulse.

$$kWh \text{ Pulse Value} = \frac{K_h \times CT \text{ Ratio} \times PT \text{ Ratio}}{Pulses/Revolution \times 1000}$$

The Company reserves the right to interrupt pulses at any time in order to test or change the meter and to change the pulse value whenever it becomes necessary to upgrade the metering equipment. Every effort will be made to notify the customer when it becomes necessary to interrupt pulses for equipment maintenance. The customer will be notified of any change to the pulse values.

Illustration Section, **Drawing IR-40** shows possible metering configurations supplying customer data pulses.

This Page Intentionally Left Blank

SECTION 8

8. DISTRIBUTED ENERGY RESOURCES

The Company will allow customers to connect on-site generating equipment to the Company's system. Generating equipment can include, but is not limited to, fossil fuel generators, wind turbines, hydro- electric turbines, and photovoltaic (solar) inverters. All generating equipment shall be "non-islanding" per IEEE 1547 unless specifically agreed upon with the Company.

8.1 INTERCONNECTION REQUIREMENTS

The customer shall inform the Company of plans to install and connect generating equipment to the Company's system. It is in the best interest of both the Company and the customer to obtain Company interconnection acceptance and approvals before the customer completes final designs or purchases any equipment. Customer-owned generating equipment shall be installed without causing adverse effects to the Company's or customer's equipment and without introducing potentially dangerous situations to the Company's personnel or the public.

Generation that can operate either momentarily or continuously in parallel with Company facilities shall incorporate protective devices (relays, circuit breakers, etc.) and metering equipment as specified by the Company's Interconnection Guidelines. The customer's installation shall meet state Commission rules for distributed generation, all applicable national, state, and local construction and safety codes, and applicable Federal Energy Regulatory Commission (FERC), regional reliability council, and Open Access Transmission Tariff (OATT) rules.

A copy of the Interconnection Guidelines may be obtained from the Company's website under the Energy Partners Section or the Company Area Engineer that is assigned to the geographic area that includes the proposed generation interconnection site. The specific Interconnection Guideline which is applicable depends on the type, size, and operating mode of the generation that is proposed.

Normally, generation facilities totaling over 10 MW are connected to the area electric transmission system. The local transmission provider should be contacted for a copy of the interconnection requirements for larger facilities. Usually, contact is made with their System Planning group.

The Company will not assume any responsibility for the protection of the customer's facility or any portion of the customer's electrical equipment. The customer is fully responsible for protecting his equipment from damage caused by faults or other disturbances on the Company's system.

The Company will review the customer's design for interconnection acceptance only. The Company will not approve the reliability or adequacy of the customer's design.

8.2 LABELING/PLACARD REQUIREMENTS

All required labels or placards shall be weatherproof, durable, and permanently (screws or rivets) attached to the meter socket, or other equipment as necessary. Check with the local Area Engineering Department for additional requirements such as, sizing, color scheme, and verbiage.

8.2.1 Generators Operating as a Backup Source

For generating equipment that is designed to operate as a backup source consult the state rules or Company Area Engineering Department.

8.2.2 Generators Operating as a Parallel Source

For generating equipment designed to operate in parallel with the utility grid the following labels are required in addition to any labels required by the state or Authority Having Jurisdiction:

1. "Generation System Connected" or similar located on or directly adjacent to the revenue meter socket.
2. "Utility AC Disconnect" located on the utility accessible AC disconnect when an AC disconnect is required to be installed.
3. If the AC disconnect is not within close proximity to the Company's revenue meter, the customer shall post at the revenue meter a clearly labeled map showing the location of the revenue meter, the AC disconnect, production meter (if applicable), and generation facility.

8.3 METERING REQUIREMENTS

Certain types of generating equipment may qualify for net metering. Check the tariffs on file with the local utility or regulatory commission for net metered rates.

8.3.1 Net Metering

Net meters are bi-directional meters that measure both directions of power flow and are typically used on distributed energy resources (distributed generation) that utilizes renewable energy sources. Metering both directions of power flow allows customers to generate in parallel with the Company and sell back excess generation. Selling back excess generation is subject to Rules and Regulations on file with the local utility commission or regulatory body.

8.3.2 Production Meters

Production meters, if required, are Company meters that measure the gross generation of a distribution connected generator. When production meters are utilized, there are additional requirements to ensure the safety of our personnel and the public.

1. A single point of manual AC disconnect, with a visible open and lockable in the off position, shall be installed between the generation source and the production meter, adjacent to the production meter, except in NM.
2. The customer supplied production meter socket or CT compartment shall meet all of the requirements in Section 4.
3. The production meter shall be located within ten (10) feet of the existing billing meter. If this cannot be accomplished, additional labeling at each meter directing personnel to the other meter location is required. Production meter locations will be addressed during the engineering review; exception requests are not necessary. Approval from the local Electric Meter Shop may also be required.
4. Self-contained production meter sockets shall have the generation source wired to the line side terminals of the self-contained meter socket. When instrument transformers are utilized for the production meter, the H1 polarity marking shall be facing the customer generation source.
5. The production meter socket shall be labeled in accordance with the requirements in Section 4.14.3 under Meter Identification.

A customer-owned production meter may be installed at the Customer's expense. This meter will not be supplied or maintained by the Company. If the customer-owned production meter is in series with the

Company required production meter, there shall be a manual means of disconnect between the two production meters.

8.3.3 AC Disconnect Requirements

A manual disconnecting device, capable of interrupting the rated generator and/or load current, accessible to the Company's personnel, and which can be locked open with a visible open for line clearances, must be provided. The visible open shall be viewable without unbolting covers or assistance from site personnel. The switch must be accessible to the Company personnel without assistance from site personnel. The form of this device will vary with the service voltage and generator capacity.

The manual disconnect switch must be clearly marked with a permanent, weather-proof label. For generation facilities where the switch and/or production meter are not located in close proximity to the Company's revenue meter, the Customer must post at the revenue meter a permanent, weather-proof, clearly labeled map or diagram showing the location of the revenue meter, the switch, production meter, and generation facility.

8.4 TELEMETRY REQUIREMENTS

Telemetry may be required for Distributed Energy Resources based on jurisdictional rules and regulations. Special metering or a communication enclosure will be provided by the Company for the purposes of relaying the data from the Company metering for monitoring and load control. If applicable, the customer is responsible for mounting the enclosure, disconnect switch, and providing power and site Local Area Network (LAN) connectivity to the enclosure. Check with the local Area and Metering Engineering Departments for additional details.

This Page Intentionally Left Blank

Selecting the Correct Self-Contained Meter Socket

Self-contained meter sockets for services less than 600 volts and up to 320 amps

SINGLE-PHASE SERVICE	PROPER METER SOCKET
120 Volts 2-Wire	5 - Terminal
277 Volts 2-Wire	5 - Terminal
480 Volts 2-Wire	5 - Terminal
120/240 Volts 3-Wire	5 - Terminal
120/208 Volts 3-Wire	5 - Terminal
240/480 Volts 3-Wire	5 - Terminal

THREE-PHASE SERVICE	PROPER METER SOCKET
120/208 Volts 4-Wire	7 - Terminal
120/240 Volts 4-Wire	7 - Terminal
277/480 Volts 4-Wire	7 - Terminal
240 Volts or 480 Volts 3-Wire (Corner grounded)	5 - Terminal

Note: Check Section 3.1.1 for available service voltages by state.

TABLE OF RESPONSIBILITY

Drawing SC-10		
ITEM, MATERIAL OR WORK DESCRIPTION	PARTY TO FURNISH, OWN AND MAINTAIN	PARTY TO INSTALL
Permits and Inspections	Customer	N/A
Overhead Service Drop	<i>Company</i>	<i>Company</i>
Service Connection	<i>Company</i>	<i>Company</i>
Service Entrance Conduit, Conductor, and OH Point of Attachment	Customer	Customer
Meter Socket	Customer	Customer
Billing Meter	<i>Company</i>	<i>Company</i>
Load Side Conduit and Conductor	Customer	Customer
Ice and Snow Shield, if Required	Customer	Customer
Ground Rod(s)	Customer	Customer

Point of Delivery:

Overhead Service Residential/Commercial – Point where the *Company's* facilities are first connected to the electric facilities of the customer.

DRAWING SC-10

SELF-CONTAINED METER INSTALLATION FROM AN OVERHEAD SECONDARY SUPPLY

Services up to 320 amp 1Ø-3Ø
Residential or Commercial
(Hot Sequence Installation Shown)

Point of attachment shall not exceed 24' above grade.
Foreign attachments to meter housing mast or riser are not permitted.
The neutral wire from the 5th terminal on single-phase and the 7th terminal on 3-phase, 4-wire shall be connected to neutral within meter socket.

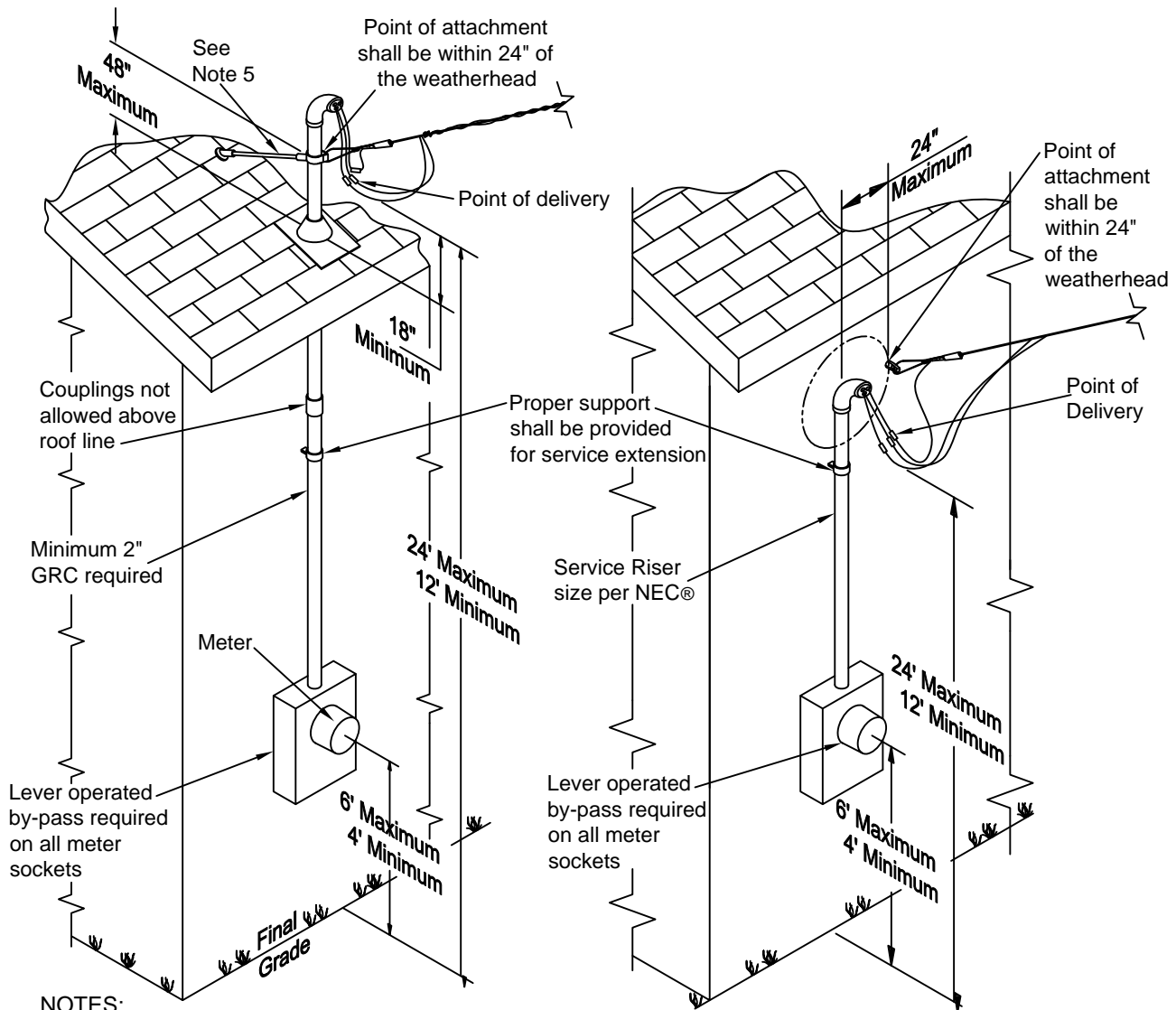

NOTES:

1. Ground rod furnished and installed by customer per NEC®.
2. Clearances shall conform to current edition of NESC®.
3. The use of a mast may be required above 6000 feet elevation.
4. See [Section 4.2.1\(4\)](#) and check with the Company's local Electric Meter Department to determine if a service mast and/or ice and snow shield are required. Refer to Drawings [SC-20](#) and [SC-20A](#) for details.
5. Masts shall be braced if the weatherhead exceeds 48". The company may require bracing for the weatherhead at 48" or under.
6. See [Sections 4.17](#) and [4.18](#) for cold and hot sequence metering requirements.

TABLE OF RESPONSIBILITY

Drawing SC-20 & 20A		
ITEM, MATERIAL OR WORK DESCRIPTION	PARTY TO FURNISH, OWN AND MAINTAIN	PARTY TO INSTALL
Permits and Inspections	Customer	N/A
Overhead Service Drop	Company	Company
Underground Service Lateral (Residential)	Company*	Company*
Underground Service Lateral (Commercial) (except WI and MI)	Customer*	Customer*
Service Entrance Conduit and OH Point of Attachment	Customer	Customer
Meter Socket	Customer	Customer
Billing Meter	Company	Company
Load Side Conduit and Conductor	Customer	Customer
Ice and Snow Shield, if Required	Customer	Customer
Ground Rod(s)	Customer	Customer

Point of Delivery:

Overhead Service Residential/Commercial – Point where the *Company's* facilities are first connected to the electric facilities of the customer.

Underground Service Residential (6 meters or fewer)

- At line side terminals of meter socket; or
- Line side of disconnect if main disconnect is used ahead of metering.

Underground Service Commercial – Point where the *Company's* facilities are first connected to the electric facilities of the customer.

* Note: In TX/NM only, all Overhead to Underground Service Laterals that do not utilize a secondary pedestal will be Company owned. For service laterals extending directly from a pad mounted transformer, residential services will be Company owned while commercial services will be Customer owned unless Customer owned metering cabinet is on the same pad as the transformer. For all installations utilizing a secondary connection cabinet or a secondary pedestal, the Service Lateral will be Customer owned.

DRAWING SC-20

METER ICE AND SNOW SHIELD
(Hot Sequence Installation Shown)

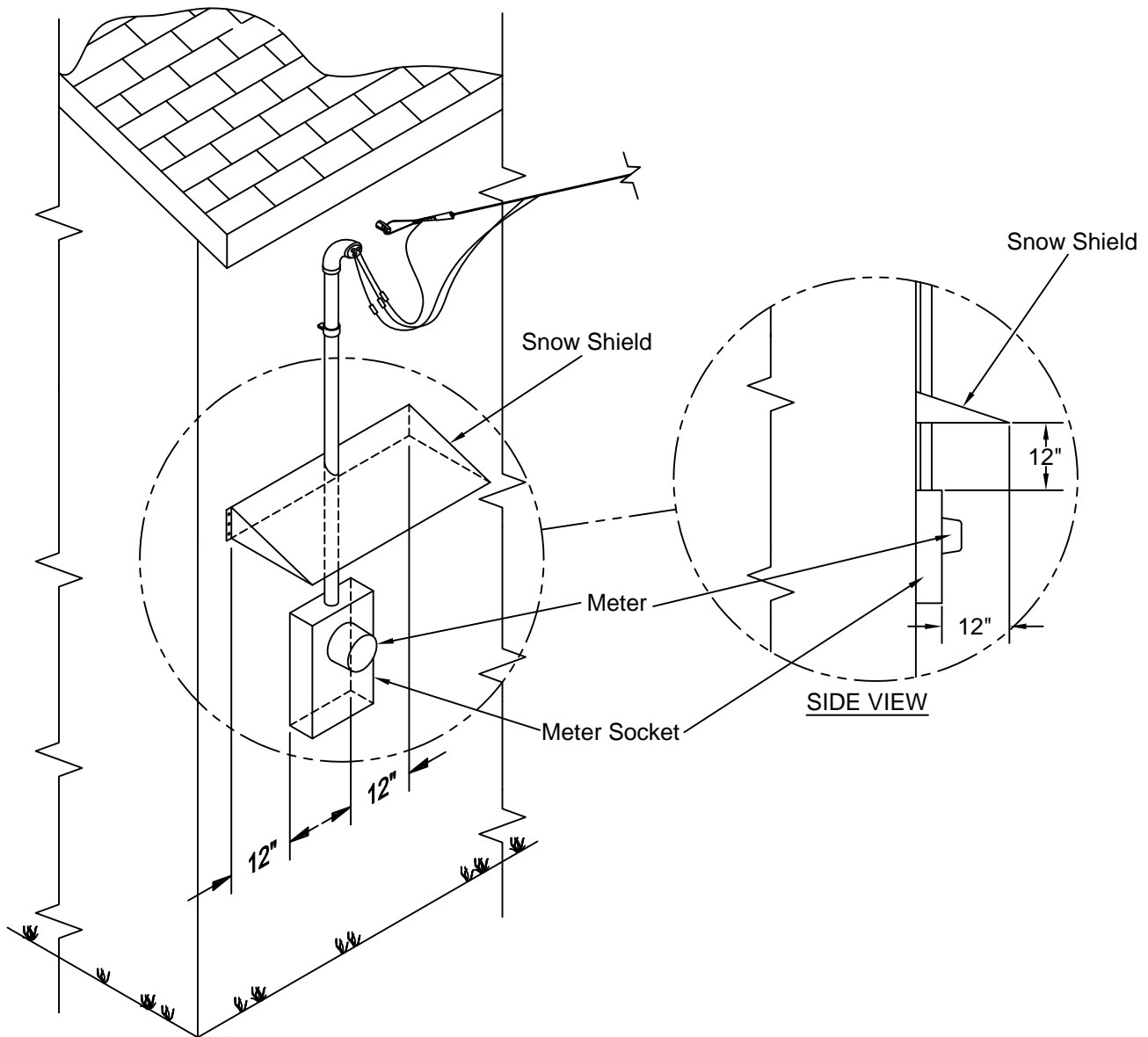

NOTES:

1. Shield must be capable of protecting meter.
2. Meter socket must have minimum 12" clearance from shield in all directions.
3. Check with company's local Electric Meter Department to determine if ice and snow shield is required.
4. Not allowed in the following CO counties: Eagle, Lake, Park, and Summit.

DRAWING SC-20A

METER ICE AND SNOW SHIELD (Hot Sequence Installation Shown)

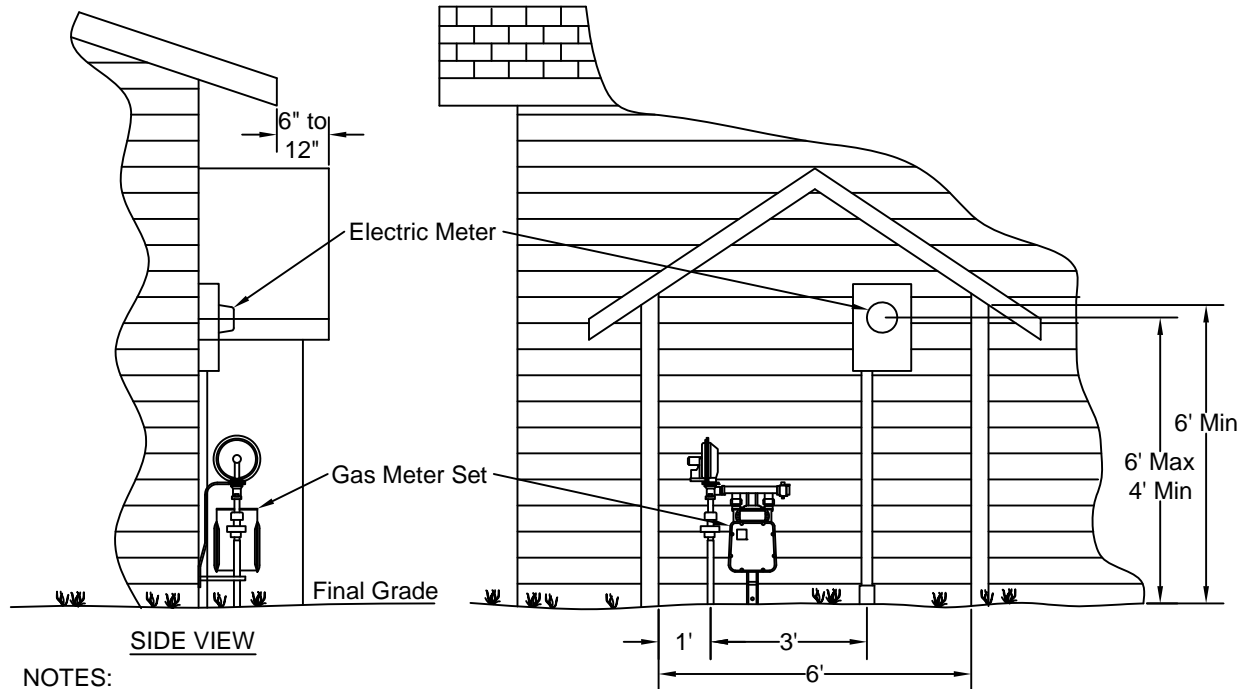

NOTES:

1. Required meter protection will consist of walls and gable roof which are structurally part of the building.
2. Walls will be 6' high and 6' apart.
3. Gable roof will extend a minimum of 6" beyond drip line (preferably 12").
4. Meters will not be set until meter protection is in place and approved by Xcel Energy.
5. Not allowed in the following CO counties: Eagle, Lake, Park, and Summit.

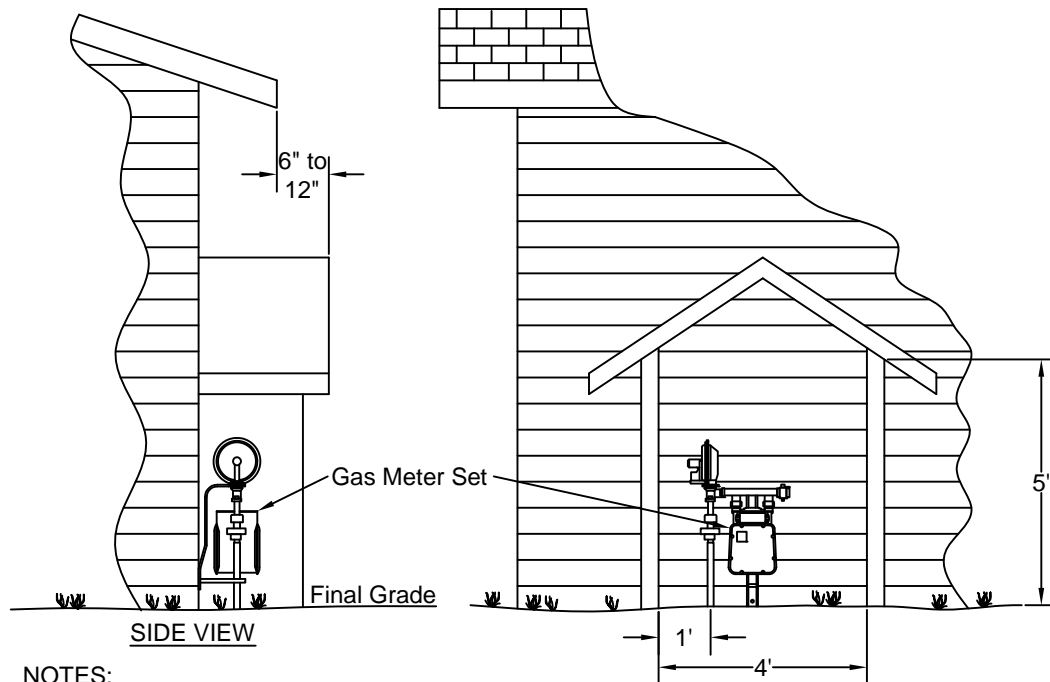

NOTES:

1. Required meter protection will consist of walls and gable roof which are structurally part of the building.
2. Walls will be 5' high and 4' apart.
3. Gable roof will extend a minimum of 6" beyond drip line (preferably 12").
4. Meters will not be set until meter protection is in place and approved by Xcel Energy.
5. Not allowed in the following CO counties: Eagle, Lake, Park, and Summit.

This Page Intentionally Left Blank

TABLE OF RESPONSIBILITY

Drawing SC-30		
ITEM, MATERIAL OR WORK DESCRIPTION	PARTY TO FURNISH, OWN AND MAINTAIN	PARTY TO INSTALL
Permits and Inspections	Customer	N/A
Underground Service Lateral (Residential)	<i>Company</i>	<i>Company</i>
Underground Service Lateral (Commercial) (except WI and MI)	Customer	Customer
Slip Sleeve/Expansion Joint	Customer	Customer
Service Entrance Conduit	Customer	Customer
Meter Socket	Customer	Customer
Line Side Conductor Terminations (except WI and MI)	Customer	Customer
Billing Meter	<i>Company</i>	<i>Company</i>
Load Side Conduit and Conductor	Customer	Customer
Ground Rod(s)	Customer	Customer

Point of Delivery:

Underground Service Residential (6 meters or fewer)

- At line side terminals of meter socket; or
- Line side of disconnect if main disconnect is used ahead of metering.

Underground Service Commercial – Point where the *Company's* facilities are first connected to the electric facilities of the customer.

* Note: In TX/NM only, all Overhead to Underground Service Laterals that do not utilize a secondary pedestal will be Company owned. For service laterals extending directly from a pad mounted transformer, residential services will be Company owned while commercial services will be Customer owned unless Customer owned metering cabinet is on the same pad as the transformer. For all installations utilizing a secondary connection cabinet or a secondary pedestal, the Service Lateral will be Customer owned.

DRAWING SC-30

DIRECT BURIAL FROM
AN UNDERGROUND SECONDARY SUPPLY
Services up to 320 amp 1Ø-3Ø
Residential or Commercial
(Hot Sequence Installation Shown)

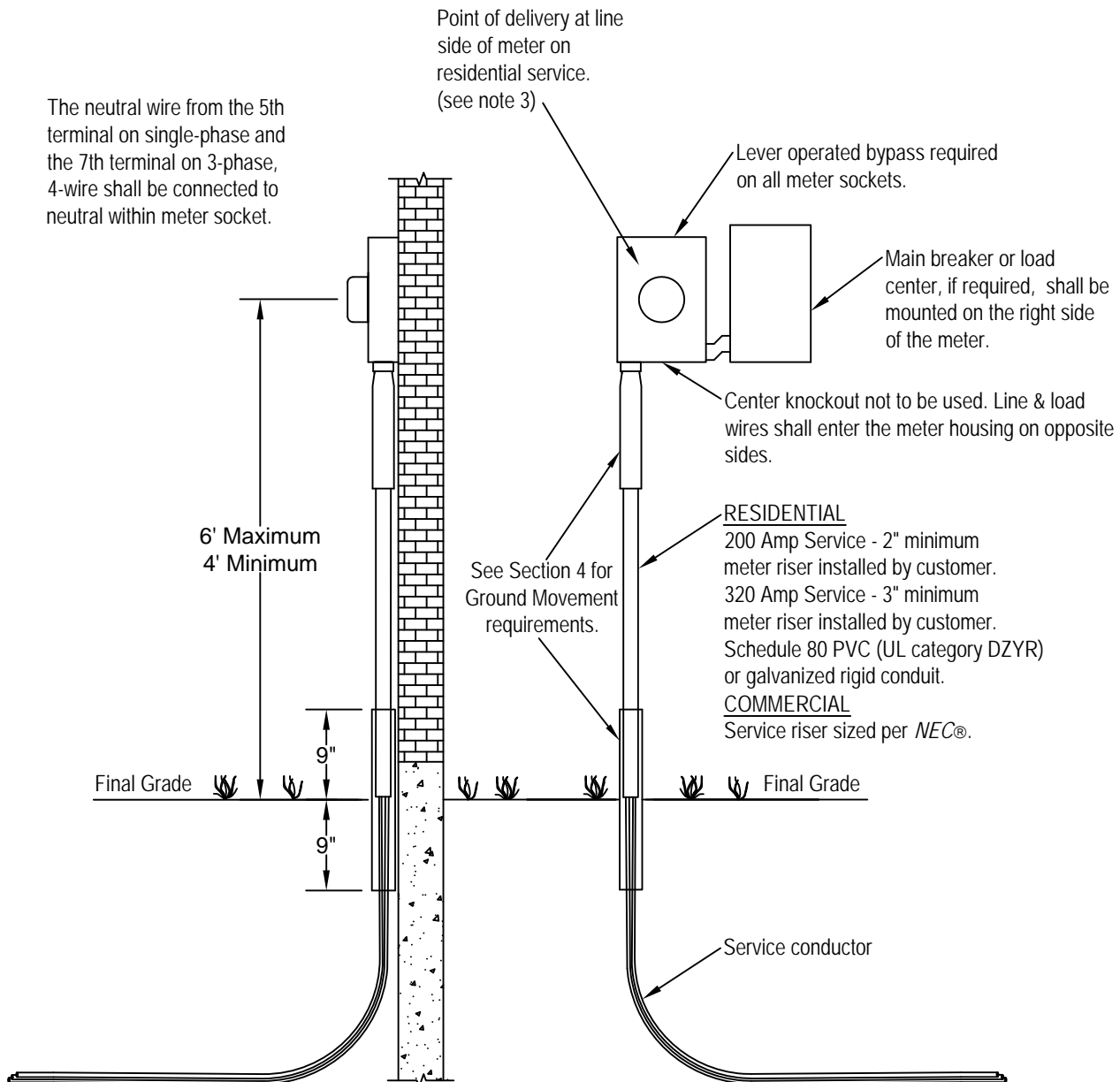

NOTES:

1. See [Sections 4.17](#) and [4.18](#) for cold and hot sequence metering requirements.
2. See [Section 4.3.1\(3\)](#) and check with the Company's local Electric Meter Department to determine if ice and snow shield are required. Refer to Drawing [SC-20](#) and [SC-20A](#) for details.
3. Point of delivery at Company facilities on commercial service in Wisconsin and Michigan.

TABLE OF RESPONSIBILITY

Drawing SC-40		
ITEM, MATERIAL OR WORK DESCRIPTION	PARTY TO FURNISH, OWN AND MAINTAIN	PARTY TO INSTALL
Permits and Inspections	Customer	N/A
Underground Service Lateral (Residential)	<i>Company</i>	<i>Company</i>
Underground Service Lateral (Commercial) (except WI and MI)	Customer	Customer
Slip Sleeve/Expansion Joint	Customer	Customer
Service Entrance Conduit	Customer	Customer
Service Entrance Conduit Under Hard Surface	Customer	Customer
Meter Socket	Customer	Customer
Line Side Conductor Terminations (except WI and MI)	Customer	Customer
Billing Meter	<i>Company</i>	<i>Company</i>
Load Side Conduit and Conductor	Customer	Customer
Ground Rod(s)	Customer	Customer

Point of Delivery:

Underground Service Residential (6 meters or fewer)

- At line side terminals of meter socket; or
- Line side of disconnect if main disconnect is used ahead of metering.

Underground Service Commercial – Point where the *Company's* facilities are first connected to the electric facilities of the customer.

* Note: In TX/NM only, all Overhead to Underground Service Laterals that do not utilize a secondary pedestal will be Company owned. For service laterals extending directly from a pad mounted transformer, residential services will be Company owned while commercial services will be Customer owned unless Customer owned metering cabinet is on the same pad as the transformer. For all installations utilizing a secondary connection cabinet or a secondary pedestal, the Service Lateral will be Customer owned.

DRAWING SC-40

DIRECT BURIAL UNDER HARD SURFACE FROM AN UNDERGROUND SECONDARY SUPPLY

Services up to 320 amp 1Ø-3Ø

Residential or Commercial

(Hot Sequence Installation Shown)

Installation of conduit under patio, sidewalk, driveway or other surface obstruction

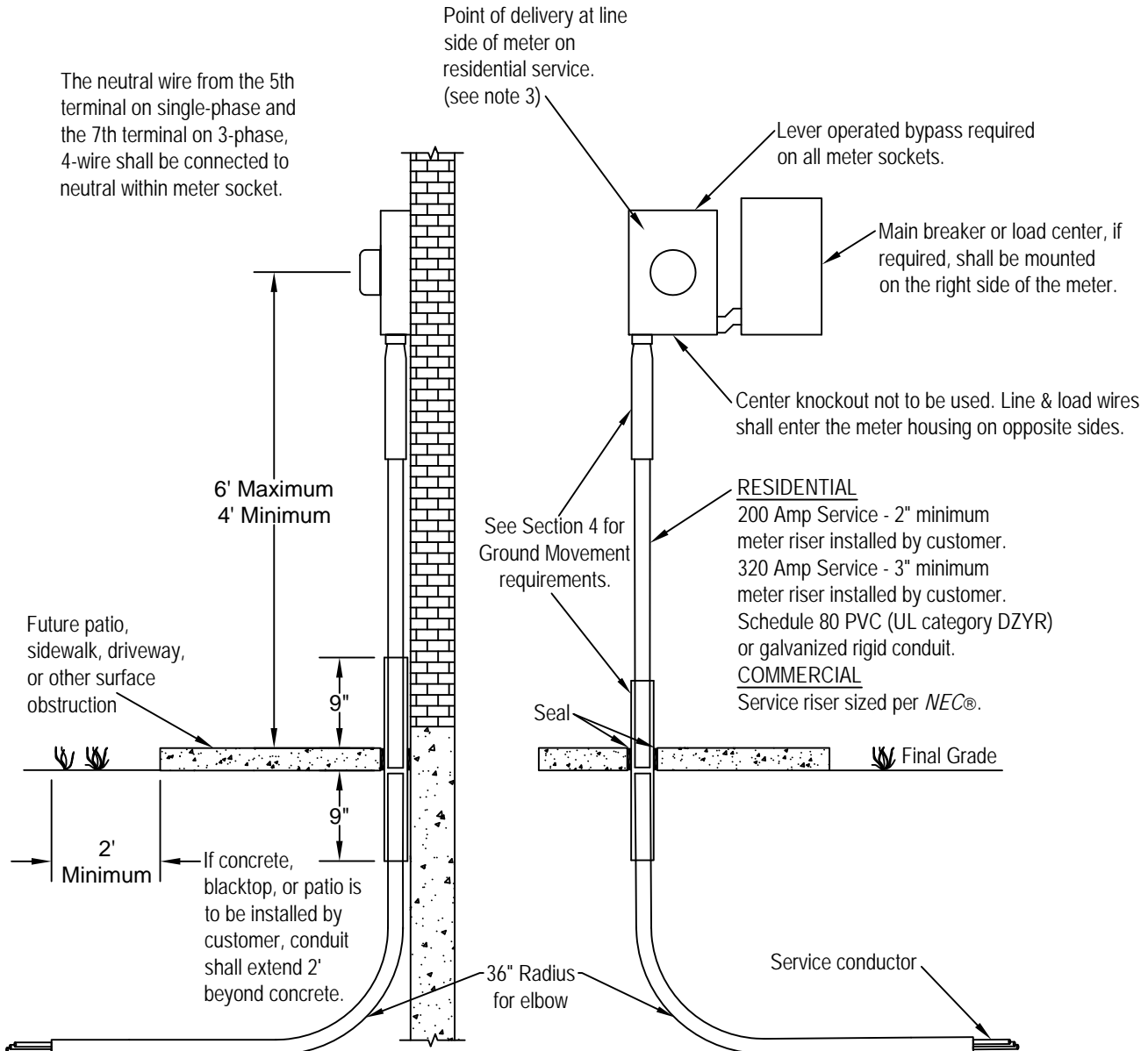

NOTES:

1. See [Sections 4.17](#) and [4.18](#) for cold and hot sequence metering requirements.
2. See [Section 4.3.1\(3\)](#) and check with the Company's local Electric Meter Department to determine if ice and snow shield are required. Refer to Drawing [SC-20](#) and [SC-20A](#) for details.
3. Point of delivery at Company facilities on commercial service in Wisconsin and Michigan.

TABLE OF RESPONSIBILITY

Drawing SC-50		
ITEM, MATERIAL OR WORK DESCRIPTION	PARTY TO FURNISH, OWN AND MAINTAIN	PARTY TO INSTALL
Permits and Inspections	Customer	N/A
Underground Service Lateral (Residential)	<i>Company</i>	<i>Company</i>
Underground Service Lateral (Commercial) (except WI and MI)	Customer	Customer
Slip Sleeve/Expansion Joint	Customer	Customer
Service Entrance Conduit	Customer	Customer
Meter Socket	Customer	Customer
Meter Socket Mounting Structure	Customer	Customer
Line Side Conductor Terminations (except WI and MI)	Customer	Customer
Billing Meter	<i>Company</i>	<i>Company</i>
Load Side Conduit and Conductor	Customer	Customer
Ground Rod(s)	Customer	Customer

Point of Delivery:

Underground Service Residential (6 meters or fewer)

- At line side terminals of meter socket; or
- Line side of disconnect if main disconnect is used ahead of metering.

Underground Service Commercial – Point where the *Company's* facilities are first connected to the electric facilities of the customer.

* Note: In TX/NM only, all Overhead to Underground Service Laterals that do not utilize a secondary pedestal will be Company owned. For service laterals extending directly from a pad mounted transformer, residential services will be Company owned while commercial services will be Customer owned unless Customer owned metering cabinet is on the same pad as the transformer. For all installations utilizing a secondary connection cabinet or a secondary pedestal, the Service Lateral will be Customer owned.

DRAWING SC-50

PERMANENT SERVICE INSTALLATION FROM AN UNDERGROUND SECONDARY SUPPLY

Services up to 320 amp 1Ø-3Ø
Residential or Commercial
(Hot Sequence Installation Shown)

Installation shall be outside of the utility easement and shall be more than 6' from the service pedestal, pull box or pad-mounted transformer.

PREFERRED INSTALLATION

ALTERNATIVE SINGLE POST INSTALLATION*

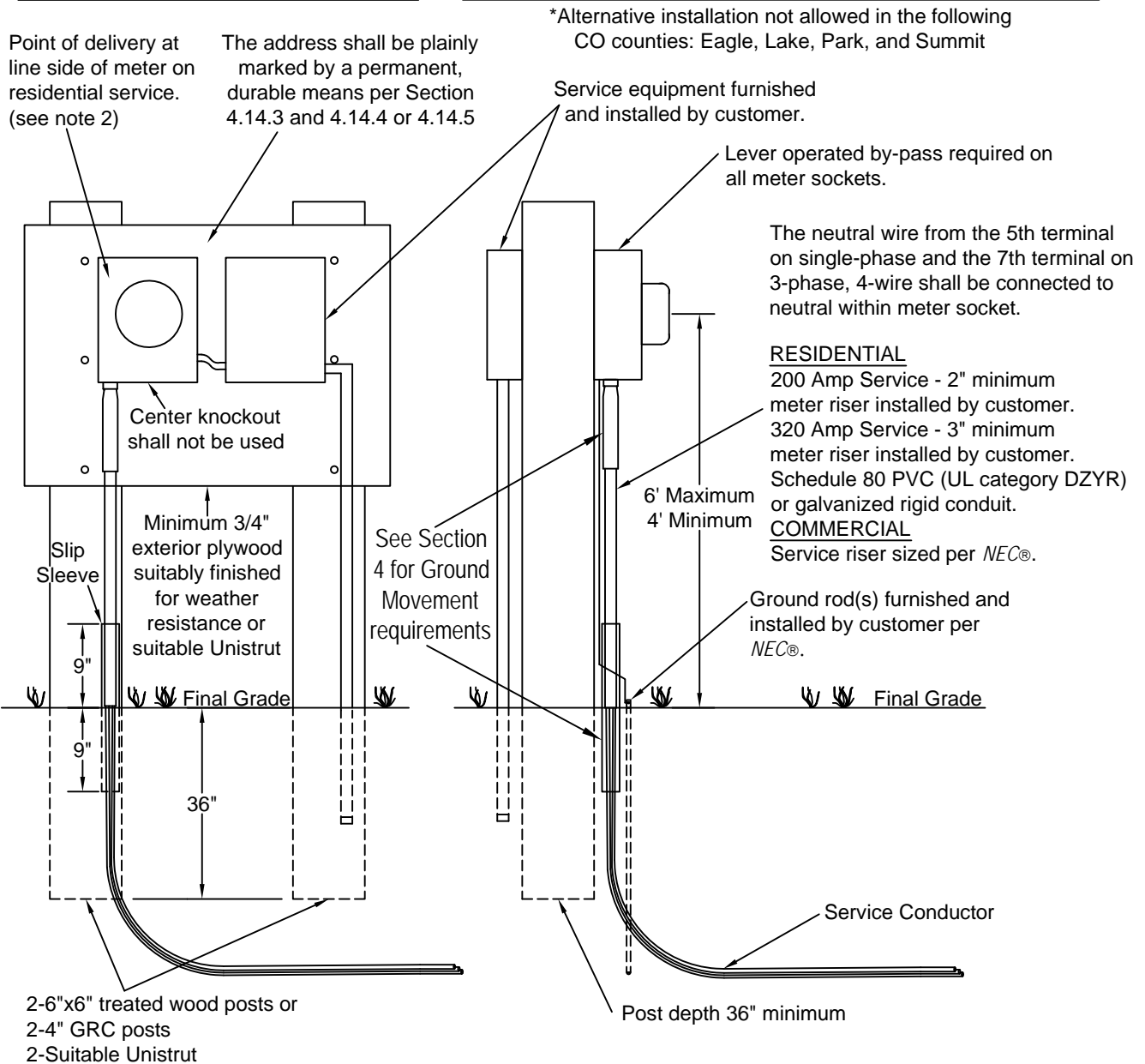

*Alternative installation not allowed in the following CO counties: Eagle, Lake, Park, and Summit

NOTE:

1. See Sections 4.17 and 4.18 for cold and hot sequence metering requirements.
2. Point of delivery at Company facilities on commercial service in Wisconsin and Michigan.

TABLE OF RESPONSIBILITY

Drawing SC-60		
ITEM, MATERIAL OR WORK DESCRIPTION	PARTY TO FURNISH, OWN AND MAINTAIN	PARTY TO INSTALL
Permits and Inspections	Customer	N/A
Underground Service Lateral (Residential)	Company	Company
Underground Service Lateral (Commercial) (except WI and MI)	Customer	Customer
Service Entrance Conduit Under Hard Surface	Customer	Customer
Meter Pedestal	Customer	Customer
Meter Pedestal Extension Unit (Required)	Customer	Customer
Line Side Conductor Terminations (except WI and MI)	Customer	Customer
Billing Meter	Company	Company
Load Side Conduit and Conductor	Customer	Customer
Ground Rod(s)	Customer	Customer

Point of Delivery:

Underground Service Residential (6 meters or fewer)

- At line side terminals of meter socket; or
- Line side of disconnect if main disconnect is used ahead of metering.

Underground Service Commercial – Point where the *Company's* facilities are first connected to the electric facilities of the customer.

* Note: In TX/NM only, all Overhead to Underground Service Laterals that do not utilize a secondary pedestal will be Company owned. For service laterals extending directly from a pad mounted transformer, residential services will be Company owned while commercial services will be Customer owned unless Customer owned metering cabinet is on the same pad as the transformer. For all installations utilizing a secondary connection cabinet or a secondary pedestal, the Service Lateral will be Customer owned.

DRAWING SC-60

METER PEDESTAL ATTACHED TO BUILDING FROM AN UNDERGROUND SECONDARY SUPPLY

Services up to 320 amp 1Ø-3Ø
Residential or Commercial
(Hot Sequence Installation Shown)

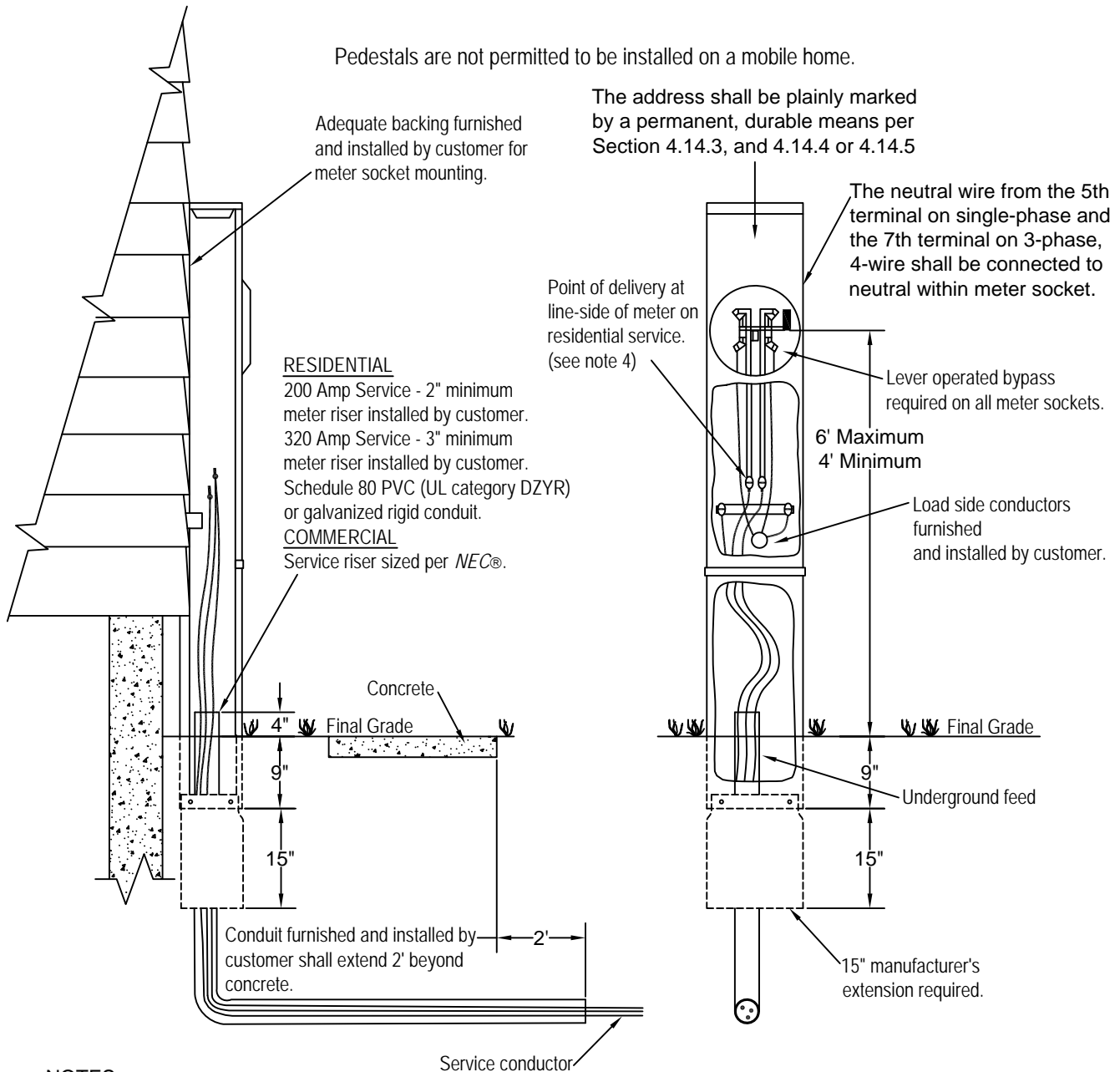

NOTES:

1. Adequate space shall be provided for removal of meter pedestal cover when underground conductors are located beneath concrete.
2. If concrete is to be installed, conduit shall be furnished and installed by customer. Conduit shall extend 2' beyond concrete and 4" above final grade.
3. 15" manufacturer's extension required to be installed on all pedestals.
4. Point of delivery at Company facilities on commercial service in Wisconsin and Michigan.

TABLE OF RESPONSIBILITY

Drawing SC-70, 70A & 70B		
ITEM, MATERIAL OR WORK DESCRIPTION	PARTY TO FURNISH, OWN AND MAINTAIN	PARTY TO INSTALL
Permits and Inspections	Customer	N/A
Underground Service Lateral (Residential)	Company	Company
Underground Service Lateral (Commercial) (except WI and MI)	Customer	Customer
Service Entrance Conduit Under Hard Surface	Customer	Customer
Meter Pedestal	Customer	Customer
Meter Pedestal Mounting Base or Direct Burial Kit	Customer	Customer
Concrete Pad If Required	Customer	Customer
Line Side Conductor Terminations (except WI and MI)	Customer	Customer
Billing Meter	Company	Company
Load Side Conduit and Conductor	Customer	Customer
Ground Rod(s)	Customer	Customer

Point of Delivery:

Underground Service Residential (6 meters or fewer)

- At line side terminals of meter socket; or
- Line side of disconnect if main disconnect is used ahead of metering.

Underground Service Commercial – Point where the *Company's* facilities are first connected to the electric facilities of the customer.

* Note: In TX/NM only, all Overhead to Underground Service Laterals that do not utilize a secondary pedestal will be Company owned. For service laterals extending directly from a pad mounted transformer, residential services will be Company owned while commercial services will be Customer owned unless Customer owned metering cabinet is on the same pad as the transformer. For all installations utilizing a secondary connection cabinet or a secondary pedestal, the Service Lateral will be Customer owned.

DRAWING SC-70

DIRECT BURIAL OR FREE STANDING PEDESTAL FROM AN UNDERGROUND SECONDARY SUPPLY

Services up to 320 amp 1Ø-3Ø
Mobile Home, Area Lighting, Sprinkler System etc.
Residential or Commercial

Pedestals are not permitted to be installed in or on a mobile home.

Installation shall be outside the utility easement and shall be more than 6' from the service pedestal, pull box or pad-mounted transformer.

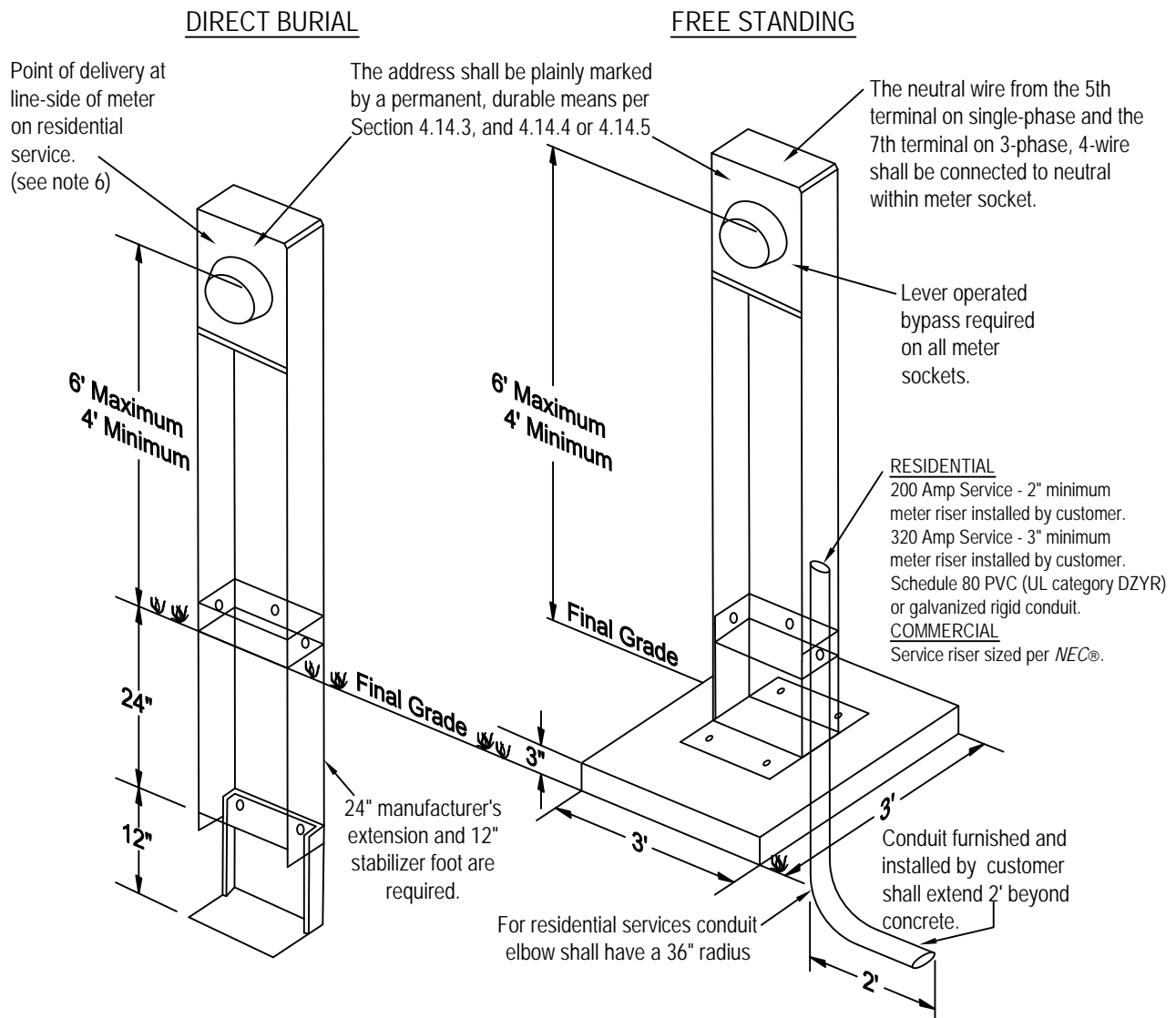

NOTES:

1. The free standing pedestal with a manufacturer's footing base shall be mounted on a 3' x 3' x 3" concrete pad with 95% ground compaction to prevent settling of pad.
2. The direct burial pedestal shall have manufacturer's extension and stabilizer installed.
3. The meter pedestal shall be installed to maintain vertical alignment throughout the life of the installation.
4. The electric meter shall face away from the mobile home and preferably face the driveway or road.
5. See Sections 4.17 and 4.18 for cold and hot sequence metering requirements.
6. Point of delivery at Company facilities on commercial service (except in Wisconsin and Michigan).

DRAWING SC-70A

INSTALLATION OF COMMUNICATIONS PAD-MOUNTED POWER SUPPLY

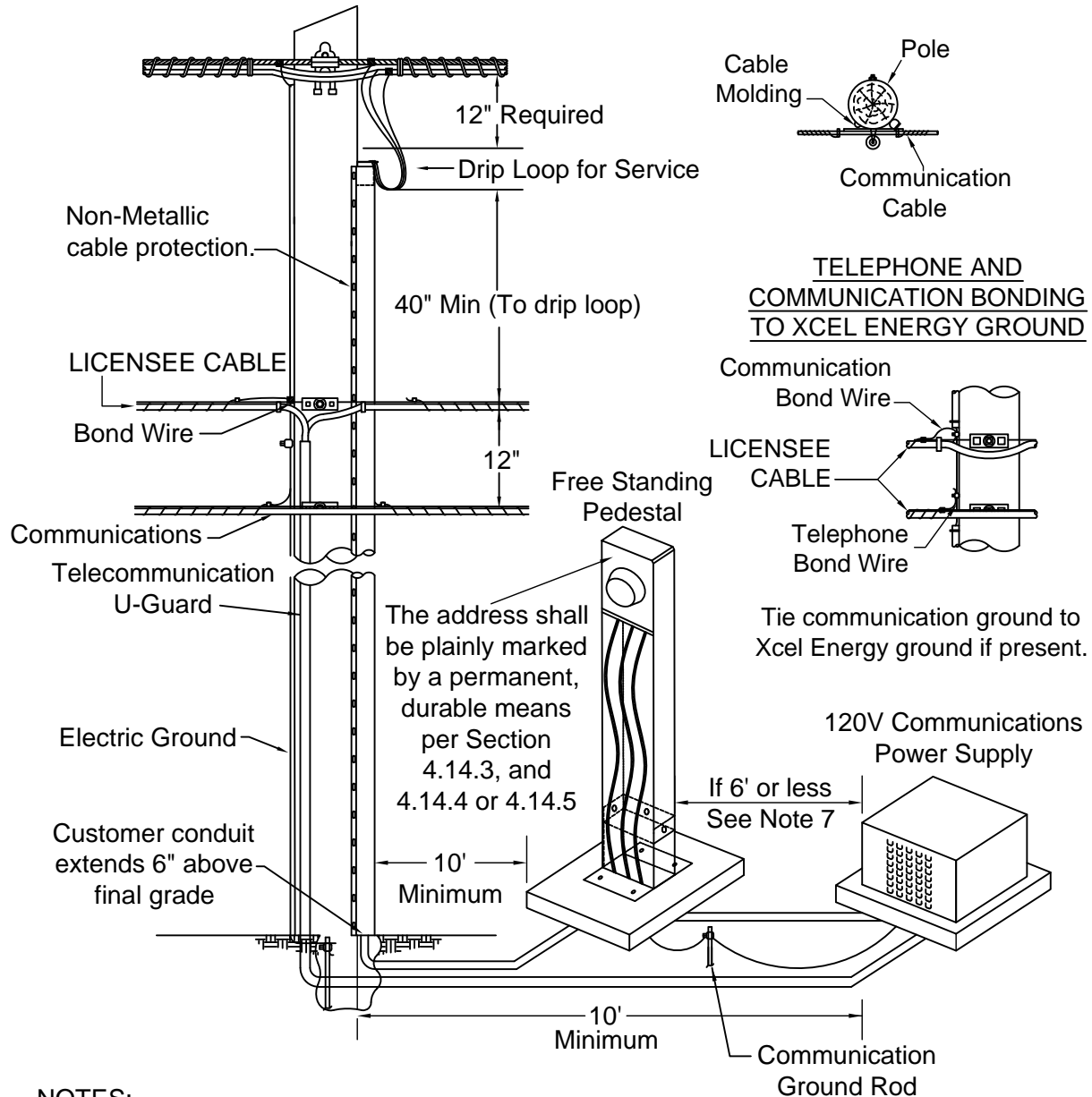

NOTES:

1. Place power supply box a minimum of 10' from pole for working room.
2. If communications ground on pole bond to Xcel Energy ground.
3. U-Guard for power and telecommunication cable must be on same side of pole.
4. Telecommunications power supply box to be grounded with separate ground rod.
5. Power supplies shall not be mounted on poles. They shall be pad-mounted as shown above.
6. Meters may not be installed on company poles.
7. NESC 384.C - Bonding should be provided between all above ground metallic power and communications apparatus (pedestals, terminals, apparatus cases, transformer cases, etc.) that are separated by a distance of 1.8 m (6 ft) or less. For the purpose of this rule, pole grounds are not considered an aboveground metallic power apparatus and therefore not required to be bonded to the communication apparatus.

DRAWING SC-70B

INSTALLATION OF COMMUNICATIONS PAD-MOUNTED POWER SUPPLY

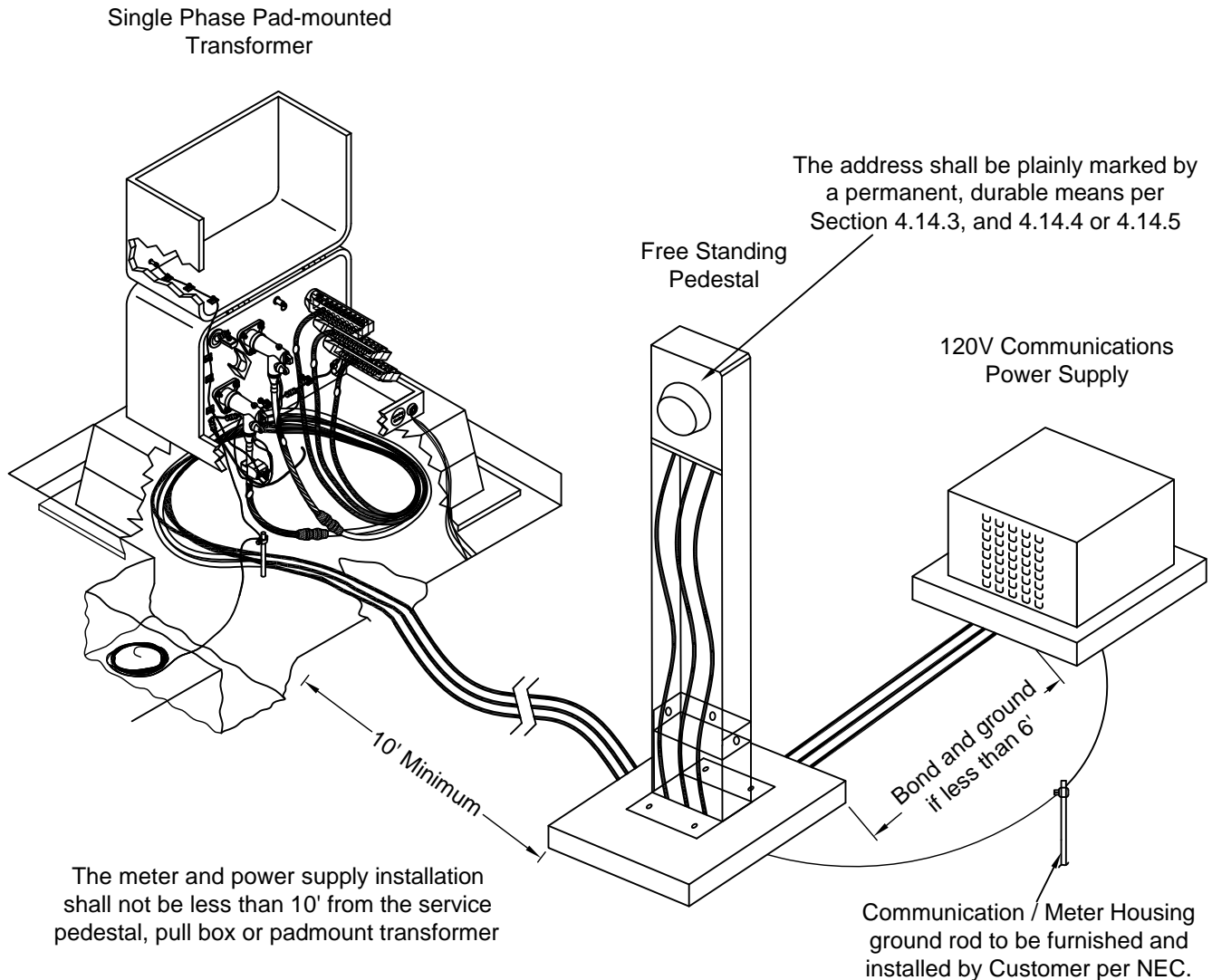

Notes:

1. NESC 384.C

Bonding should be provided between all above ground metallic power and communications apparatus (pedestals, terminals, apparatus cases, transformer cases, etc.) that are separated by a distance of 1.8 m (6 ft) or less. For the purpose of this rule, pole grounds are not considered an aboveground metallic power apparatus and therefore not required to be bonded to the communication apparatus.

TABLE OF RESPONSIBILITY

Drawing SC-80		
ITEM, MATERIAL OR WORK DESCRIPTION	PARTY TO FURNISH, OWN AND MAINTAIN	PARTY TO INSTALL
Permits and Inspections	Customer	N/A
Pole	Customer	Customer
Overhead Service Drop	<i>Company*</i>	<i>Company*</i>
Service Entrance Conduit and Conductor and OH Point of Attachment	Customer*	Customer*
Meter Socket(s)	Customer	Customer
Meter Socket Mounting Structure	Customer	Customer
Optional Wireway	Customer	Customer
Billing Meter(s)	<i>Company</i>	<i>Company</i>
Load Side Conduit and Conductor(s)	Customer	Customer
Ground Rod(s)	Customer	Customer

Point of Delivery:

Overhead Service Residential/Commercial – Point where the *Company's* facilities are first connected to the electric facilities of the customer.

* Note: In TX/NM only, all Overhead to Underground Service Laterals that do not utilize a secondary pedestal will be Company owned. For service laterals extending directly from a pad mounted transformer, residential services will be Company owned while commercial services will be Customer owned unless Customer owned metering cabinet is on the same pad as the transformer. For all installations utilizing a secondary connection cabinet or a secondary pedestal, the Service Lateral will be Customer owned.

DRAWING SC-80

PERMANENT SERVICE INSTALLATION FROM AN OVERHEAD SECONDARY SUPPLY Services up to 320 amp 1Ø-3Ø Residential or Commercial

Installation shall be outside the utility easement.

Meter pole furnished, installed and owned by customer
Utility Pole Designation = Class 7 minimum or Class 6
Pole Height = 25' Minimum
Pole Strength = 1200 ft-lb minimum 5'-6" embedded per CR-110
Circumference = at ground line 23.5", at pole top 15"
Pole must be treated to prevent ground line decay.

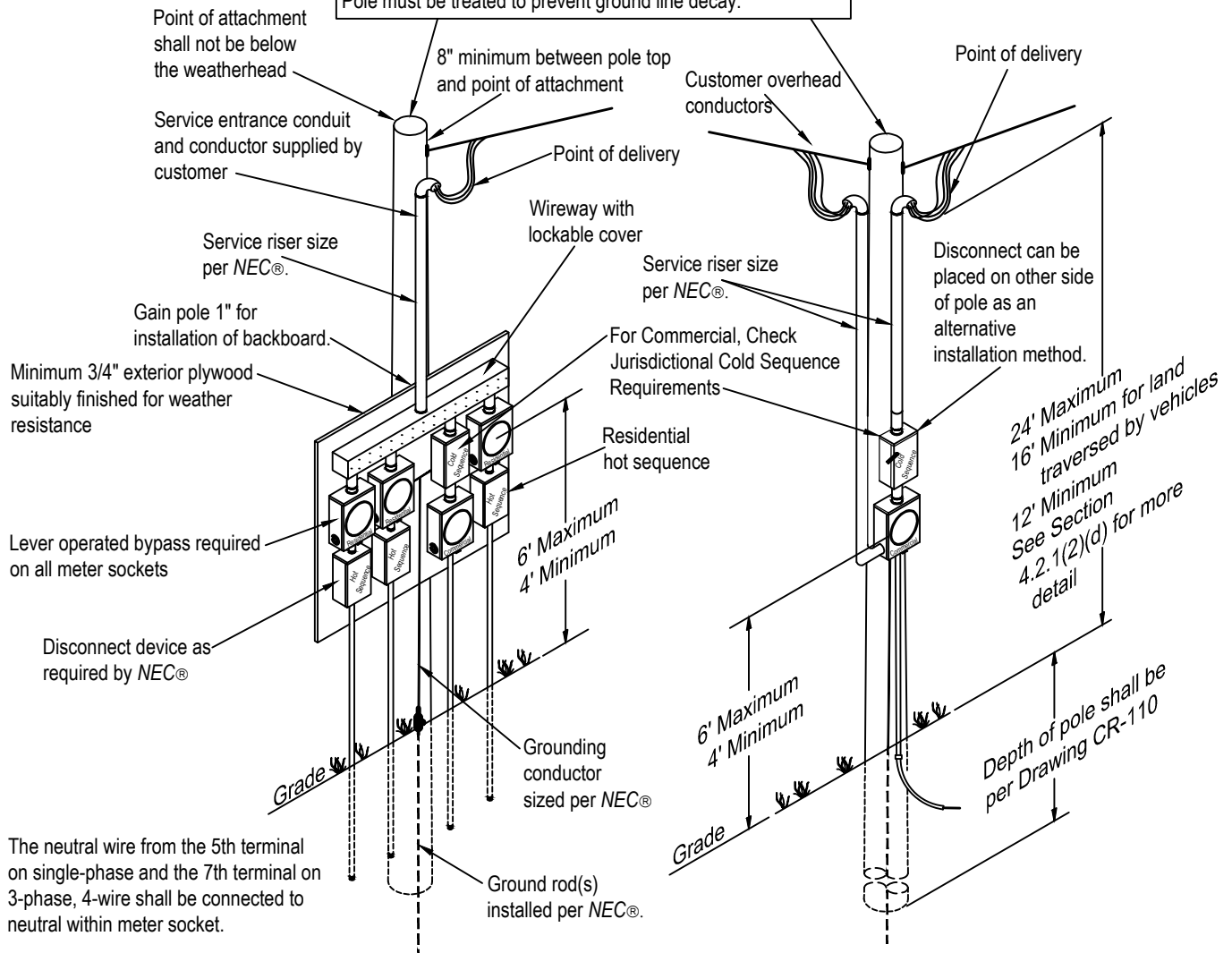

NOTES:

1. See Sections 4.14.3, 4.14.4, and 4.14.5 for meter socket identification requirements.
2. See Sections 4.17 and 4.18 for cold and hot sequence metering requirements.
3. Ground rod(s) and conductor furnished and installed by customer per NEC®.

TABLE OF RESPONSIBILITY

Drawing SC-90		
ITEM, MATERIAL OR WORK DESCRIPTION	PARTY TO FURNISH, OWN AND MAINTAIN	PARTY TO INSTALL
Permits and Inspections	Customer	N/A
Underground Service Lateral (Residential)	Company	Company
Underground Service Lateral (Commercial) (except WI and MI)	Customer	Customer
Slip Sleeve/Expansion Joint	Customer	Customer
Service Entrance Conduit	Customer	Customer
Meter Socket(s)	Customer	Customer
Meter Socket Mounting Structure	Customer	Customer
Optional Wireway	Customer	Customer
Line Side Conductor Terminations (except WI and MI)	Customer	Customer
Billing Meter(s)	Company	Company
Load Side Conduit(s) And Conductor(s)	Customer	Customer
Ground Rod(s)	Customer	Customer

Point of Delivery:

Underground Service Residential (6 meters or fewer)

- At line side terminals of meter socket; or
- Line side of disconnect if main disconnect is used ahead of metering.

Underground Service Commercial – Point where the *Company's* facilities are first connected to the electric facilities of the customer.

* Note: In TX/NM only, all Overhead to Underground Service Laterals that do not utilize a secondary pedestal will be Company owned. For service laterals extending directly from a pad mounted transformer, residential services will be Company owned while commercial services will be Customer owned unless Customer owned metering cabinet is on the same pad as the transformer. For all installations utilizing a secondary connection cabinet or a secondary pedestal, the Service Lateral will be Customer owned.

DRAWING SC-90

PERMANENT SERVICE INSTALLATION FROM AN UNDERGROUND SECONDARY SUPPLY

Services up to 320 amp 1Ø-3Ø
Residential or Commercial

Installation shall be outside of the utility easement and must be more than 6' from the service pedestal, pull box, or pad-mounted transformer.

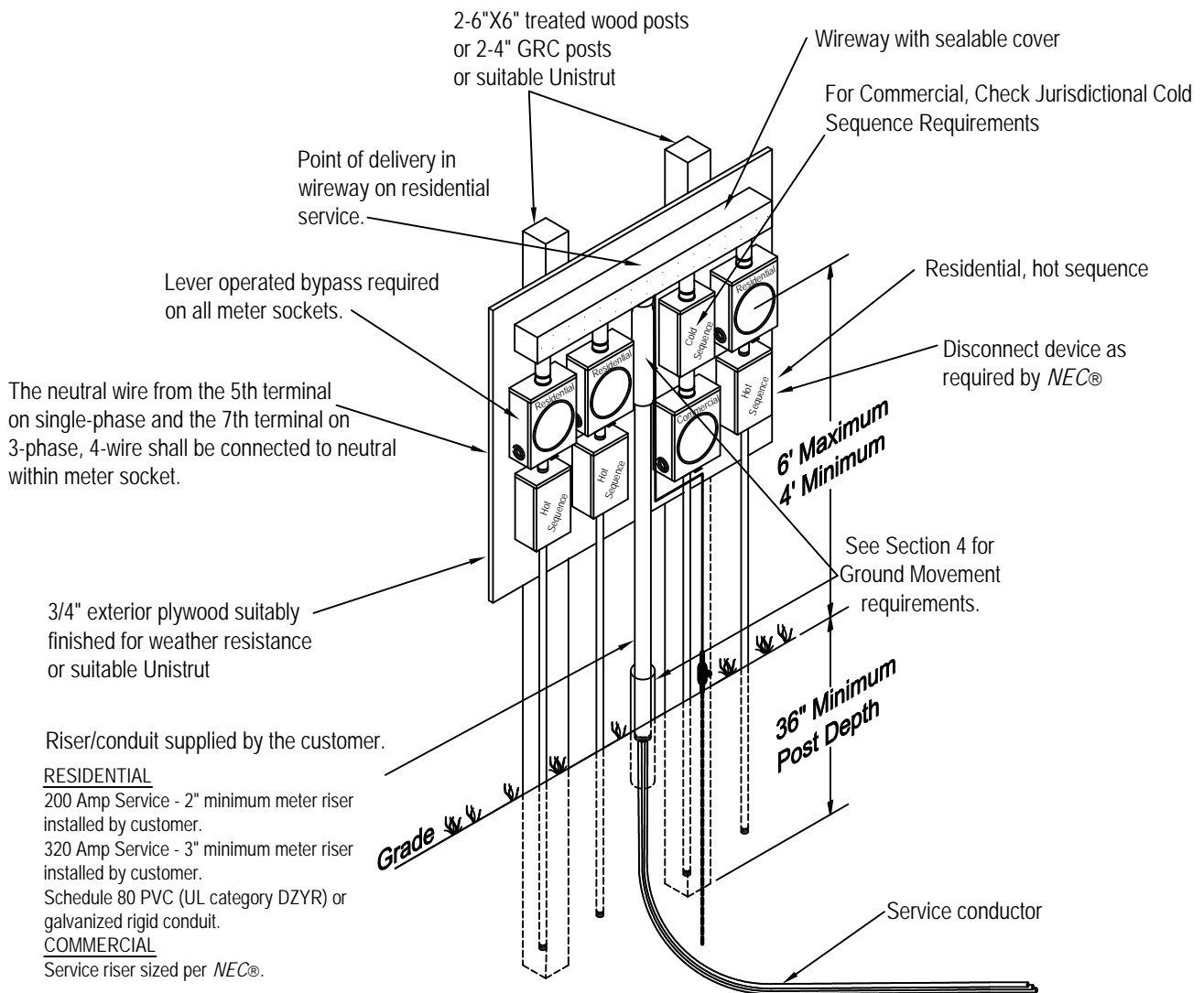

NOTES:

1. Ground rod(s) furnished and installed by the customer per *NEC*®.
2. See [Sections 4.14.3](#), [4.14.4](#), and [4.14.5](#) for meter socket identification requirements.
3. See [Sections 4.17](#) and [4.18](#) for cold and hot sequence metering requirements.

TABLE OF RESPONSIBILITY

Drawing SC-100		
ITEM, MATERIAL OR WORK DESCRIPTION	PARTY TO FURNISH, OWN AND MAINTAIN	PARTY TO INSTALL
Permits and Inspections	Customer	N/A
Overhead Service Drop	<i>Company*</i>	<i>Company*</i>
Underground Service Lateral (6 or fewer Residential)	<i>Company*</i>	<i>Company*</i>
Underground Service Lateral (Commercial) (except WI and MI)	Customer*	Customer*
Service Entrance Conduit	Customer	Customer
Multiple Meter Center	Customer	Customer
Main Disconnect, If Required	Customer	Customer
Billing Meter(s)	<i>Company</i>	<i>Company</i>
Load Side Conduit(s) And Conductor(s)	Customer	Customer
Ground Rod(s)	Customer	Customer

Point of Delivery:

Overhead Service Residential/Commercial – Point where the *Company's* facilities are first connected to the electric facilities of the customer

Underground Service Residential (6 meters or fewer)

- At line side terminals of meter socket; or
- Line side of disconnect if main disconnect is used ahead of metering.

Underground Service Commercial – Point where the *Company's* facilities are first connected to the electric facilities of the customer.

* Note: In TX/NM only, all Overhead to Underground Service Laterals that do not utilize a secondary pedestal will be Company owned. For service laterals extending directly from a pad mounted transformer, residential services will be Company owned while commercial services will be Customer owned unless Customer owned metering cabinet is on the same pad as the transformer. For all installations utilizing a secondary connection cabinet or a secondary pedestal, the Service Lateral will be Customer owned.

DRAWING SC-100

MULTIPLE METERING FROM AN OVERHEAD/UNDERGROUND SECONDARY SUPPLY (PREFERRED METHOD TO DRAWING SC-110)

Services up to 320 amp 1Ø-3Ø
Residential or Commercial

The neutral wire from the 5th terminal on single-phase and the 7th terminal on 3-phase, 4-wire shall be connected to neutral within meter socket.

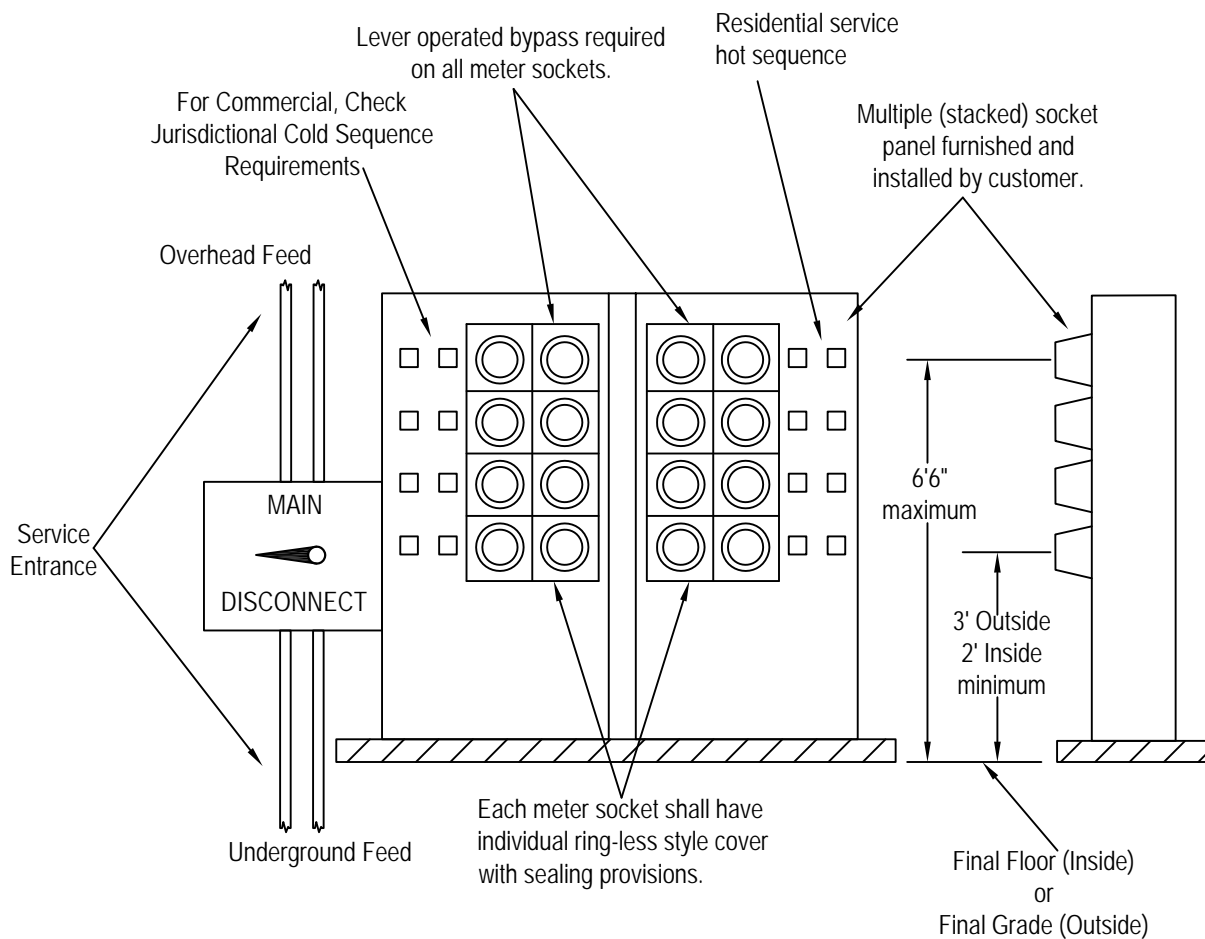

NOTES:

1. See [Sections 4.14.3, 4.14.4, and 4.14.5](#) for meter socket identification requirements.
2. See [Section 4.11](#) for meter socket requirements.
3. See [Section 4.11.2](#) for multiple meter panel requirements.
4. See [Sections 4.17 and 4.18](#) for cold and hot sequence metering requirements.
5. Transformer-rated services can be utilized in multiple metering installations, and they are permitted to have a single main disconnect ahead of the CT compartment.

TABLE OF RESPONSIBILITY

Drawing SC-110		
ITEM, MATERIAL OR WORK DESCRIPTION	PARTY TO FURNISH, OWN AND MAINTAIN	PARTY TO INSTALL
Permits and Inspections	Customer	N/A
Overhead Service Drop	Company*	Company*
Underground Service Lateral (6 or fewer Residential)	Company*	Company*
Underground Service Lateral (Commercial) (except WI and MI)	Customer*	Customer*
Service Entrance Conduit	Customer	Customer
Meter Socket(s)	Customer	Customer
Optional Wireway (Lockable)	Customer	Customer
Billing Meter(s)	Company	Company
Load Side Conduit(s) And Conductor(s)	Customer	Customer
Ground Rod(s)	Customer	Customer

Point of Delivery:

Overhead Service Residential/Commercial – Point where the *Company's* facilities are first connected to the electric facilities of the customer.

Underground Service Residential (6 meters or fewer)

- At line side terminals of meter socket; or
- Line side of disconnect if main disconnect is used ahead of metering.

Underground Service Commercial – Point where the *Company's* facilities are first connected to the electric facilities of the customer.

* Note: In TX/NM only, all Overhead to Underground Service Laterals that do not utilize a secondary pedestal will be Company owned. For service laterals extending directly from a pad mounted transformer, residential services will be Company owned while commercial services will be Customer owned unless Customer owned metering cabinet is on the same pad as the transformer. For all installations utilizing a secondary connection cabinet or a secondary pedestal, the Service Lateral will be Customer owned.

DRAWING SC-110

FABRICATED MULTIPLE METERING FROM AN OVERHEAD/UNDERGROUND SECONDARY SUPPLY (ALTERNATIVE METHOD TO DRAWING SC-100)

Services up to 320 amp 1Ø-3Ø
Residential or Commercial

Lever operated bypass required on all meter sockets.

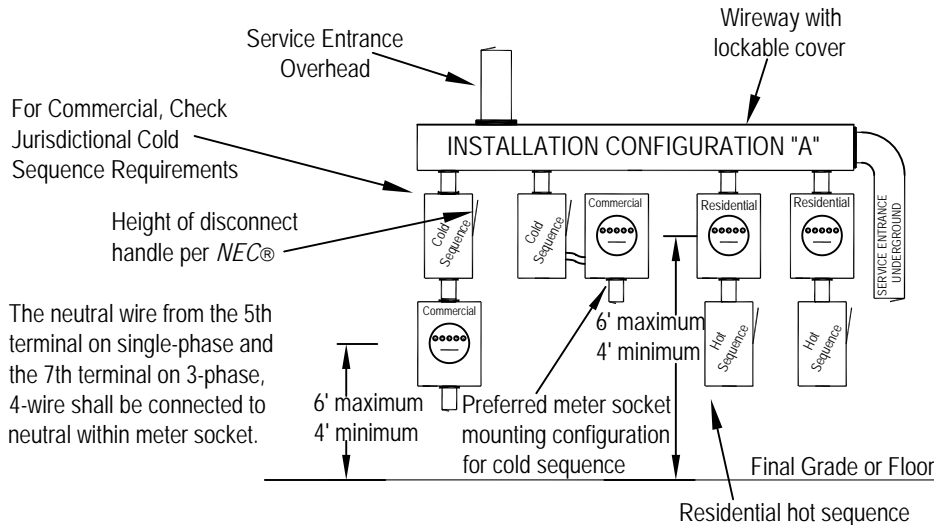

CONFIGURATION "A"

Mounting height of meters shall be at least 4' and no greater than 6' from final grade.

A single bank of meters is the preferred installation configuration.

If space does not allow the single bank installation, then configuration "B" may be used.

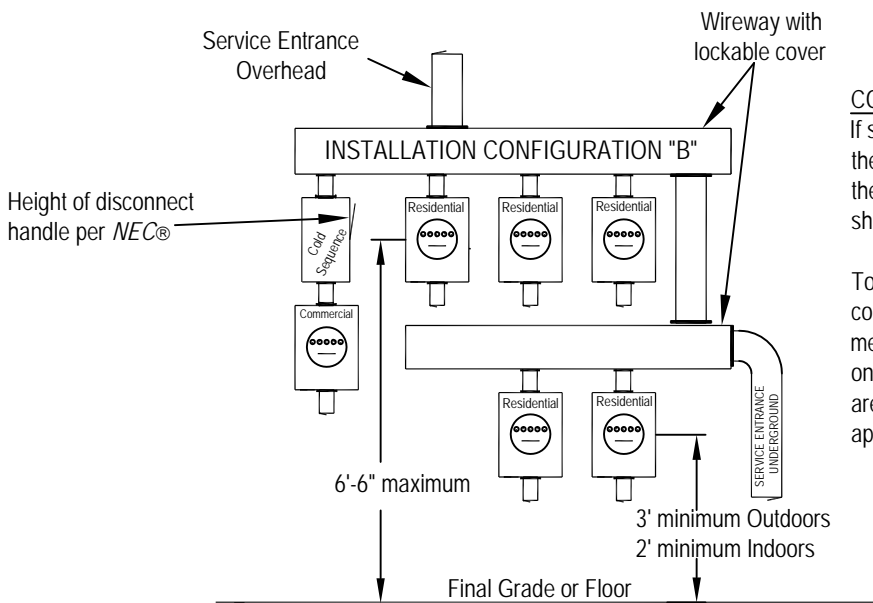

CONFIGURATION "B"

If space does not allow configuration "A", then configuration "B" may be used and these mounting height requirements shall apply.

To apply the meter mounting heights of configuration "B", two or more rows of meter mounting devices must exist. If only one row of meter mounting devices are installed, configuration "A" shall apply.

NOTES:

1. Meter sockets and service equipment are furnished by customer.
2. See [Sections 4.14.3, 4.14.4, and 4.14.5](#) for meter socket identification requirements.
3. See [Sections 4.17 and 4.18](#) for cold and hot sequence metering requirements.
4. Transformer-rated services can be utilized in multiple metering installations, and they are permitted to have a single main disconnect ahead of the CT compartment.

TABLE OF RESPONSIBILITY

Drawing SC-120		
ITEM, MATERIAL OR WORK DESCRIPTION	PARTY TO FURNISH, OWN AND MAINTAIN	PARTY TO INSTALL
Permits and Inspections	Customer	N/A
Overhead Service Drop	<i>Company</i>	<i>Company</i>
Service Entrance Conduit, Conductor, and OH Point of Attachment	Customer	Customer
Meter Socket	Customer	Customer
Billing Meter	<i>Company</i>	<i>Company</i>
Load Side Conduit and Conductor	Customer	Customer
Ground Rod(s)	Customer	Customer

Point of Delivery:

Overhead Service Residential/Commercial – Point where the *Company's* facilities are first connected to the electric facilities of the customer.

DRAWING SC-120

WIRING CONFIGURATION FOR OVERHEAD INSTALLATION

120/208 Volt Wye, 120/240 Volt Delta, or 277/480 Volt Wye 3-Phase 4-Wire

Lever operated bypass required

7th terminal required and shall be connected to the neutral within the meter socket.

High-Leg, Wild Leg, Power Leg Marking

The service entrance conductor intended to be connected to the high-leg of a 3-phase, 4-wire delta-connected system shall be durably and permanently marked at both ends of the conductor by an outer finish that is orange in color and shall be installed in the far right hand position of the meter mounting block.

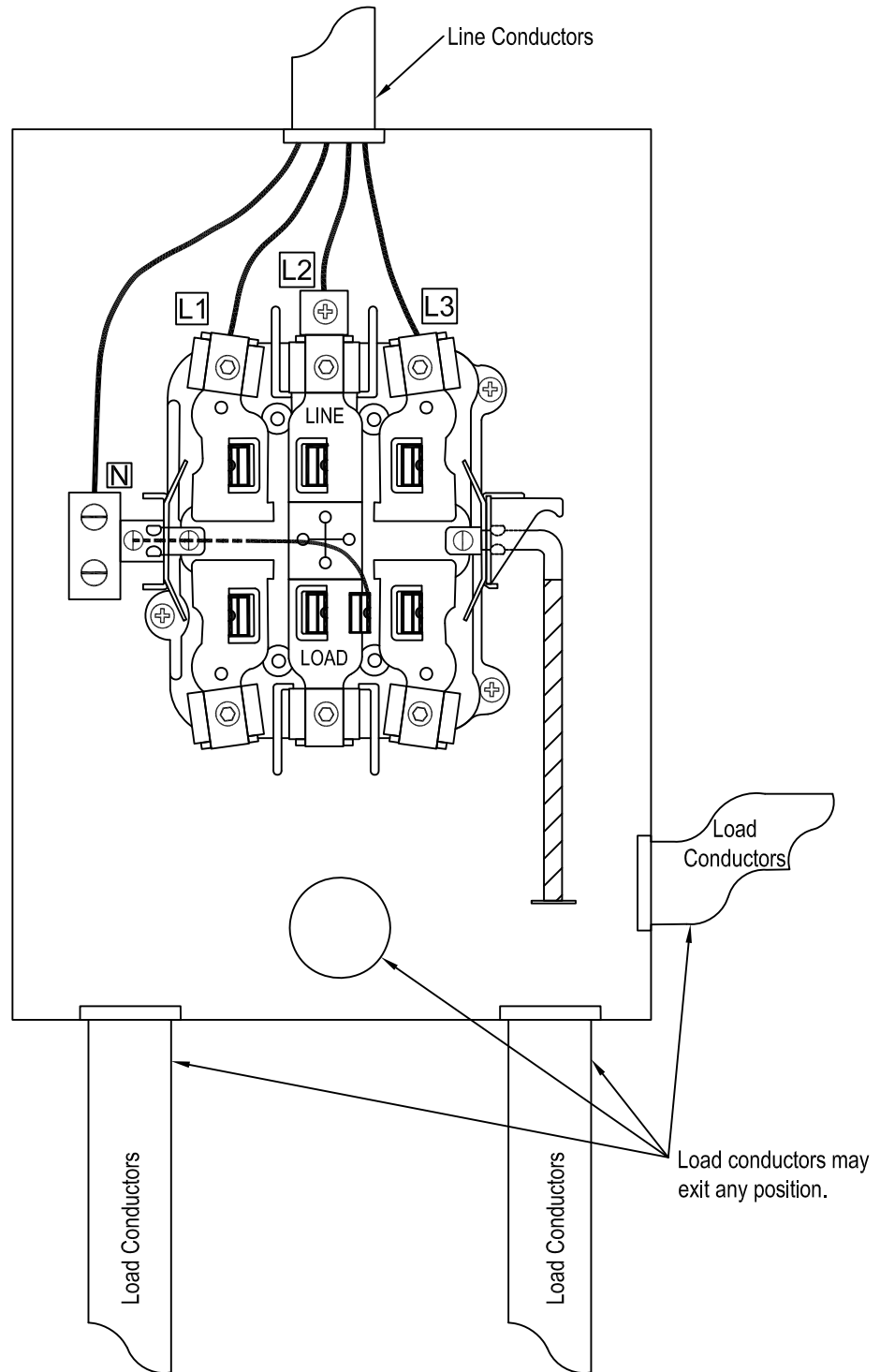
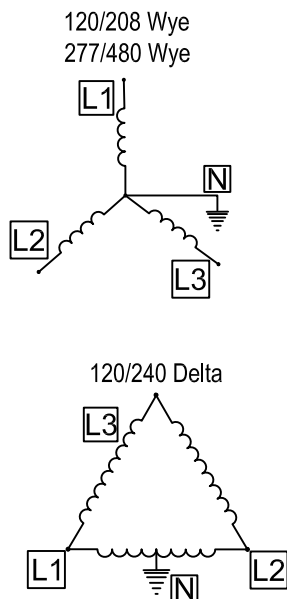

NOTES:

1. See Sections 4.17 and 4.18 for cold and hot sequence metering requirements.
2. Meter housing shall be grounded per NEC®.

TABLE OF RESPONSIBILITY

Drawing SC-130		
ITEM, MATERIAL OR WORK DESCRIPTION	PARTY TO FURNISH, OWN AND MAINTAIN	PARTY TO INSTALL
Permits and Inspections	Customer	N/A
Overhead Service Drop	<i>Company</i>	<i>Company</i>
Service Entrance Conduit, Conductor, and OH Point of Attachment	Customer	Customer
Meter Socket	Customer	Customer
Billing Meter	<i>Company</i>	<i>Company</i>
Load Side Conduit and Conductor	Customer	Customer
Ground Rod(s)	Customer	Customer

Point of Delivery:

Overhead Service Residential/Commercial – Point where the *Company's* facilities are first connected to the electric facilities of the customer.

DRAWING SC-130

WIRING CONFIGURATION FOR OVERHEAD INSTALLATION
 120/208 Volt or 120/240 Volt 1-Phase 3-Wire, 240 Volt Delta
 3-Phase 3-Wire, or 480 Volt Delta 3-Phase 3-Wire

Lever operated bypass required

5th terminal required and shall be connected to the neutral on 1-phase, 3-wire or the grounded phase on 3-phase, 3-wire within the meter socket.

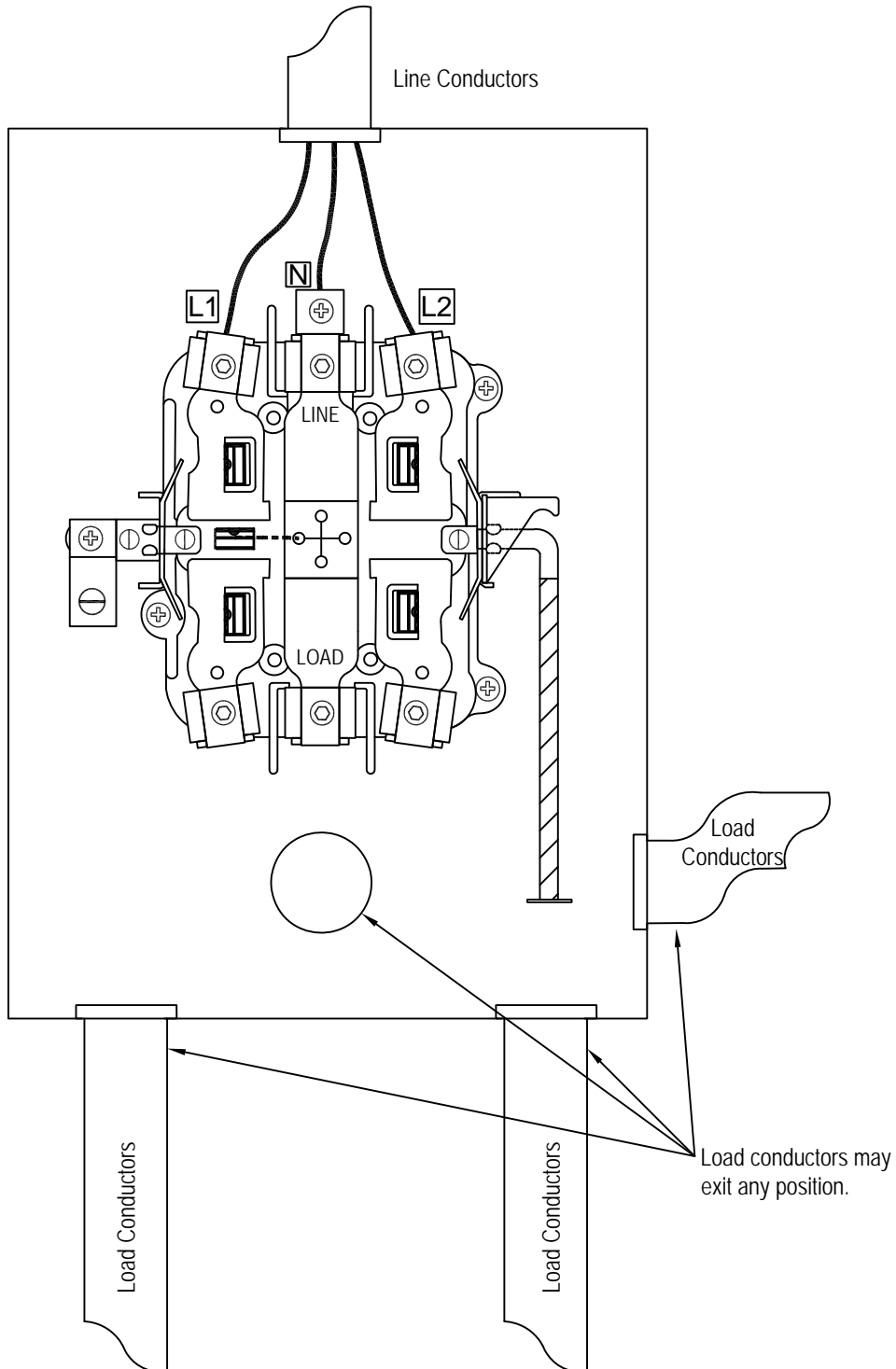
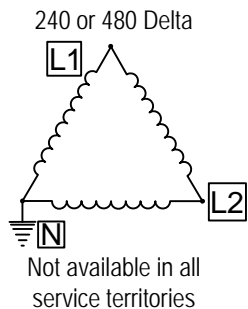
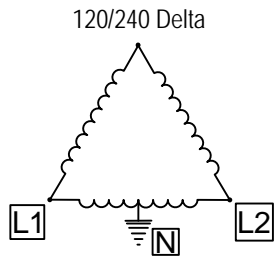
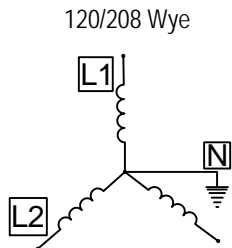
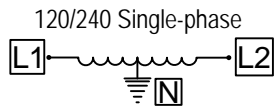

NOTES:

1. See [Sections 4.17](#) and [4.18](#) for cold and hot sequence metering requirements.
2. Meter housing shall be grounded per NEC®.

TABLE OF RESPONSIBILITY

Drawing SC-140		
ITEM, MATERIAL OR WORK DESCRIPTION	PARTY TO FURNISH, OWN AND MAINTAIN	PARTY TO INSTALL
Permits and Inspections	Customer	N/A
Underground Service Lateral (6 or fewer Residential)	Company	Company
Underground Service Lateral (Commercial) (except WI and MI)	Customer	Customer
Service Entrance Conduit	Customer	Customer
Meter Socket	Customer	Customer
Line Side Conductor Terminations (except WI and MI)	Customer	Customer
Billing Meter	Company	Company
Load Side Conduit(s) And Conductor(s)	Customer	Customer
Ground Rod(s)	Customer	Customer

Point of Delivery:

Underground Service Residential (6 meters or fewer)

- At line side terminals of meter socket; or
- Line side of disconnect if main disconnect is used ahead of metering.

Underground Service Commercial – Point where the *Company's* facilities are first connected to the electric facilities of the customer.

* Note: In TX/NM only, all Overhead to Underground Service Laterals that do not utilize a secondary pedestal will be Company owned. For service laterals extending directly from a pad mounted transformer, residential services will be Company owned while commercial services will be Customer owned unless Customer owned metering cabinet is on the same pad as the transformer. For all installations utilizing a secondary connection cabinet or a secondary pedestal, the Service Lateral will be Customer owned.

DRAWING SC-140

WIRING CONFIGURATION FOR UNDERGROUND INSTALLATION 120/208 Volt Wye, 120/240 Volt Delta, or 277/480 Volt Wye 3-Phase 4-Wire

Lever operated bypass required

7th terminal required and shall be connected to the neutral within the meter socket.

High-Leg, Wild Leg, Power Leg Marking
The service entrance conductor intended to be connected to the high-leg of a 3-phase, 4-wire delta-connected system shall be durably and permanently marked at both ends of the conductor by an outer finish that is orange in color and shall be installed in the far right hand position of the meter mounting block.

120/208 Wye
277/480 Wye

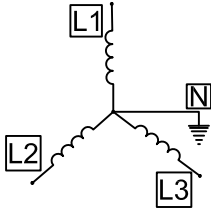

120/240 Delta

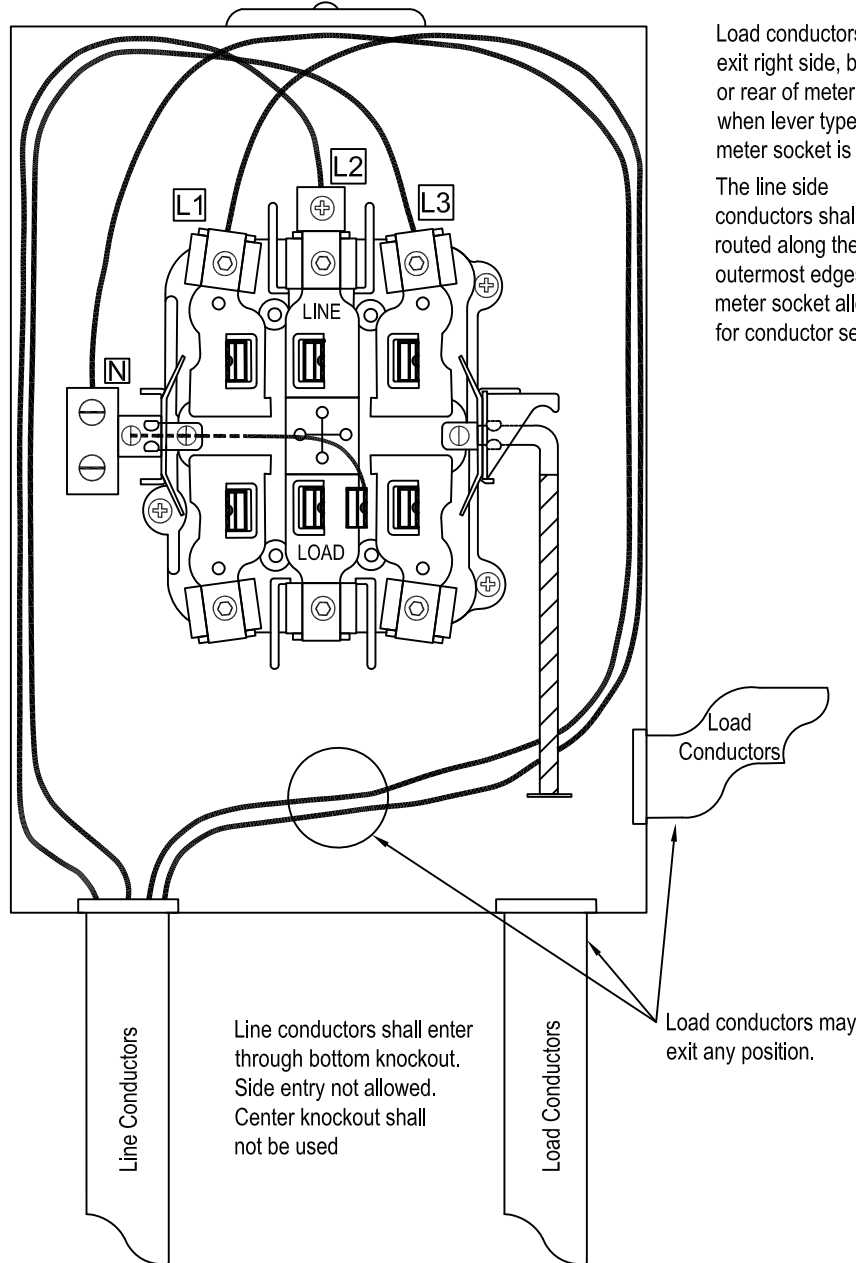
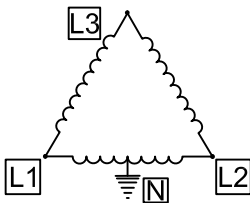

Load conductors shall exit right side, bottom, or rear of meter socket when lever type bypass meter socket is utilized.

The line side conductors shall be routed along the outermost edges of the meter socket allowing for conductor settling.

Line conductors shall enter through bottom knockout. Side entry not allowed. Center knockout shall not be used

Load conductors may exit any position.

NOTES:

1. See Sections 4.17 and 4.18 for cold and hot sequence metering requirements
2. Meter housing shall be grounded per NEC®.

TABLE OF RESPONSIBILITY

Drawing SC-150		
ITEM, MATERIAL OR WORK DESCRIPTION	PARTY TO FURNISH, OWN AND MAINTAIN	PARTY TO INSTALL
Permits and Inspections	Customer	N/A
Underground Service Lateral (6 or fewer Residential)	<i>Company</i>	<i>Company</i>
Underground Service Lateral (Commercial) (except WI and MI)	Customer	Customer
Service Entrance Conduit	Customer	Customer
Meter Socket	Customer	Customer
Line Side Conductor Terminations (except WI and MI)	Customer	Customer
Billing Meter	<i>Company</i>	<i>Company</i>
Load Side Conduit And Conductor	Customer	Customer
Ground Rod(s)	Customer	Customer

Point of Delivery:

Underground Service Residential (6 meters or fewer)

- At line side terminals of meter socket; or
- Line side of disconnect if main disconnect is used ahead of metering.

Underground Service Commercial – Point where the *Company's* facilities are first connected to the electric facilities of the customer.

* Note: In TX/NM only, all Overhead to Underground Service Laterals that do not utilize a secondary pedestal will be Company owned. For service laterals extending directly from a pad mounted transformer, residential services will be Company owned while commercial services will be Customer owned unless Customer owned metering cabinet is on the same pad as the transformer. For all installations utilizing a secondary connection cabinet or a secondary pedestal, the Service Lateral will be Customer owned.

DRAWING SC-150

WIRING CONFIGURATION FOR UNDERGROUND INSTALLATION
 120/208 Volt or 120/240 Volt 1-Phase 3-Wire, 240 Volt Delta 3-Phase 3-Wire,
 or 480 Volt Delta 3-Phase 3-Wire

Lever operated bypass required.

5th terminal required and shall be connected to the neutral on 1-phase, 3-wire or the grounded phase on 3-phase, 3-wire within the meter socket.

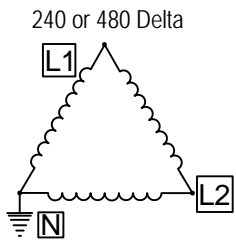
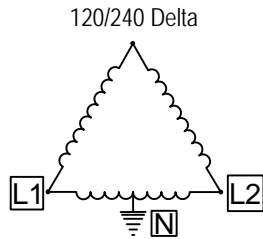
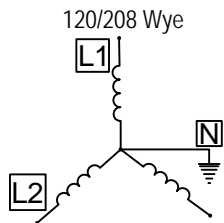
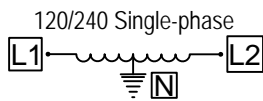

Not available in all service territories

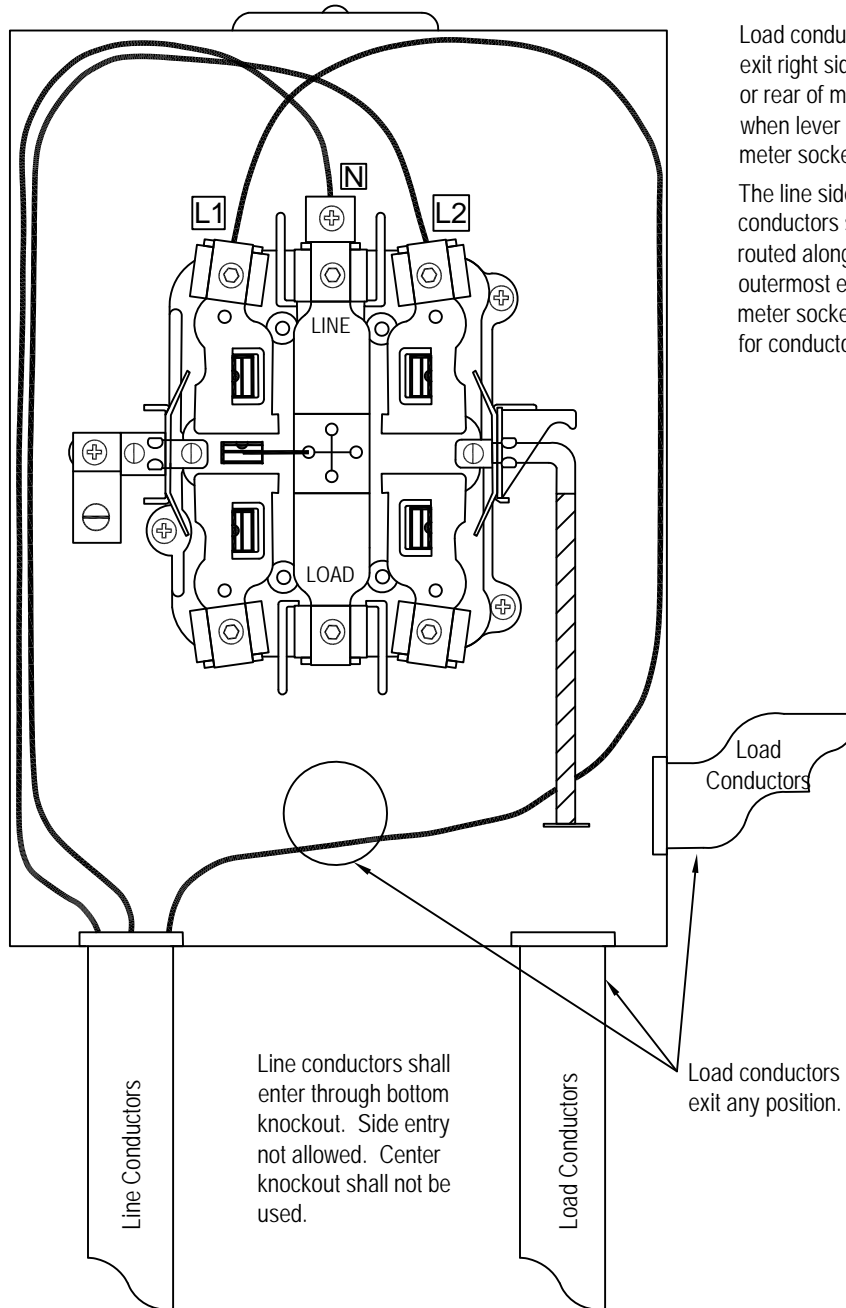

Load conductors shall exit right side, bottom, or rear of meter socket when lever type bypass meter socket is utilized.

The line side conductors shall be routed along the outermost edges of the meter socket allowing for conductor settling.

Line conductors shall enter through bottom knockout. Side entry not allowed. Center knockout shall not be used.

NOTES:

1. See [Sections 4.17](#) and [4.18](#) for cold and hot sequence metering requirements.
2. Meter housing to be grounded per NEC®.

TABLE OF RESPONSIBILITY

Drawing SC-160		
ITEM, MATERIAL OR WORK DESCRIPTION	PARTY TO FURNISH, OWN AND MAINTAIN	PARTY TO INSTALL
Permits and Inspections	Customer	N/A
Overhead Service Drop	<i>Company</i>	<i>Company</i>
Service Entrance Conduit, Conductor, and OH Point of Attachment	Customer	Customer
Meter Socket	Customer	Customer
Billing Meter	<i>Company</i>	<i>Company</i>
Load Side Conduit and Conductor	Customer	Customer
Ground Rod(s)	Customer	Customer

Point of Delivery:

Overhead Service Residential/Commercial – Point where the *Company's* facilities are first connected to the electric facilities of the customer.

DRAWING SC-160

WIRING CONFIGURATION FOR OVERHEAD INSTALLATION 120 V 1-Phase, 2-Wire

Lever operated bypass required

5th terminal required and shall be connected to the neutral on 1-phase, 2-wire within the meter socket.

120/240/480 Single-phase

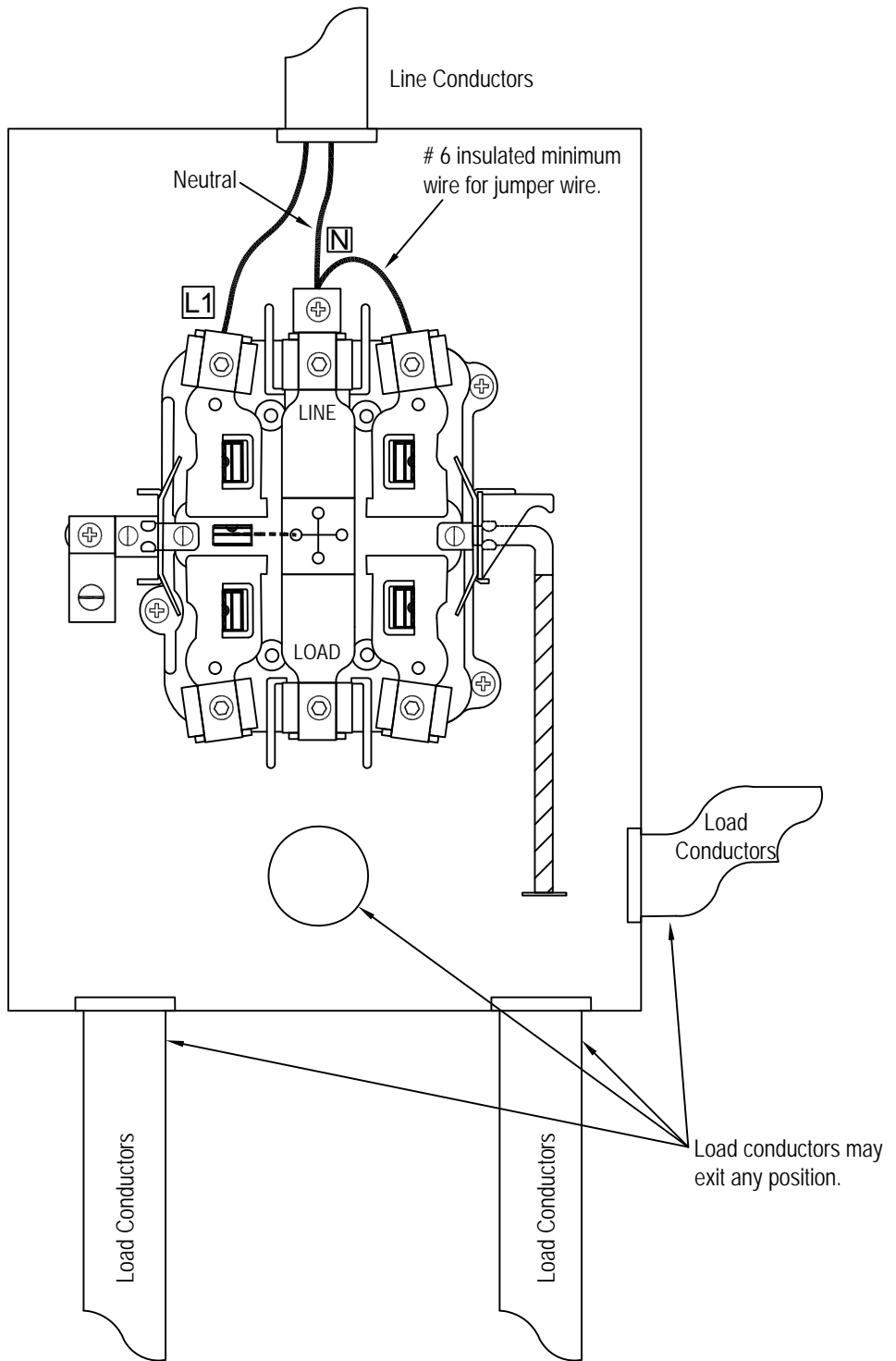
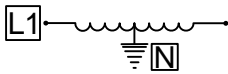

NOTES:

1. See [Sections 4.17](#) and [4.18](#) for cold and hot sequence metering requirements.
2. Meter housing shall be grounded per NEC®.

TABLE OF RESPONSIBILITY

Drawing SC-170		
ITEM, MATERIAL OR WORK DESCRIPTION	PARTY TO FURNISH, OWN AND MAINTAIN	PARTY TO INSTALL
Permits and Inspections	Customer	N/A
Underground Service Lateral (6 or fewer Residential)	Company	Company
Underground Service Lateral (Commercial) (except WI and MI)	Customer	Customer
Service Entrance Conduit	Customer	Customer
Meter Socket	Customer	Customer
Line Side Conductor Terminations (except WI and MI)	Customer	Customer
Billing Meter	Company	Company
Load Side Conduit(s) And Conductor(s)	Customer	Customer
Ground Rod(s)	Customer	Customer

Point of Delivery:

Underground Service Residential (6 meters or fewer)

- At line side terminals of meter socket; or
- Line side of disconnect if main disconnect is used ahead of metering.

Underground Service Commercial – Point where the *Company's* facilities are first connected to the electric facilities of the customer.

* Note: In TX/NM only, all Overhead to Underground Service Laterals that do not utilize a secondary pedestal will be Company owned. For service laterals extending directly from a pad mounted transformer, residential services will be Company owned while commercial services will be Customer owned unless Customer owned metering cabinet is on the same pad as the transformer. For all installations utilizing a secondary connection cabinet or a secondary pedestal, the Service Lateral will be Customer owned.

DRAWING SC-170

WIRING CONFIGURATION FOR UNDERGROUND INSTALLATION 120 Volt 1-Phase, 2-Wire

Lever operated bypass required.

5th terminal required and shall be connected to the neutral on 1-phase, 2-wire within the meter socket.

120/240/480 Single-phase

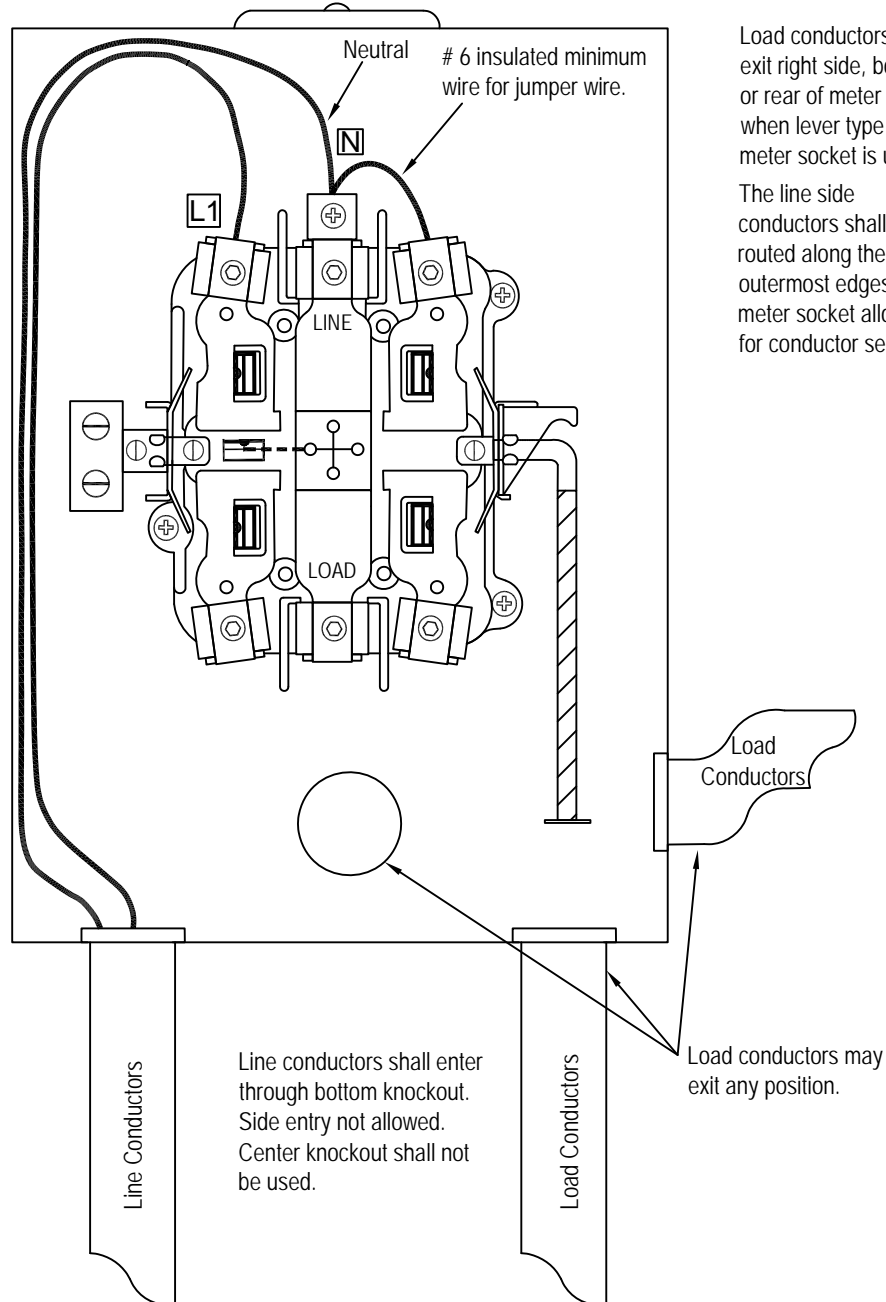

Load conductors shall exit right side, bottom, or rear of meter socket when lever type bypass meter socket is utilized.

The line side conductors shall be routed along the outermost edges of the meter socket allowing for conductor settling.

Load conductors may exit any position.

Line conductors shall enter through bottom knockout. Side entry not allowed. Center knockout shall not be used.

NOTES:

1. See [Sections 4.17](#) and [4.18](#) for cold and hot sequence metering requirements
2. Meter housing shall be grounded per NEC®.

TABLE OF RESPONSIBILITY

Drawing TR-10		
ITEM, MATERIAL OR WORK DESCRIPTION	PARTY TO FURNISH, OWN AND MAINTAIN	PARTY TO INSTALL
Permits and Inspections	Customer	N/A
Meter Mounting Structure, Pole	Customer	Customer
Overhead Service Drop	Company*	Company*
Underground Service Lateral (Residential)	Company*	Company*
Underground Service Lateral (Commercial) (except WI and MI)	Customer*	Customer*
Service Entrance Conduit and OH Point of Attachment	Customer	Customer
Current Transformer Enclosure	Customer	Customer
Metering Circuit Conduit	Customer	Customer
Metering Circuit Conductors	Company	Company
Current Transformers	Company	Customer
Meter Socket	Company	Customer
Billing Meter	Company	Company
Load Side Conduit and Conductor	Customer	Customer
Ground Rod(s)	Customer	Customer

Point of Delivery:

Overhead Service Residential/Commercial – Point where the *Company's* facilities are first connected to the electric facilities of the customer.

Underground Service Residential – At line side terminals of CT Cabinet

Underground Service Commercial – Point where the *Company's* facilities are first connected to the electric facilities of the customer.

* Note: In TX/NM only, all Overhead to Underground Service Laterals that do not utilize a secondary pedestal will be Company owned. For service laterals extending directly from a pad mounted transformer, residential services will be Company owned while commercial services will be Customer owned unless Customer owned metering cabinet is on the same pad as the transformer. For all installations utilizing a secondary connection cabinet or a secondary pedestal, the Service Lateral will be Customer owned.

DRAWING TR-10

CURRENT TRANSFORMER INSTALLATION FROM AN OVERHEAD/UNDERGROUND SECONDARY SUPPLY Services Over 400 amp 1Ø-3Ø Residential or Commercial

Installation shall be outside of the utility easement and shall be more than 6' from the service pedestal, pull box or pad-mounted transformer.

Meter pole furnished, installed and owned by customer
Utility Pole Designation = Class 7 minimum or Class 6
Pole Height = 25' Minimum
Pole Strength = 1200 ft-lb minimum 5'-6" embedded per CR-110
Circumference = at ground line 23.5", at pole top 15"
Pole must be treated to prevent ground line decay.

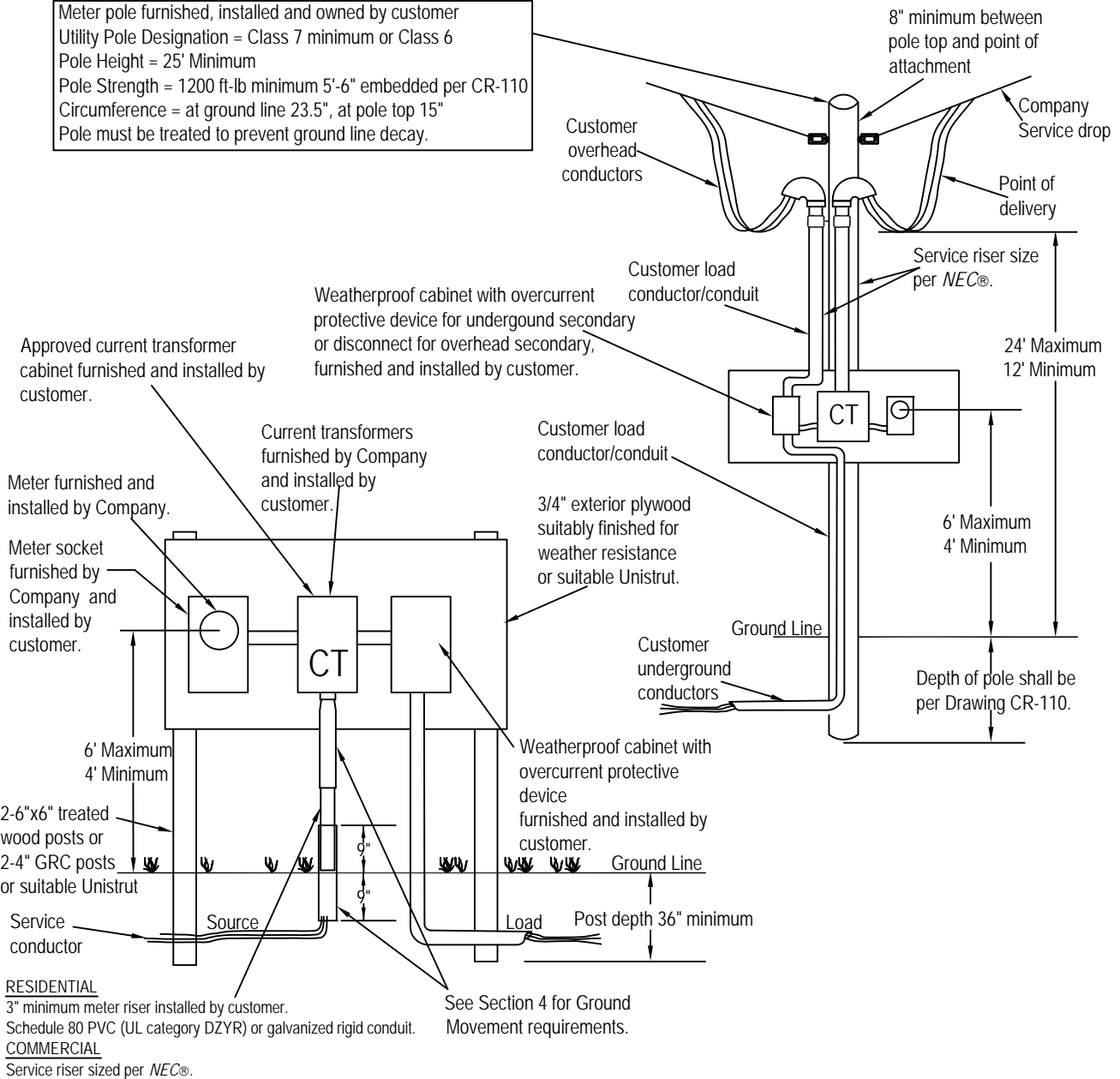

NOTE:

1. See [Section 4.12](#) for current transformer metering requirements.

TABLE OF RESPONSIBILITY

Drawing TR-20 & 20A		
ITEM, MATERIAL OR WORK DESCRIPTION	PARTY TO FURNISH, OWN AND MAINTAIN	PARTY TO INSTALL
Permits and Inspections	Customer	N/A
Overhead Service Drop	<i>Company*</i>	<i>Company*</i>
Underground Service Lateral (Residential)	<i>Company*</i>	<i>Company*</i>
Underground Service Lateral (Commercial) (except WI and MI)	Customer*	Customer*
Service Entrance Conduit	Customer	Customer
Current Transformer Enclosure	Customer	Customer
Metering Circuit Conduit	Customer	Customer
Metering Circuit Conductors	<i>Company</i>	<i>Company</i>
Current Transformers	<i>Company</i>	Customer
Meter Socket	<i>Company</i>	Customer
Billing Meter	<i>Company</i>	<i>Company</i>
Load Side Conduit and Conductor	Customer	Customer
Ground Rod(s)	Customer	Customer

Point of Delivery:

Overhead Service Residential/Commercial – Point where the *Company's* facilities are first connected to the electric facilities of the customer.

Underground Service Residential – At line side terminals of CT Cabinet

Underground Service Commercial – Point where the *Company's* facilities are first connected to the electric facilities of the customer.

* Note: In TX/NM only, all Overhead to Underground Service Laterals that do not utilize a secondary pedestal will be Company owned. For service laterals extending directly from a pad mounted transformer, residential services will be Company owned while commercial services will be Customer owned unless Customer owned metering cabinet is on the same pad as the transformer. For all installations utilizing a secondary connection cabinet or a secondary pedestal, the Service Lateral will be Customer owned.

DRAWING TR-20

CURRENT TRANSFORMER ENCLOSURES Services from 400-800 amps

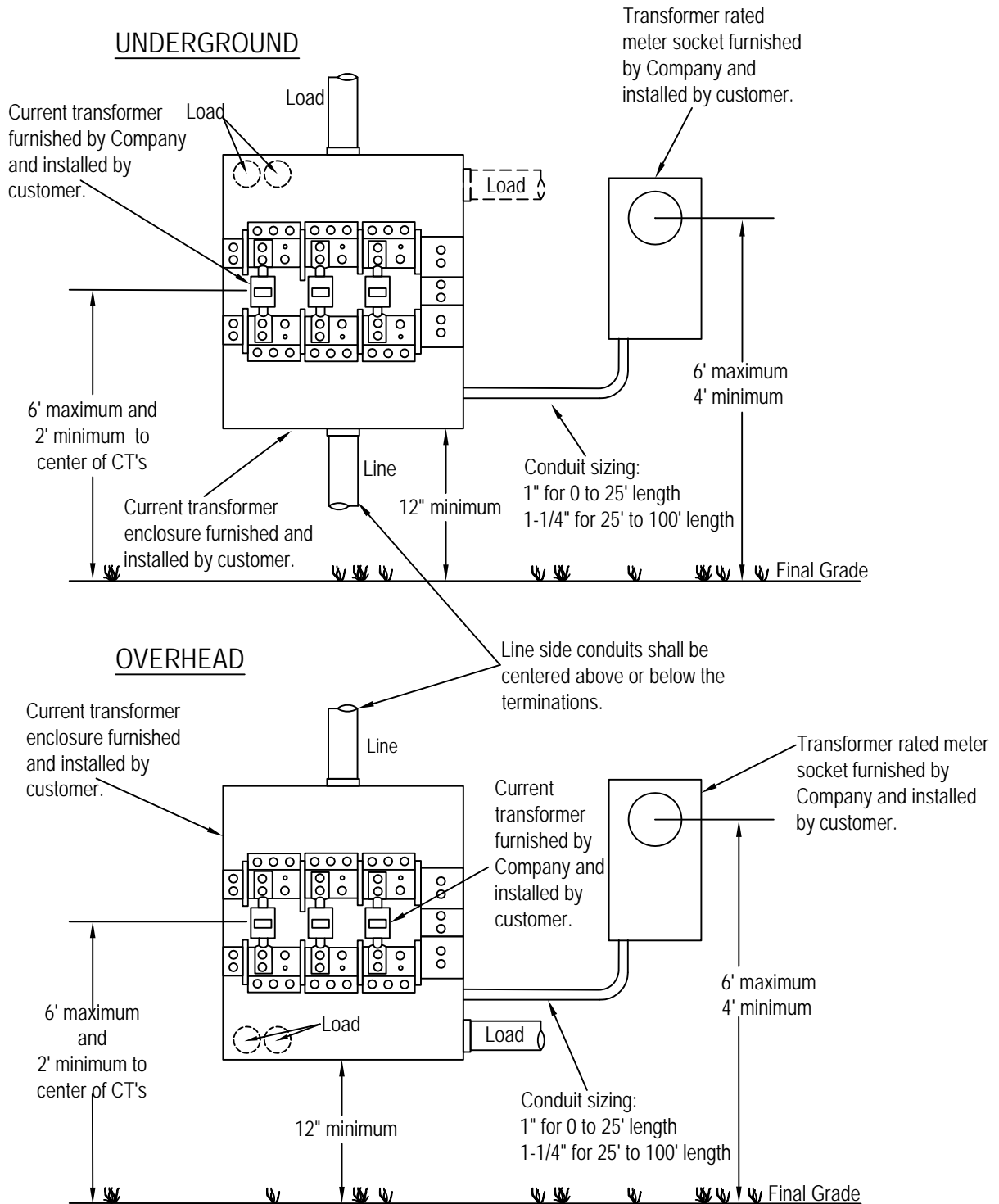

NOTES:

1. Service conductors are not allowed to cross in front of CTs.
2. See [Section 4.12](#) for instrument transformer type, installation details, and requirements.
3. For underground services, the load-side conductors shall terminate and exit in the top half of the CT cabinet for WI and MI.
4. For overhead services, the load-side conductors shall terminate and exit in the bottom half of the CT cabinet for WI and MI.

DRAWING TR-20A

CURRENT TRANSFORMER ENCLOSURES

Services from 801-4000 amps

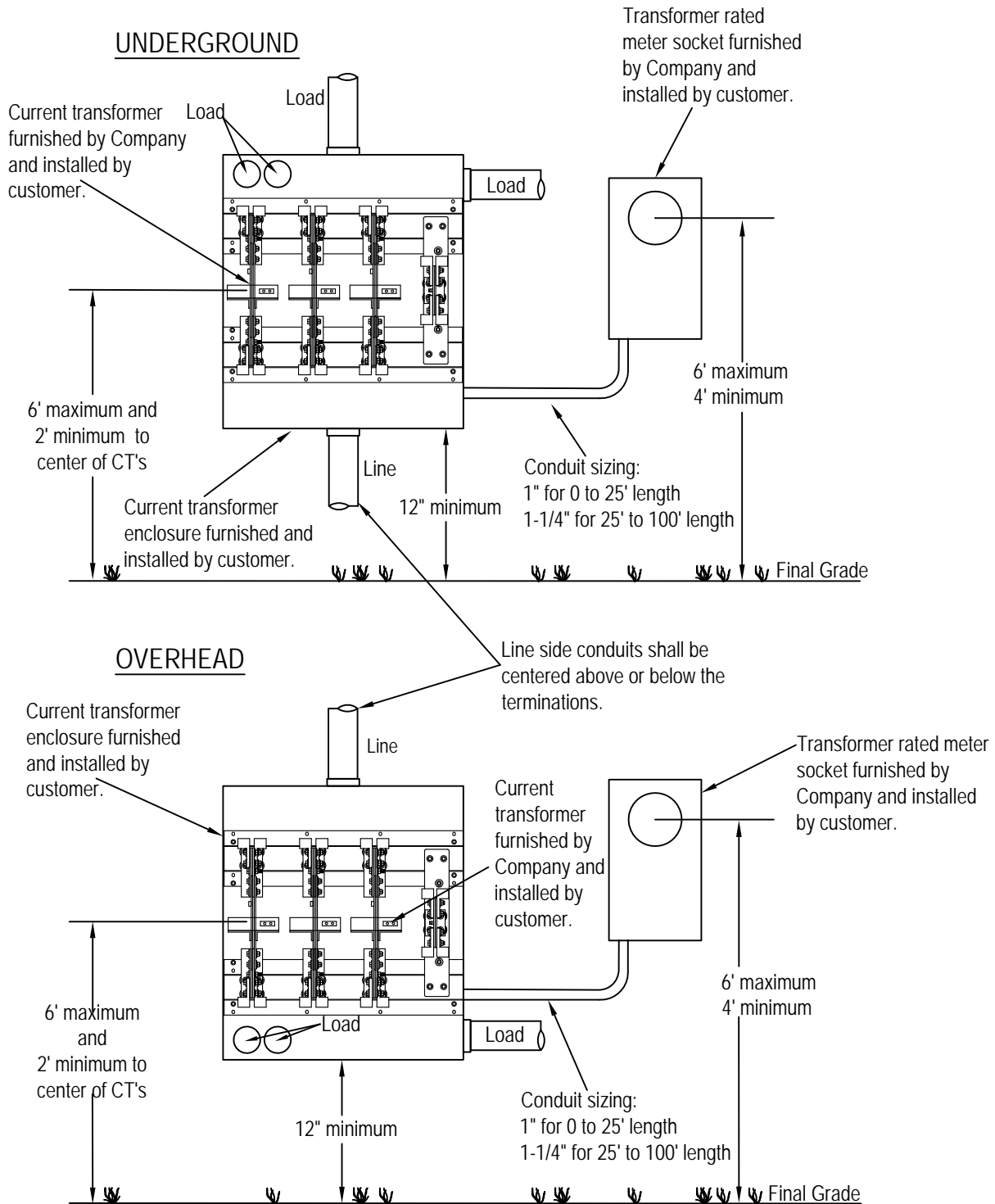

NOTES:

1. Service conductors are not allowed to cross in front of CTs.
2. See [Section 4.12](#) for instrument transformer type, installation details, and requirements.
3. For underground services, the load-side conductors shall terminate and exit in the top half of the CT cabinet for WI and MI.
4. For overhead services, the load-side conductors shall terminate and exit in the bottom half of the CT cabinet for WI and MI.

This Page Intentionally Left Blank

TABLE OF RESPONSIBILITY

Drawing TR-30		
ITEM, MATERIAL OR WORK DESCRIPTION	PARTY TO FURNISH, OWN AND MAINTAIN	PARTY TO INSTALL
Permits and Inspections	Customer	N/A
Overhead Service Drop	Company*	Company*
Underground Service Lateral (Residential)	Company*	Company*
Underground Service Lateral (Commercial) (except WI and MI)	Customer*	Customer*
Service Entrance Conduit	Customer	Customer
Switchgear with Current Transformer Compartment	Customer	Customer
Metering Circuit Conduit	Customer	Customer
Metering Circuit Conductors	Company	Company
Current Transformers	Company	Customer
Meter Socket	Company	Customer
Billing Meter	Company	Company
Load Side Conduit and Conductor	Customer	Customer
Ground Rod(s)	Customer	Customer

Point of Delivery:

Overhead Service Commercial – Point where the *Company's* facilities are first connected to the electric facilities of the customer.

Underground Service Commercial – Point where the *Company's* facilities are first connected to the electric facilities of the customer.

* Note: In TX/NM only, all Overhead to Underground Service Laterals that do not utilize a secondary pedestal will be Company owned. For service laterals extending directly from a pad mounted transformer, residential services will be Company owned while commercial services will be Customer owned unless Customer owned metering cabinet is on the same pad as the transformer. For all installations utilizing a secondary connection cabinet or a secondary pedestal, the Service Lateral will be Customer owned.

DRAWING TR-30

TYPICAL ARRANGEMENTS FOR C.T. COMPARTMENTS WITHIN CUSTOMER OWNED GEAR

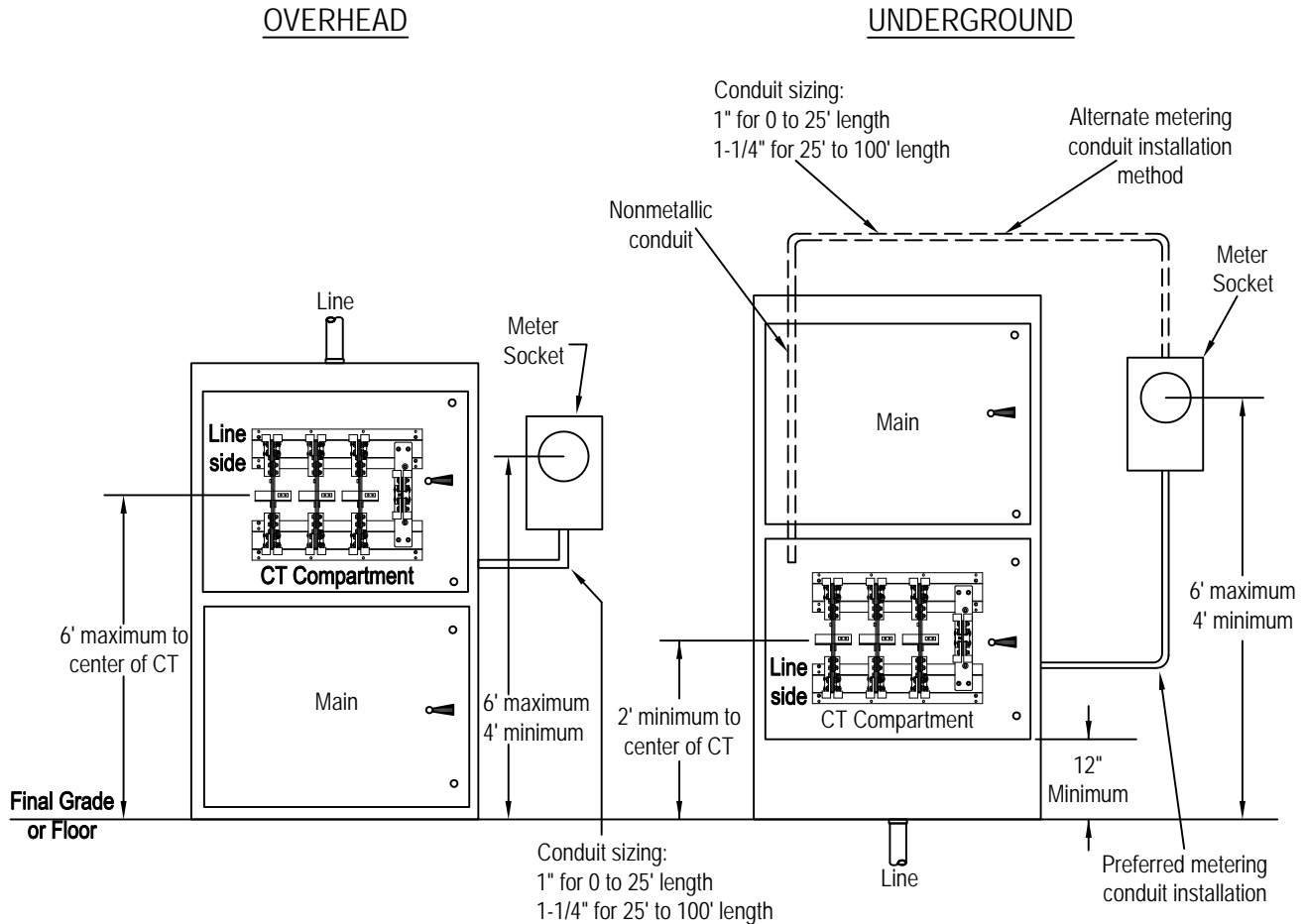

SEE DRAWING TR-40 FOR CURRENT TRANSFORMER MOUNTING REQUIREMENTS

NOTES:

1. All cabinets shall be UL approved.
2. CT compartment shall be locked separately by company.
3. Nonmetallic conduit shall extend into CT compartment.
4. Line side bus bar hole pattern shall have NEMA 2-hole spacing and be centered on bar in WI and MI only.
5. Holes to accommodate 1/2 inch bolts.
6. See [Section 4.12](#) for Current Transformer Cabinet requirements

TABLE OF RESPONSIBILITY

Drawing TR-40		
ITEM, MATERIAL OR WORK DESCRIPTION	PARTY TO FURNISH, OWN AND MAINTAIN	PARTY TO INSTALL
Permits and Inspections	Customer	N/A
Overhead Service Drop	Company*	Company*
Underground Service Lateral (Residential)	Company*	Company*
Underground Service Lateral (Commercial) (except WI and MI)	Customer*	Customer*
Service Entrance Conduit	Customer	Customer
Switchgear with Current Transformer Compartment	Customer	Customer
Metering Circuit Conduit	Customer	Customer
Metering Circuit Conductors	Company	Company
Current Transformers	Company	Customer
Meter Socket	Company	Customer
Billing Meter	Company	Company
Load Side Conduit and Conductor	Customer	Customer
Ground Rod(s)	Customer	Customer

Point of Delivery:

Overhead Service Commercial – Point where the *Company's* facilities are first connected to the electric facilities of the customer.

Underground Service Commercial – Point where the *Company's* facilities are first connected to the electric facilities of the customer.

* Note: In TX/NM only, all Overhead to Underground Service Laterals that do not utilize a secondary pedestal will be Company owned. For service laterals extending directly from a pad mounted transformer, residential services will be Company owned while commercial services will be Customer owned unless Customer owned metering cabinet is on the same pad as the transformer. For all installations utilizing a secondary connection cabinet or a secondary pedestal, the Service Lateral will be Customer owned.

DRAWING TR-40

CURRENT TRANSFORMER MOUNTING REQUIREMENTS FOR CABINETS AND SWITCHGEAR

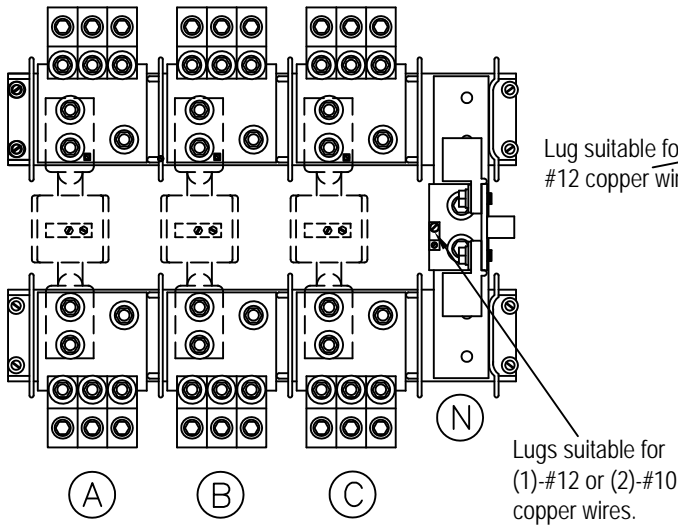
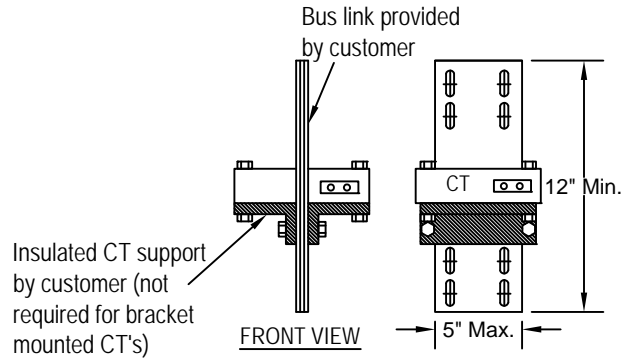
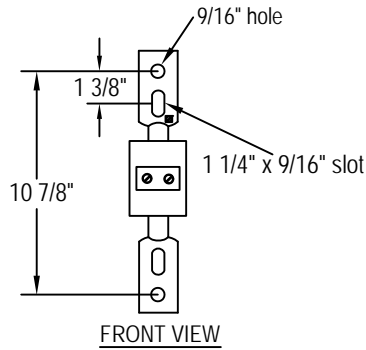

For services 400-800 Amps

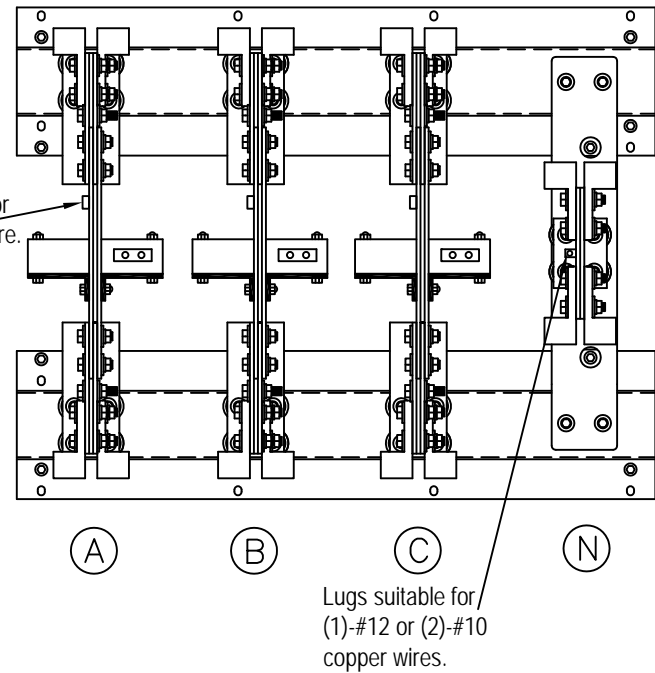

For services 801 - 4000 amps

NOTES:

1. White dot on CT is polarity mark and faces line-side.
2. See [Section 4.12](#) for current transformer cabinet requirements.
3. Line side bus bar hole pattern shall have NEMA 2-hole spacing and be centered on bar in WI and MI only.

TABLE OF RESPONSIBILITY

Drawing PM-10		
ITEM, MATERIAL OR WORK DESCRIPTION	PARTY TO FURNISH, OWN AND MAINTAIN	PARTY TO INSTALL
Permits and Inspections	Customer	N/A
Overhead Primary Line Side	<i>Company</i>	<i>Company</i>
Line Side Deadends, Cutouts, and Arrestors	<i>Company</i>	<i>Company</i>
Metering Pole and Line Side Down Guy, if Required	<i>Company</i>	<i>Company</i>
Instrument Transformers	<i>Company</i>	<i>Company</i>
Instrument Transformer Rack	<i>Company</i>	<i>Company</i>
Meter Socket	<i>Company</i>	<i>Company</i>
Metering Circuit Conduit and Conductors	<i>Company</i>	<i>Company</i>
Billing Meter	<i>Company</i>	<i>Company</i>
Load Side Deadends and Conductors	Customer	Customer
Load Side Connections, Insulators, and Jumpers	<i>Company</i>	<i>Company</i>
Ground Rod(s), Conductor or Grid	<i>Company</i>	<i>Company</i>

Point of Delivery:

Overhead Service Commercial – Point where the *Company's* facilities are first connected to the electric facilities of the customer.

DRAWING PM-10

COMPANY OWNED OVERHEAD PRIMARY METER INSTALLATION

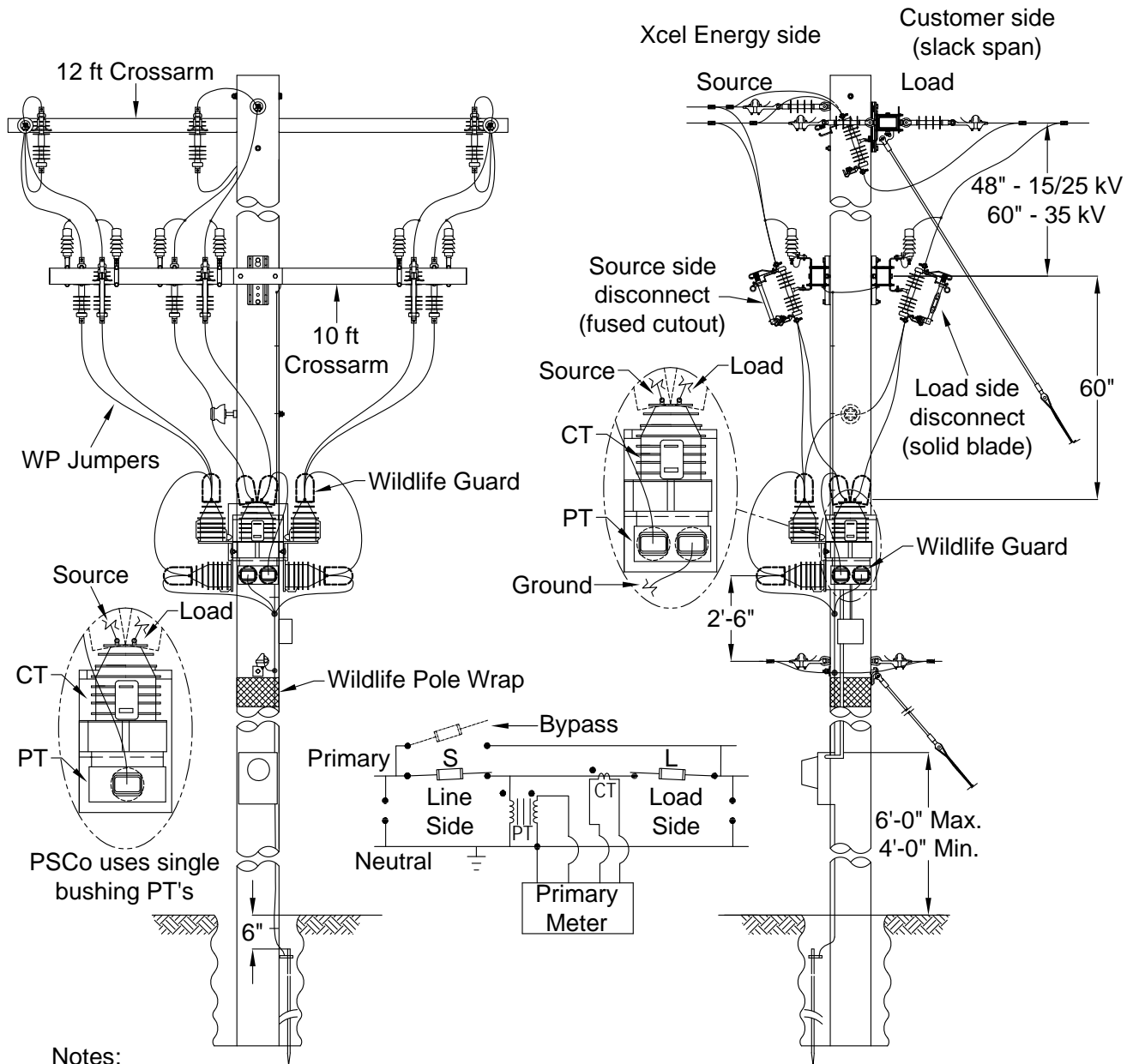

Notes:

1. Customer facilities not allowed on Company primary meter pole.
2. Customer shall provide a pole near primary meter pole for customer switches, fuses, and overhead or underground distribution.
3. The length of the slack span shall normally be 40 ft maximum, but in some instances may be limited to 25 ft. Contact the Area Engineer for specifications.
4. For 4-wire, 3-phase service underground customers are to be served from a separate customer owned terminal pole. Underground does not attach to this pole.
5. Source side cutout and bypass are 100 A fused cutout. The Load side is a 300 A solid blade disconnect.
6. If load exceeds 200 A, consult Area Engineer for switches and protection.
7. Do not hang fuse door for fused bypass on structure.
8. Cutout connectors can accommodate 4/0 copper when larger size copper jumpers are used. If 900 A switches are used, 750 copper or smaller can be used as jumpers.

TABLE OF RESPONSIBILITY

Drawing PM-20		
ITEM, MATERIAL OR WORK DESCRIPTION	PARTY TO FURNISH, OWN AND MAINTAIN	PARTY TO INSTALL
Permits and Inspections	Customer	N/A
Underground Primary Line Side & Termination	<i>Company</i>	<i>Company</i>
Line Side Conduit & Conductors	<i>Company</i>	<i>Company</i>
Protective Equipment and Enclosures	Customer	Customer
Switchgear with Metering Compartment	Customer	Customer
Instrument Transformers	<i>Company</i>	Customer
Meter Socket	<i>Company</i>	Customer
Metering Circuit Conduit	Customer	Customer
Metering Circuit Conductors	<i>Company</i>	<i>Company</i>
Billing Meter	<i>Company</i>	<i>Company</i>
Load Side Conduit and Conductors	Customer	Customer
Ground Rod(s), Conductor or Grid	Customer	Customer

Point of Delivery:

Underground Service Commercial – Point where the *Company's* facilities are first connected to the electric facilities of the customer.

For responsibilities of primary line side conduit and conductors in each service area, please contact *Company* for information.

DRAWING PM-20

CUSTOMER-OWNED PRIMARY SWITCHGEAR

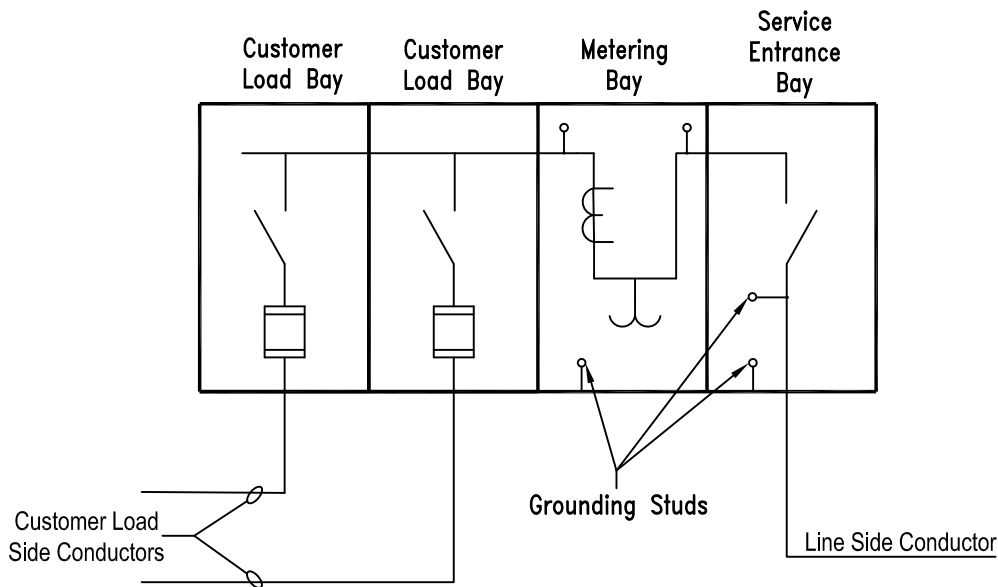

Load conductors may not pass through metering bay or service entrance bay.

PRIOR TO PURCHASE OF SWITCH GEAR, WORKING DRAWINGS OF THE METERING BAY SHALL BE APPROVED BY METER ENGINEERING DEPARTMENT

APPROVAL OF ALL SWITCHGEAR DRAWINGS, BY LOCAL AREA ENGINEERING DEPARTMENT IS REQUIRED PRIOR TO PURCHASE

CONTACT METER ENGINEERING DEPARTMENT, FOR INSTRUMENT TRANSFORMER MOUNTING AND INSTALLATION REQUIREMENTS.

NOTES:

1. Company will furnish and install incoming service conductors, including terminations.
2. Company will furnish and install meters and secondary conductors for meters.
3. Company will furnish and customer shall install metering current and potential transformers.
4. Company will furnish and customer shall install meter socket.
5. Customer will furnish and install all switchgear, protection equipment, and enclosures.
6. See [Section 4.13](#), Primary Meter Installations, for installation details and requirements.
7. Provide safety barriers between energized equipment and personnel or ground.
8. Meter location to be determined by Electric Meter Department.

TABLE OF RESPONSIBILITY

Drawing PM-30		
ITEM, MATERIAL OR WORK DESCRIPTION	PARTY TO FURNISH, OWN AND MAINTAIN	PARTY TO INSTALL
Permits and Inspections	Customer	N/A
Underground Primary Line Side & Termination	<i>Company</i>	<i>Company</i>
Line Side Conduit & Conductors	<i>Company</i>	<i>Company</i>
Protective Equipment and Enclosures	Customer	Customer
Switchgear with Metering Compartment	Customer	Customer
Instrument Transformers	<i>Company</i>	Customer
Meter Socket	<i>Company</i>	Customer
Metering Circuit Conduit	Customer	Customer
Metering Circuit Conductors	<i>Company</i>	<i>Company</i>
Billing Meter	<i>Company</i>	<i>Company</i>
Load Side Conduit and Conductors	Customer	Customer
Ground Rod(s), Conductor or Grid	Customer	Customer

Point of Delivery:

Underground Service Commercial – Point where the *Company's* facilities are first connected to the electric facilities of the customer.

For responsibilities of primary line side conduit and conductors in each service area, please contact *Company* for information.

DRAWING PM-30

CUSTOMER-OWNED PRIMARY SWITCHGEAR SOURCE SELECTIVE SYSTEM WITH SPLIT BUS

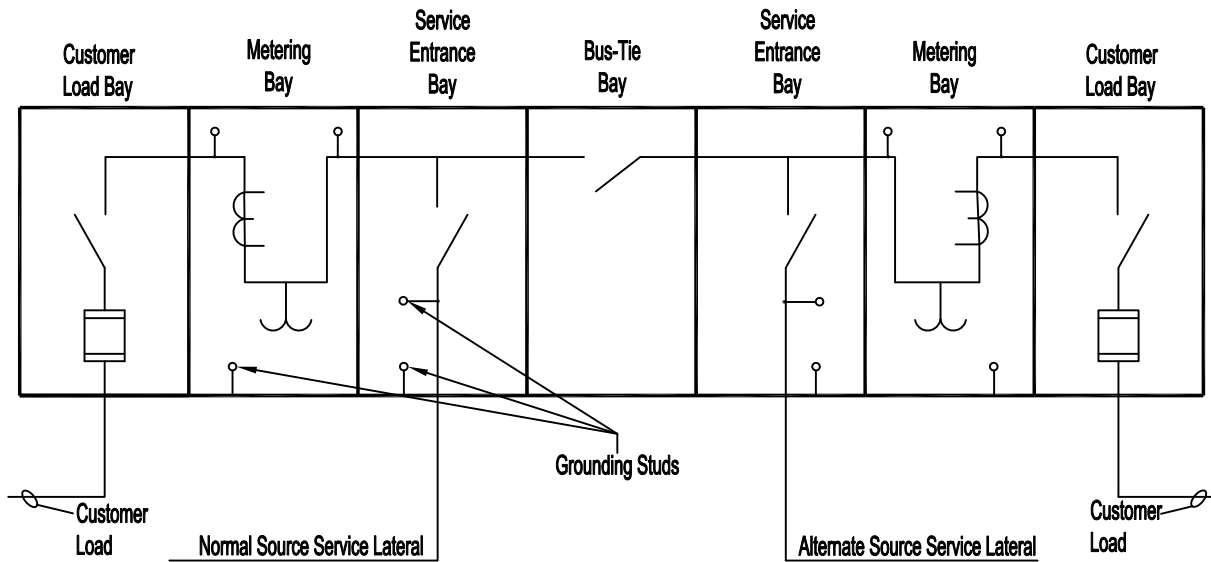

Load conductors may not pass through metering bay or service entrance bay.

PRIOR TO PURCHASE OF SWITCH GEAR, WORKING DRAWINGS OF THE METERING BAY SHALL BE APPROVED BY METER ENGINEERING DEPARTMENT

APPROVAL OF ALL SWITCHGEAR DRAWINGS, BY LOCAL AREA ENGINEERING DEPARTMENT IS REQUIRED PRIOR TO PURCHASE

CONTACT METER ENGINEERING DEPARTMENT, FOR INSTRUMENT TRANSFORMER MOUNTING AND INSTALLATION REQUIREMENTS.

NOTES:

1. Company will furnish and install incoming service conductors, including terminations.
2. Company will furnish and install meters and secondary conductors for meters.
3. Company will furnish and customer shall install metering current and potential transformers.
4. Company will furnish and customer shall install meter socket.
5. Customer will furnish and install all switchgear, protection equipment, and enclosures.
6. See [Section 4.13](#), Primary Meter Installations, for installation details and requirements.
7. Provide safety barriers between energized equipment and personnel or ground.
8. Meter location to be determined by Electric Meter Department.

TABLE OF RESPONSIBILITY

Drawing PM-40		
ITEM, MATERIAL OR WORK DESCRIPTION	PARTY TO FURNISH, OWN AND MAINTAIN	PARTY TO INSTALL
Permits and Inspections	Customer	N/A
Primary Metering Cabinet	<i>Company</i>	<i>Company</i>
Pad, Concrete Pre-cast with Pit	<i>Company</i>	<i>Company</i>
Line Side Conduit and Conductor	<i>Company</i>	<i>Company</i>
Line Side Terminations	<i>Company</i>	<i>Company</i>
Instrument Transformers	<i>Company</i>	<i>Company</i>
Meter Socket	<i>Company</i>	<i>Company</i>
Metering Circuit Conductors	<i>Company</i>	<i>Company</i>
Billing Meter	<i>Company</i>	<i>Company</i>
Load Side Conduit and Conductors	Customer	Customer
Load Side Terminations	<i>Company</i>	<i>Company</i>
Ground Rod(s), Conductor or Grid	<i>Company</i>	<i>Company</i>

Point of Delivery:

Underground Service Commercial – Point where the *Company's* facilities are first connected to the electric facilities of the customer.

DRAWING PM-40

OUTDOOR COMPANY OWNED UNDERGROUND PRIMARY METER INSTALLATION

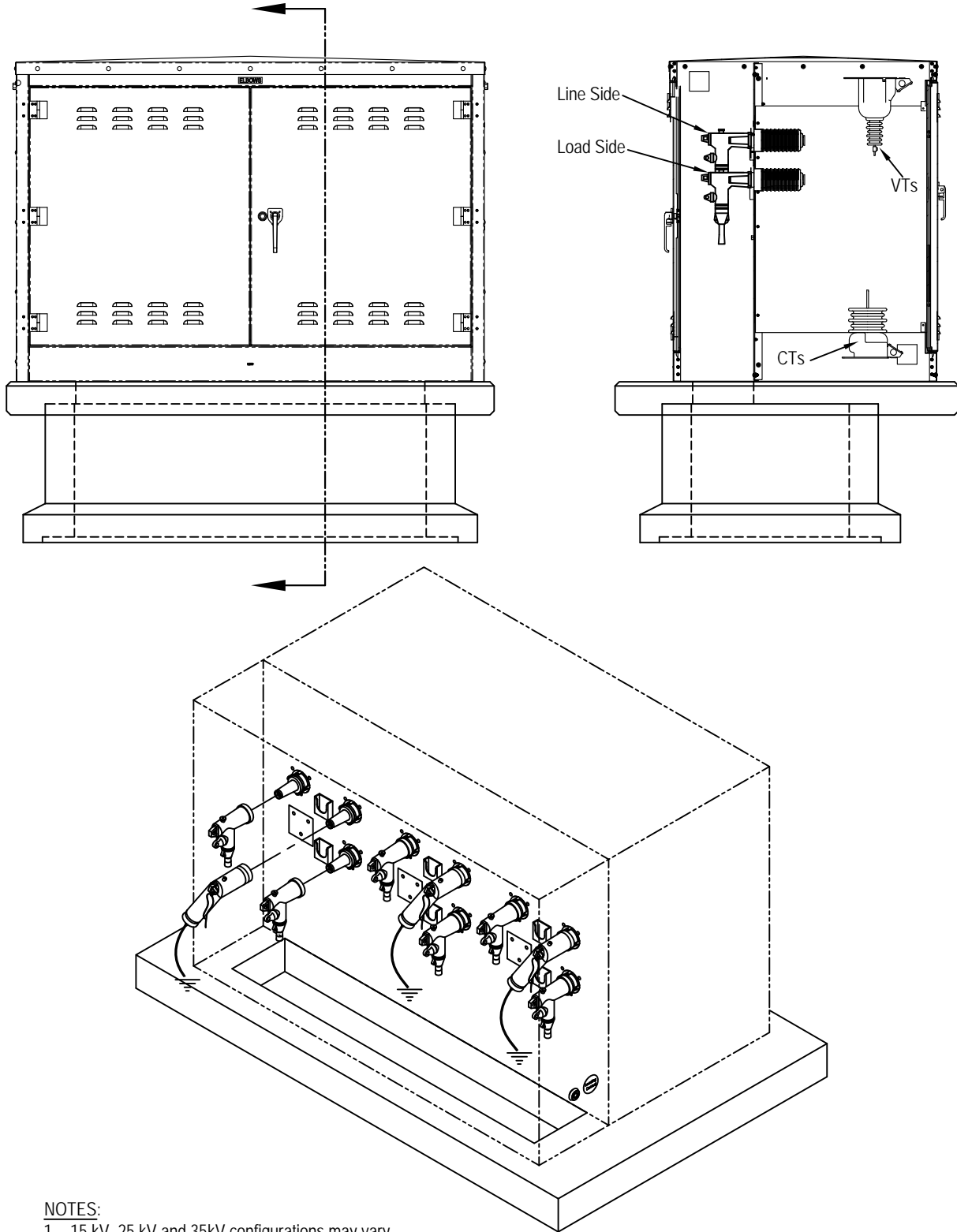

NOTES:

1. 15 kV, 25 kV and 35kV configurations may vary.
2. See [Section 4.13](#), primary voltage (above 480 volts) for installation details and requirements.
3. In TX, NM, and CO only.
4. Customer owned conductors must match company owned conductor sizes.
5. In areas where there will be above ground metal equipment within 6 ft of switchgear, the NESC requires the equipment to be grounded and the grounds bonded. Install 8 ft of #4 Cu bonding wire 3 ft to the side, 6 in back from the front of the pad and buried 12 in deep. Connect the coil to the ground rod lug, not the switchgear.

TABLE OF RESPONSIBILITY

Drawing TM-10		
ITEM, MATERIAL OR WORK DESCRIPTION	PARTY TO FURNISH, OWN AND MAINTAIN	PARTY TO INSTALL
Permits and Inspections	Customer	N/A
Overhead Service Drop	<i>Company</i>	<i>Company</i>
Meter Socket Mounting Structure and OH Point of Attachment	Customer	Customer
Service Entrance Conduit and Conductor	Customer	Customer
Meter Socket	Customer	Customer
Billing Meter	<i>Company</i>	<i>Company</i>
Load Side Conduit and Conductor	Customer	Customer
Ground Rod(s)	Customer	Customer

Point of Delivery:

Overhead Service Commercial – Point where the *Company's* facilities are first connected to the electric facilities of the customer.

DRAWING TM-10

TEMPORARY SERVICE INSTALLATION FROM AN OVERHEAD SECONDARY SUPPLY

Services up to 320 amp 1Ø-3Ø
Commercial Service

Installation shall be outside the utility easement and no closer than 10'
or a maximum of 70' with a conductor no larger than 4/0 from the
Company's secondary supply point.

Temporary service installations subject to cold sequence requirements.

4"x4" post or meter pole furnished, installed and owned by customer
Utility Pole Designation = Class 7 minimum or Class 6
Pole Height = 25' Minimum
Pole Strength = 1200 ft-lb minimum 5'-6" embedded per CR-110
Circumference = at ground line 23.5", at pole top 15"
Pole must be treated to prevent ground line decay.

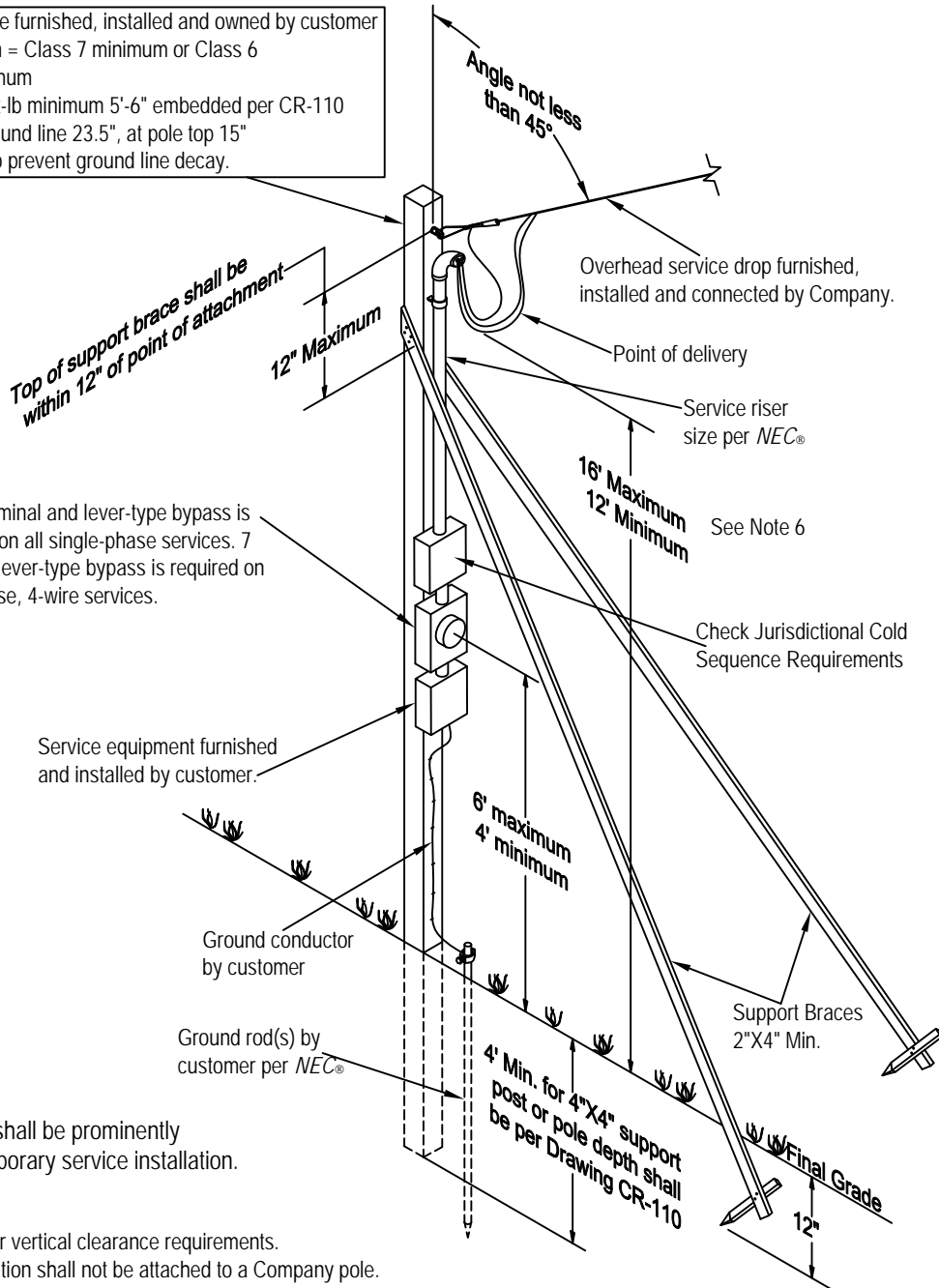

A 5th terminal and lever-type bypass is required on all single-phase services. 7 terminal lever-type bypass is required on all 3-phase, 4-wire services.

Service address shall be prominently displayed on temporary service installation.

NOTES:

1. See [Section 4.2](#) for vertical clearance requirements.
2. Temporary installation shall not be attached to a Company pole.
3. Support may require additional braces to be protected from vehicular and other construction hazards.
4. Make sure area is clear of underground obstructions before installing support or ground rod.
5. Service drop shall not be at an angle of less than 45° from vertical.
6. If utility designated pole is used, the 16' maximum can be increased to 24' maximum.

TABLE OF RESPONSIBILITY

Drawing TM-20		
ITEM, MATERIAL OR WORK DESCRIPTION	PARTY TO FURNISH, OWN AND MAINTAIN	PARTY TO INSTALL
Permits and Inspections	Customer	N/A
Underground Service Lateral	Customer	Customer
Meter Socket Mounting Structure	Customer	Customer
Service Entrance Conduit and Conductor	Customer	Customer
Meter Socket	Customer	Customer
Billing Meter	<i>Company</i>	<i>Company</i>
Load Side Conduit and Conductor	Customer	Customer
Ground Rod(s)	Customer	Customer

Point of Delivery:

Underground Service Commercial – Point where the *Company's* facilities are first connected to the electric facilities of the customer.

DRAWING TM-20

TEMPORARY SERVICE INSTALLATION FROM AN UNDERGROUND SECONDARY SUPPLY PEDESTAL Services up to 320 amp 1Ø Commercial Service

The installation shall be outside utility easement and shall be not less than 6' from the service pedestal.

Temporary service installations subject to cold sequence requirements.

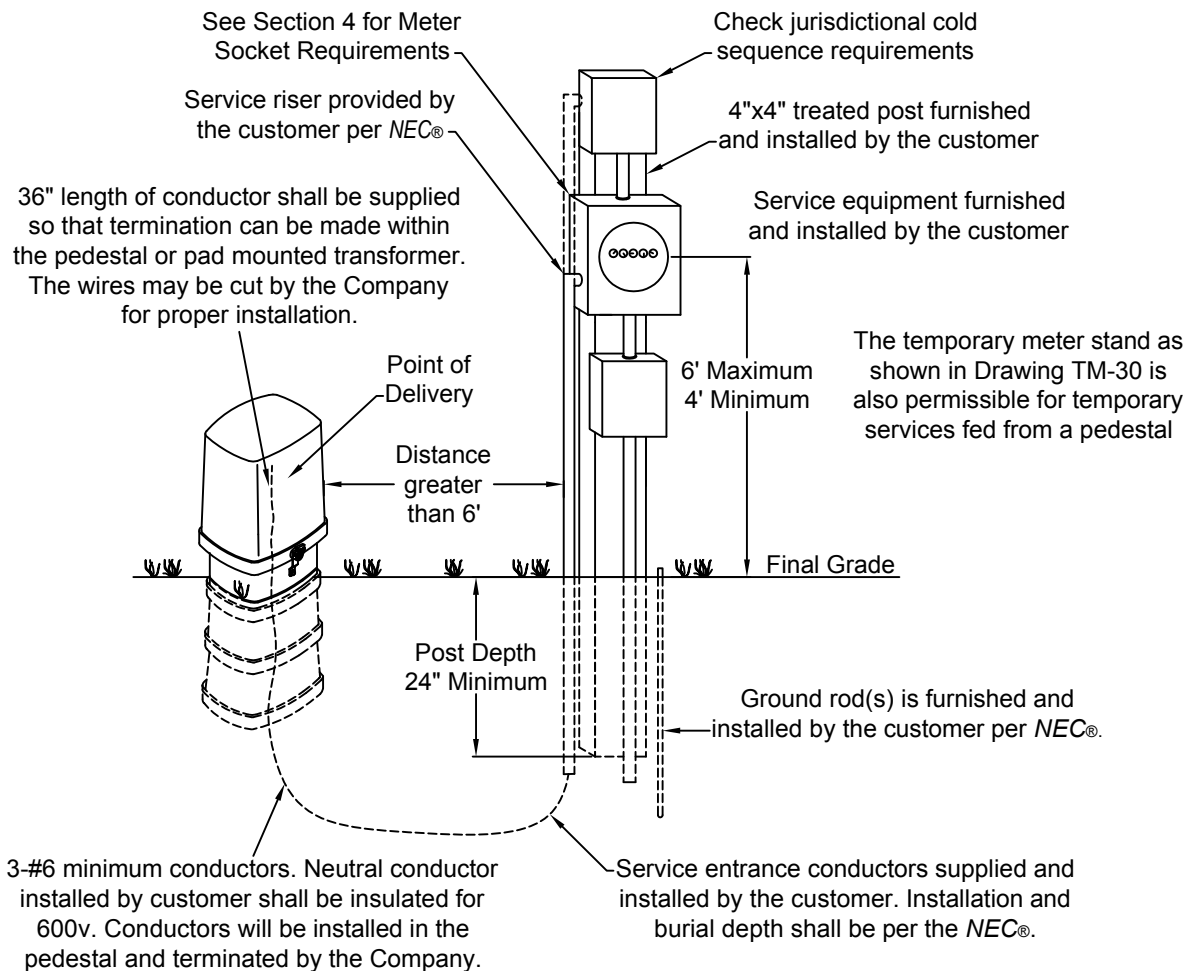

Service address shall be prominently displayed on the temporary service installation.

Notes:

1. Entry into service pedestal shall be made by company.
2. As an alternative between the utility equipment and the meter housing, 3 - #6 minimum insulated conductors can be run in a liquid tight flexible nonmetallic conduit with 1-1/2" liquid tight box connectors. The maximum length of the conduit run should be 12 ft. and placed in an area protected from vehicular traffic and mechanical damage.

TABLE OF RESPONSIBILITY

Drawing TM-30		
ITEM, MATERIAL OR WORK DESCRIPTION	PARTY TO FURNISH, OWN AND MAINTAIN	PARTY TO INSTALL
Permits and Inspections	Customer	N/A
Service Lateral	Customer	Customer
Meter Socket Mounting Structure	Customer	Customer
Service Entrance Conduit and Conductor	Customer	Customer
Meter Socket	Customer	Customer
Billing Meter	<i>Company</i>	<i>Company</i>
Load Side Conduit and Conductor	Customer	Customer
Ground Rod(s)	Customer	Customer

Point of Delivery:

Underground Service Commercial – Point where the *Company's* facilities are first connected to the electric facilities of the customer.

DRAWING TM-30

TEMPORARY SERVICE INSTALLATION FROM AN UNDERGROUND SECONDARY SUPPLY

Services up to 320 amp 1Ø-3Ø
Commercial Service

Temporary service installations subject to cold sequence requirements.

The temporary meter stand as shown in Drawing TM-20 is also permissible for temporary service fed from a transformer

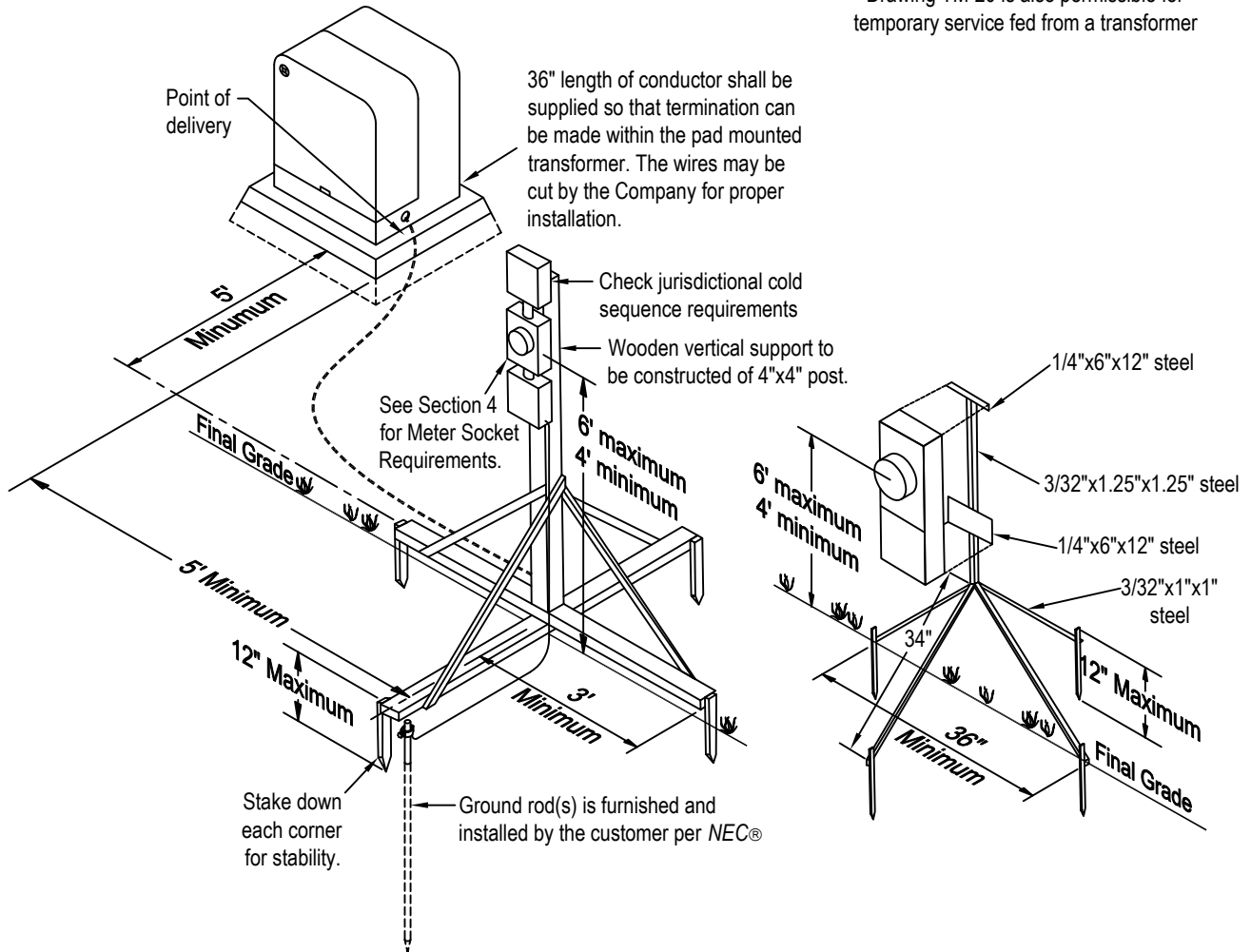

Service address shall be prominently displayed on the temporary service installation.

Notes:

1. Entry into pad mounted transformer shall be made by Company.
2. Installation and burial depth of direct buried service conductors shall be per the NEC.
3. As an alternative between the utility equipment and the meter housing, 3 - #6 minimum insulated conductors can be run in a liquid tight flexible nonmetallic conduit with 1-1/2" liquid tight box connectors. The maximum length of the conduit run should be 12 ft. and placed in an area protected from vehicular traffic and mechanical damage.

TABLE OF RESPONSIBILITY

Drawing IR-20		
ITEM, MATERIAL OR WORK DESCRIPTION	PARTY TO FURNISH, OWN AND MAINTAIN	PARTY TO INSTALL
Permits and Inspections	Customer	N/A
Overhead Service Drop	Company	Company
Underground Service Lateral (Residential)	Company	Company
Underground Service Lateral (Commercial) (except WI and MI)	Customer	Customer
Normally Closed Relay Within Meter	Company	Company
Service Entrance Conduit	Customer	Customer
Meter Socket(s)	Customer	Customer
Control Wire from Meter to Junction Box	Company	Company
NEMA 3R Junction Box	Customer	Customer
Contactor or Relay	Customer	Customer
Conduit and Conductor for Load Control Device	Customer	Customer
Supply Voltage for Load Control Device	Customer	Customer
Billing Meter	Company	Company
Load Side Conduit and Conductor	Customer	Customer

DRAWING IR-20

TIME OF DAY, LIMITED OR OPTIONAL OFF PEAK METERING MI, MN, ND, SD, WI, ONLY

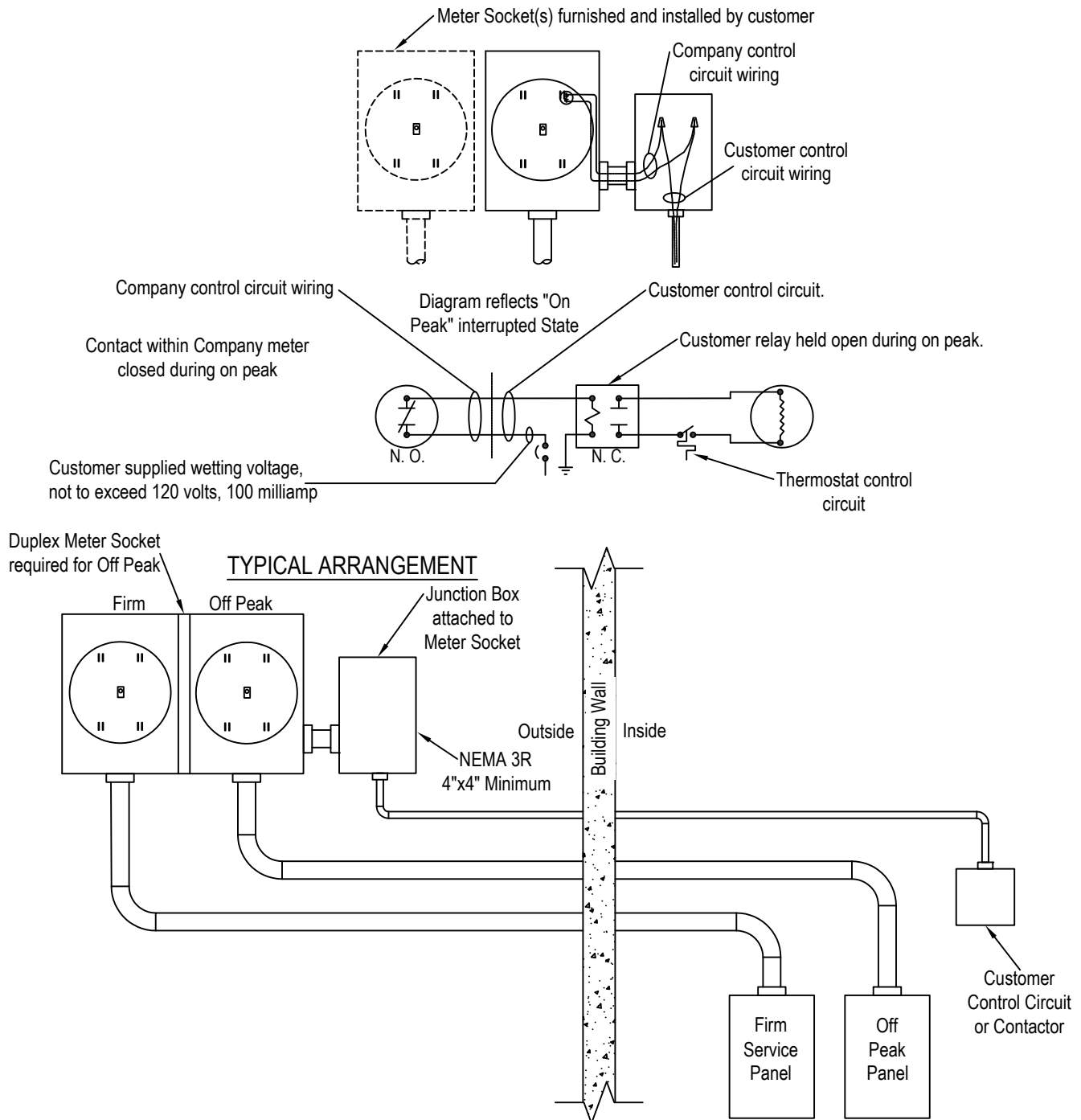

Control circuit is designed to allow customer to override automatic control of load. In the event the customer wants to operate their equipment during "on peak" it can be accomplished by simply de-energizing the control circuit.

NOTES:

1. Company will provide normally closed relay within meter.
2. Company will provide control wire from meter to junction box.
3. Customer will provide and install meter socket(s).
4. Customer will provide and install NEMA 3R Junction Box within 24" of meter socket
5. Customer will provide and install conduit and wiring for load control circuit.
6. Customer will provide and install normally closed relay or contactor.

TABLE OF RESPONSIBILITY

Drawing IR-30		
ITEM, MATERIAL OR WORK DESCRIPTION	PARTY TO FURNISH, OWN AND MAINTAIN	PARTY TO INSTALL
Permits and Inspections	Customer	N/A
Overhead Service Drop	Company	Company
Underground Service Lateral (Residential)	Company	Company
Underground Service Lateral (Commercial) (except WI and MI)	Customer	Customer
Service Entrance Conduit	Customer	Customer
Meter Socket(s)	Customer	Customer
NEMA 3R Junction Box	Customer	Customer
Radio-controlled Switch with Normally Closed Relay	Company	Company
Conduit and Conductor for Load Control Device	Customer	Customer
Supply Voltage for Load Control Device	Customer	Customer
Billing Meter	Company	Company
Load Side Conduit and Conductor	Customer	Customer

DRAWING IR-30

DUAL FUEL SERVICE METERING MN, ND, SD, ONLY

Contact Company's local Electric Meter Department for additional information.

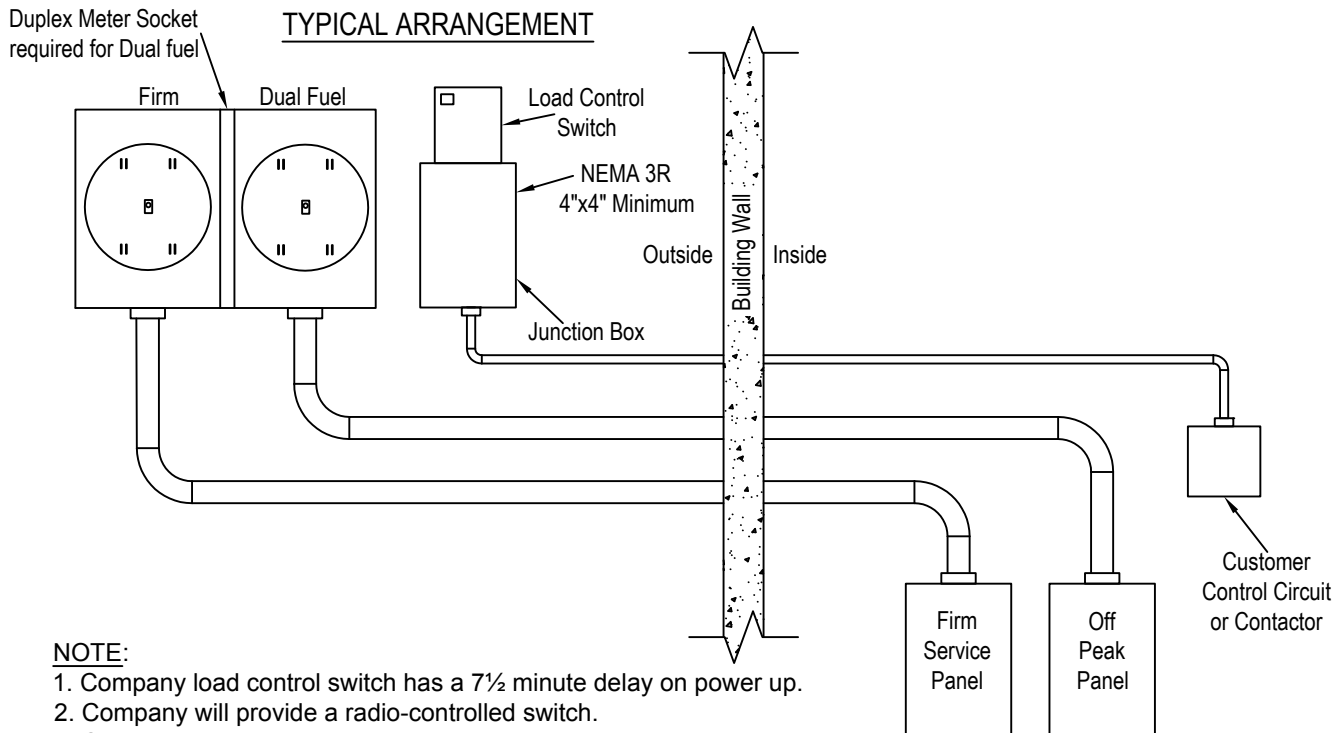
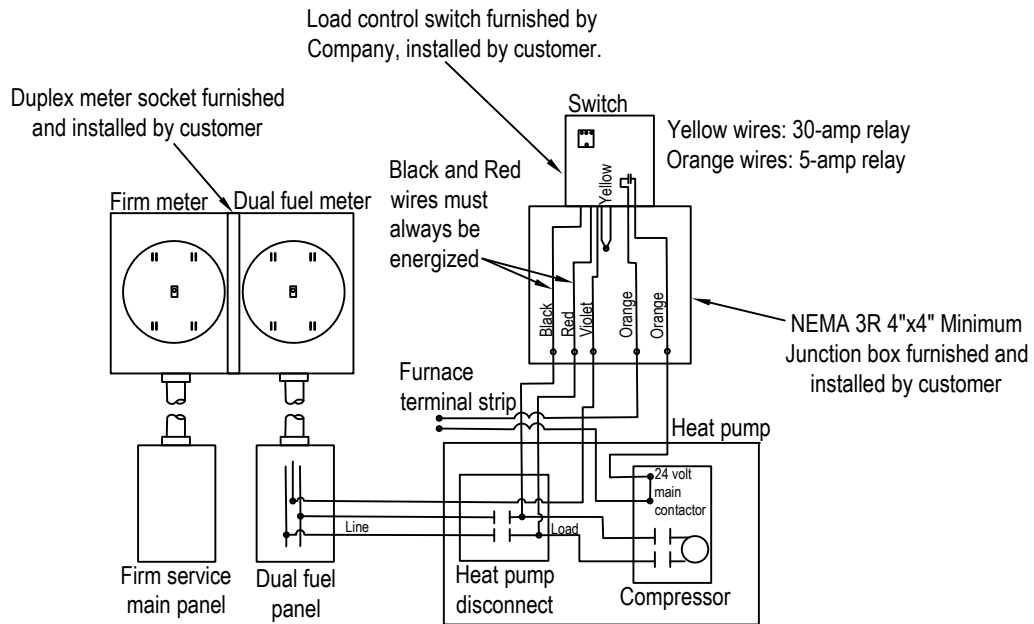

NOTE:

1. Company load control switch has a 7½ minute delay on power up.
2. Company will provide a radio-controlled switch.
3. Company will provide a normally closed relay within switch.
4. Customer will provide and install meter socket(s).
5. Customer will provide and install NEMA 3R Junction Box within 24" meter socket.
6. Customer will provide and install a radio-controlled switch.
7. Customer will provide and install conduit and wiring for load control circuit.
9. Customer will provide and install a normally closed relay or contactor.

TABLE OF RESPONSIBILITY

Drawing IR-40		
ITEM, MATERIAL OR WORK DESCRIPTION	PARTY TO FURNISH, OWN AND MAINTAIN	PARTY TO INSTALL
Self-Contained Meter Socket	Customer	Customer
Transformer-Rated Meter Socket	<i>Company</i>	Customer
Billing Meter	<i>Company</i>	<i>Company</i>
Conduit from Meter Socket to Pulse Device	<i>Company</i>	<i>Company</i>
Data Pulse Device	<i>Company</i>	<i>Company</i>
Junction Box	<i>Company</i>	<i>Company</i>
Data Recorder, if Required	<i>Company</i>	<i>Company</i>
Wires from Pulse Device to Customer's Equipment	Customer	Customer
Conduit from Pulse Device to Customer's Equipment	Customer	Customer

DRAWING IR-40

DATA PULSE DEVICE FOR CUSTOMER LOAD MANAGEMENT SYSTEM

Customer contacts are fused at 1/2 amp, and not more than 120 volts AC or DC shall be applied to any set of contacts.

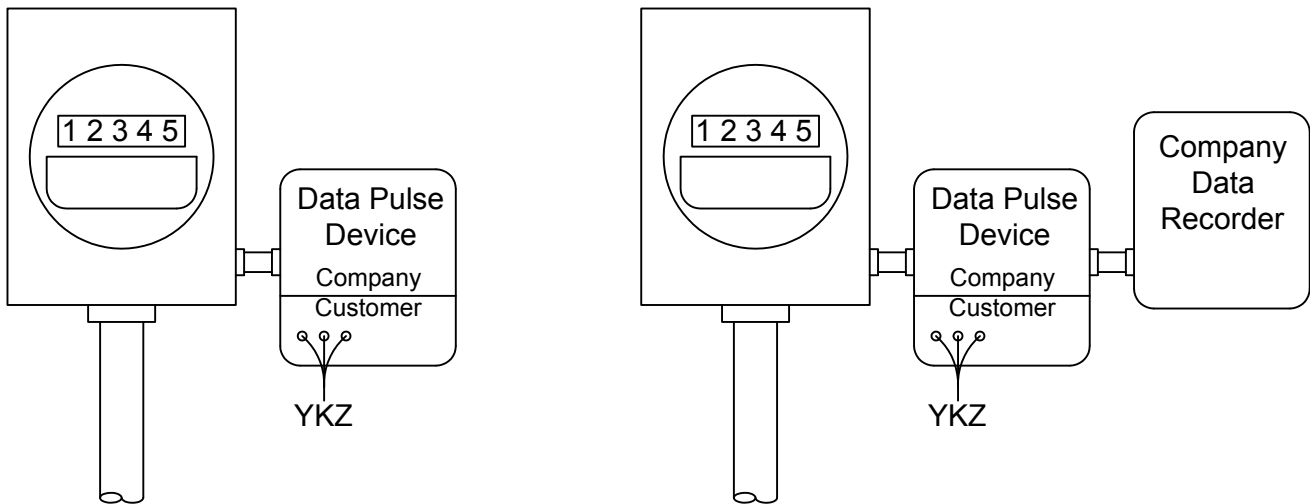

NOTES:

1. The customer accessible terminal strip may be contained in the device box with Y, K, Z channel indication lights.
2. The customer accessible data pulse may be installed in an external box without terminal strip and indication lights.
3. The type of device and box to be supplied to the customer shall be decided solely by the Company.
4. One data pulse box device is required for each set of customer pulses.

TABLE OF RESPONSIBILITY

Drawing EV-10		
ITEM, MATERIAL OR WORK DESCRIPTION	PARTY TO FURNISH, OWN AND MAINTAIN	PARTY TO INSTALL
Permits and Inspections	Customer	N/A
Service Entrance Conductor*	Customer	Customer
Underground Service Lateral	<i>Company</i>	<i>Company</i>
Service Entrance Conduit	Customer	Customer
Duplex Meter Socket	Customer	Customer
Billing Meter	<i>Company</i>	<i>Company</i>
Load Side Conduit, Conductor, Panels	Customer	Customer

Point of Delivery

Point where the *Company's* facilities are first connected to the electric facilities of the customer.

*The service entrance conductor refers to the conductor going through the mast between the line side of the meter socket, through the weather head, and to the point of delivery

DRAWING EV-10

Duplex Underground/Overhead

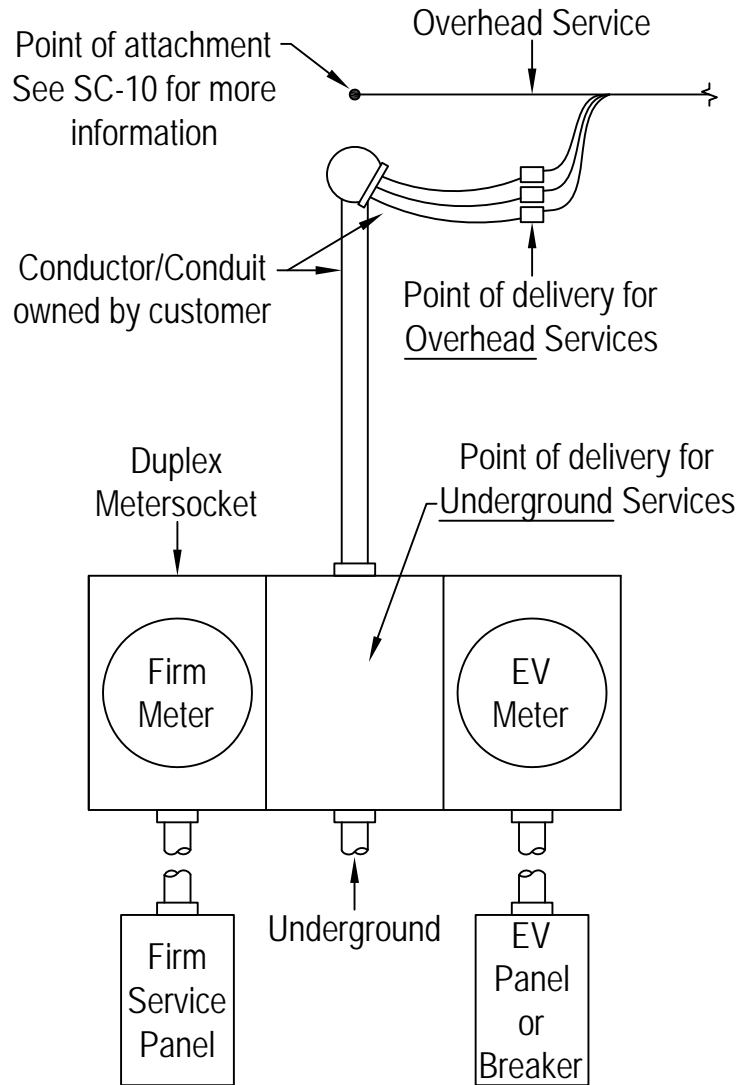

Notes:

1. EV SERVICE METERING MN ONLY

TABLE OF RESPONSIBILITY

Drawing EV-20		
ITEM, MATERIAL OR WORK DESCRIPTION	PARTY TO FURNISH, OWN AND MAINTAIN	PARTY TO INSTALL
Permits and Inspections	Customer	N/A
Overhead Service Conduit	Customer	Customer
Service Entrance Conductor*	Customer	Customer
Junction in Drip Loop	<i>Company</i>	<i>Company</i>
Self-Contained Meter Socket	Customer	Customer
Billing Meter	<i>Company</i>	<i>Company</i>
Load Side Conduit, Conductor, Panels	Customer	Customer

Point of Delivery:

Overhead Service Residential – Point where the *Company's* facilities are first connected to the electric facilities of the customer.

The junction is made in the drip loop between the conductor exiting the weather head and the overhead service drop. The connection will be made by the *Company*.

*The service entrance conductor refers to the conductor going through the mast between the line side of the meter socket, through the weather head, and to the point of delivery.

DRAWING EV-20

OVERHEAD SERVICE

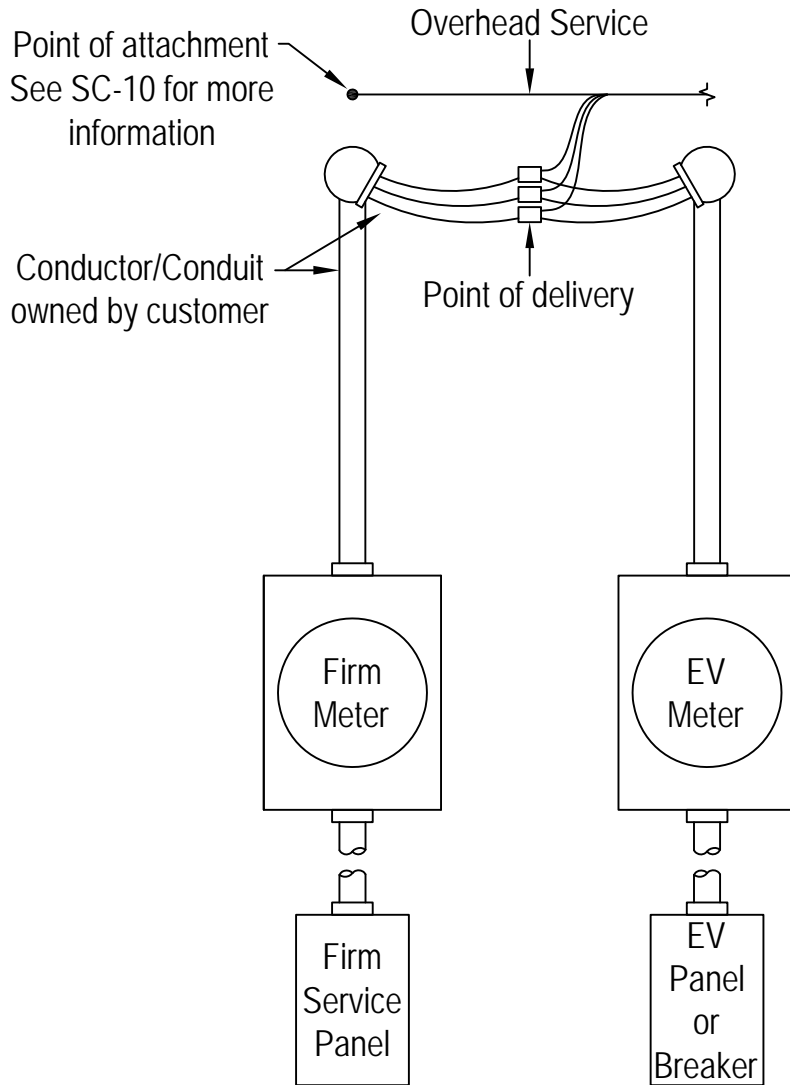

SEPARATE SOCKET OPTION

NOTES:

1. EV SERVICE METERING MN ONLY.
2. Riser conduit and conductor supplied and installed by customer/electrician.
3. Point of delivery in service loop.

TABLE OF RESPONSIBILITY

Drawing EV-30		
ITEM, MATERIAL OR WORK DESCRIPTION	PARTY TO FURNISH, OWN AND MAINTAIN	PARTY TO INSTALL
Permits and Inspections	Customer	N/A
Underground Service Lateral	<i>Company</i>	<i>Company</i>
Junction Box/Wire way (Lockable)	Customer	Customer
Point of Connection	Customer	Customer
Self-Contained Meter Socket	Customer	Customer
Billing Meter	<i>Company</i>	<i>Company</i>
Load Side Conduit, Conductor, Panels	Customer	Customer

Point of Delivery:

Underground Service Residential – Point where the *Company's* facilities are first connected to the electric facilities of the customer.

DRAWING EV-30

UNDERGROUND SERVICE

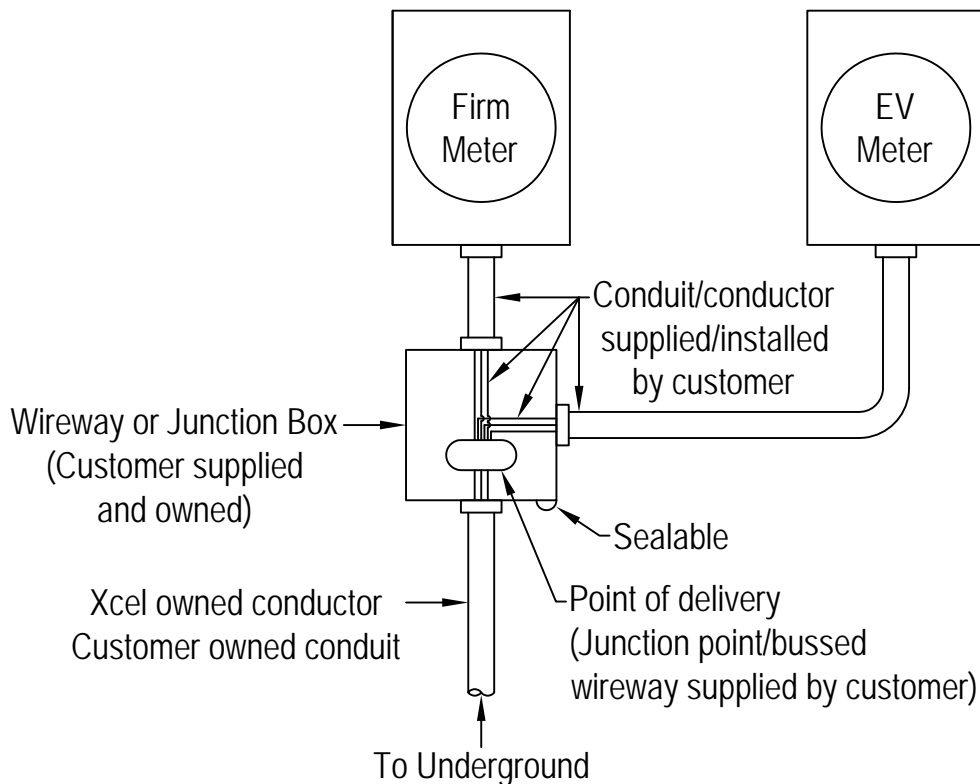

NOTES:

1. EV SERVICE METERING MN ONLY.
2. Need to coordinate disconnect/reconnect with Xcel builders line.
3. Point of delivery in wireway, conductors after that point supplied by customer.
4. Junction point or bussed wireway supplied by customer.

TABLE OF RESPONSIBILITY

Drawing CC-10 & 10A		
ITEM, MATERIAL OR WORK DESCRIPTION	PARTY TO FURNISH, OWN AND MAINTAIN	PARTY TO INSTALL
Permits and Inspections	Customer	N/A
Conductors from Transformer to Secondary Connection Cabinet (SCC)	Company	Company
SCC Line Side Termination Lugs	Company	Company
Cable Tray	Customer	Customer
SCC Concrete Pad	Customer	Customer
Precast Transformer Pad	Company	Company
Secondary Connection Cabinet (SCC)	Customer	Customer
SCC Load Side Conduit, Sweeps and Conductor	Customer	Customer
SCC Ground Rod, Conductor to neutral bus and Case Ground	Customer	Customer

Point of Delivery:

Underground Service Commercial – Point where the *Company's* facilities are first connected to the electric facilities of the customer.

DRAWING CC-10

CUSTOMER OWNED SECONDARY CONNECTION CABINET (SCC)

CUSTOMER OWNED SECONDARY CONNECTION CABINET FRONT VIEW

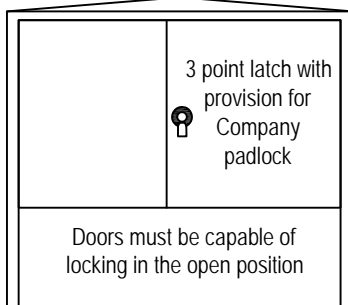

Customer Owned Secondary Connection Cabinet

Company will terminate all conductors in Company-owned pad-mounted transformer (one run per phase showing)

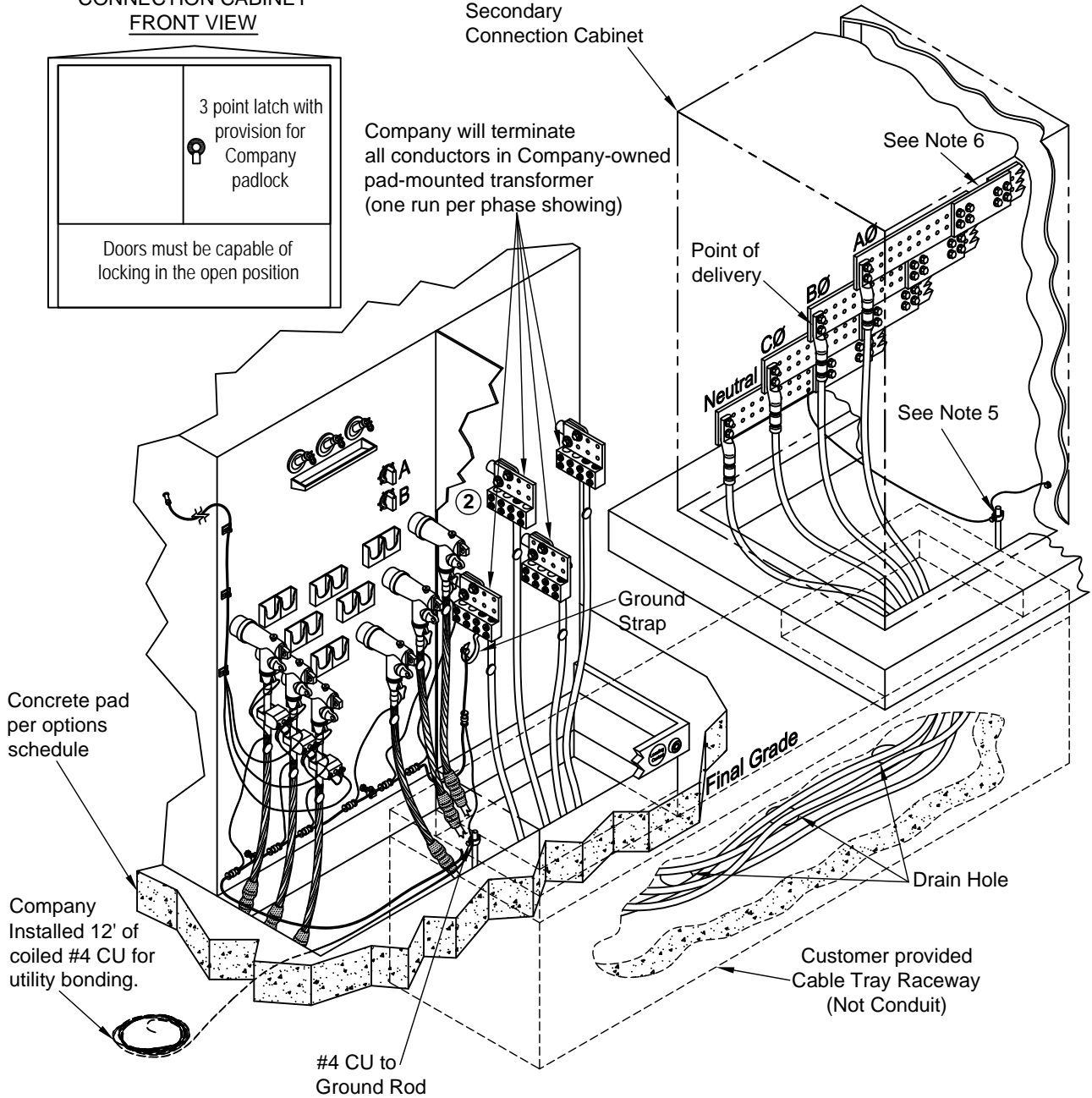

NOTES:

1. Company will furnish and install precast transformer pad and pad-mounted transformer.
2. Company will furnish and install conductors from transformer to secondary connection cabinet including termination lugs at secondary connection cabinet.
3. Customer shall furnish, install and maintain continuous and/or separate pad for secondary connection cabinet per drawing pages [CC-40](#) through [CC-60E](#).
4. Customer shall furnish, install and maintain secondary connection cabinet and bus bar hole pattern shall have NEMA spacing (1-3/4" on center) and be centered on bar. SCC bus bar holes to accommodate 1/2" bolts
5. Customer to furnish ground rod for bonding to enclosure and at right side of neutral bus bar installed per NEC®.
6. All secondary connection cabinets shall have a removable bus link section for each phase and the neutral bus (See Section 4.12.2).

DRAWING CC-10A

SECONDARY CONNECTION CABINET (SCC) PRE-CAST CABLE TRAY SPECIFICATION

A service connection cabinet is required when there are more than (8) runs per phase, or when the service lateral size exceeds 500 kcmil Cu or 750 kcmil Al. If a service connection cabinet is required, it shall be purchased, installed and maintained at the expense of the customer. The customer will provide a precast SCC pad and the Company will provide a precast transformer pad or, in areas where frost heaving may be a concern, the customer will provide a single poured-in-place concrete pad to support both the transformer and the SCC.

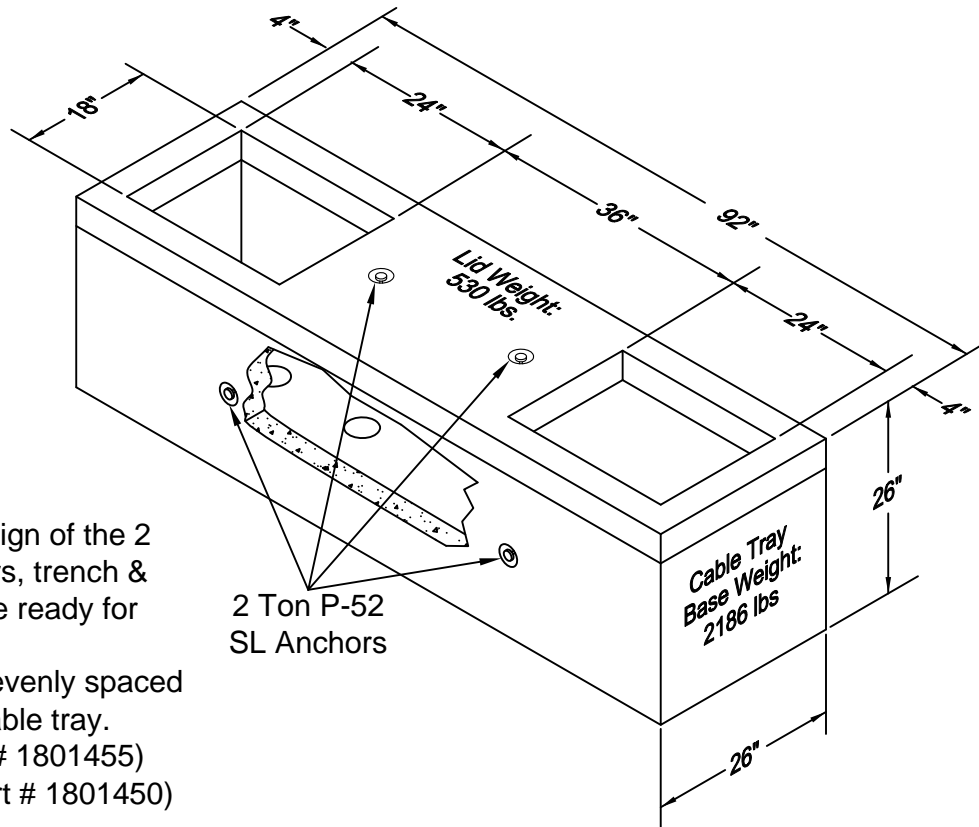

Pad Notes:

1. Based on lifting design of the 2 ton P-52 SL Anchors, trench & prep work should be ready for supplier installation.
2. 4" Drain holes are evenly spaced in the floor of the cable tray.
3. Lid (Oldcastle part # 1801455)
4. Base (Oldcastle part # 1801450)

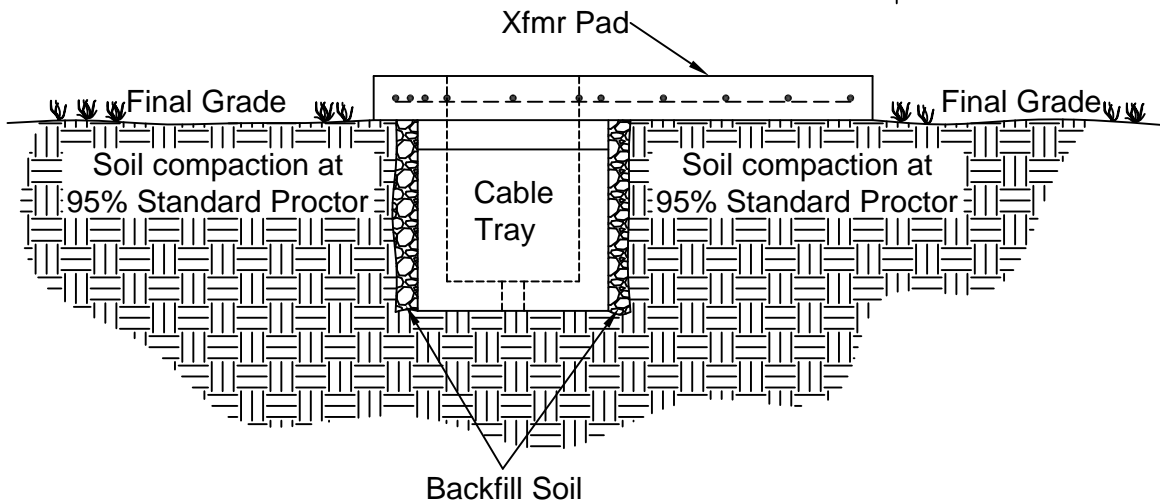

This Page Intentionally Left Blank

TABLE OF RESPONSIBILITY

Drawing CC-20		
ITEM, MATERIAL OR WORK DESCRIPTION	PARTY TO FURNISH, OWN AND MAINTAIN	PARTY TO INSTALL
Permits and Inspections	Customer	N/A
Conductors from Transformer to Secondary Connection Cabinet (SCC)	<i>Company</i>	<i>Company</i>
SCC Line Side Termination Lugs	<i>Company</i>	<i>Company</i>
Cable Tray	Customer	Customer
SCC Concrete Pad	Customer	Customer
Precast Transformer Pad	<i>Company</i>	<i>Company</i>
SCC with Metering Provisions	Customer	Customer
Metering Circuit Conduit	Customer	Customer
Metering Circuit Conductors	<i>Company</i>	<i>Company</i>
Current Transformers	<i>Company</i>	Customer
Meter Socket	<i>Company</i>	Customer
Billing Meter	<i>Company</i>	<i>Company</i>
SCC Load Side Conduit, Sweeps and Conductor	Customer	Customer
SCC Ground Rod, Conductor to neutral bus and Case Ground	Customer	Customer

Point of Delivery:

Underground Service Commercial – Point where the *Company's* facilities are first connected to the electric facilities of the customer.

DRAWING CC-20

CUSTOMER OWNED PAD-MOUNTED METERING SECONDARY CONNECTION CABINET

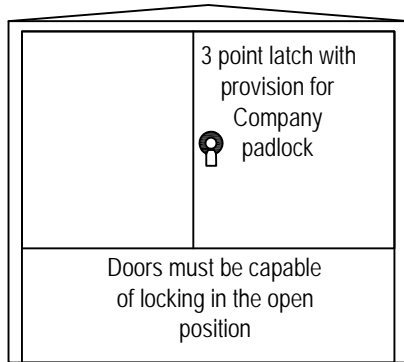

FRONT VIEW

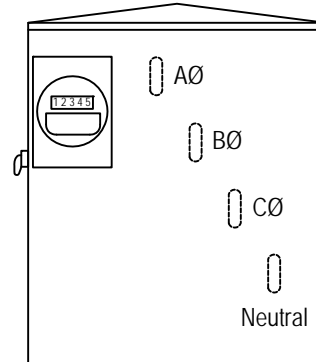

SIDE VIEW

INSTALLED NEXT TO
TRANSFORMER

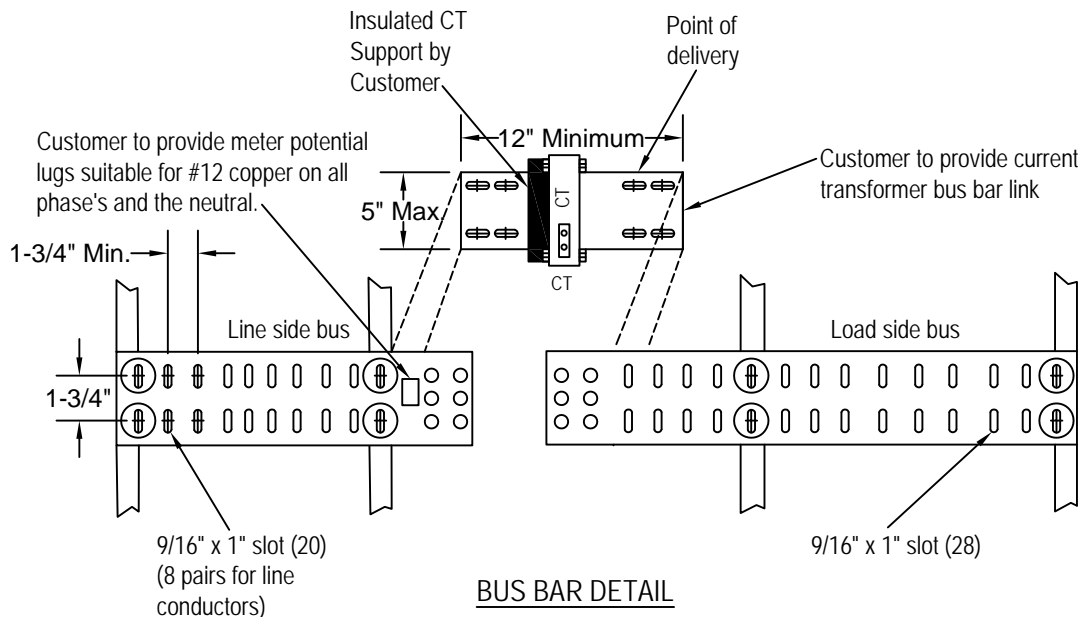

NOTES:

1. Bus bar phase arrangement shall be A, B, C from front to back, Top to Bottom, Left to Right, NEC® 408.3 (e).
2. "B" phase shall be that phase having the higher voltage to ground on 3-phase, 4-wire, delta-connected systems.
3. The high-leg shall be marked with an outer finish that is orange in color. NEC® 110.15
4. Company will furnish and install precast transformer pad and pad-mounted transformer.
5. Company will furnish and install conductors from transformer to secondary connection cabinet including termination lugs at secondary connection cabinet.
6. Customer shall furnish, install and maintain continuous and/or separate pad for secondary connection cabinet.
7. Customer shall furnish, install and maintain secondary connection cabinet and bus bar hole pattern shall have NEMA spacing (1-3/4" on center) and be centered on bar. SCC bus bar holes to accommodate 1/2" bolts.

TABLE OF RESPONSIBILITY

Drawing CC-30		
ITEM, MATERIAL OR WORK DESCRIPTION	PARTY TO FURNISH, OWN AND MAINTAIN	PARTY TO INSTALL
Permits and Inspections	Customer	N/A
Conductors from Transformer to Secondary Connection Cabinet (SCC)	<i>Company</i>	<i>Company</i>
SCC Line Side Termination Lugs	<i>Company</i>	<i>Company</i>
Cable Tray	Customer	Customer
SCC Concrete Pad	Customer	Customer
Precast Transformer Pad	<i>Company</i>	<i>Company</i>
SCC with Metering Provisions	Customer	Customer
Metering Circuit Conduit	Customer	Customer
Metering Circuit Conductors	<i>Company</i>	<i>Company</i>
Current Transformers	<i>Company</i>	Customer
Meter Socket	<i>Company</i>	Customer
Billing Meter	<i>Company</i>	<i>Company</i>
SCC Load Side Conduit, Sweeps and Conductor	Customer	Customer
SCC Ground Rod, Conductor to neutral bus and Case Ground	Customer	Customer

Point of Delivery:

Underground Service Commercial – Point where the *Company's* facilities are first connected to the electric facilities of the customer.

DRAWING CC-30

CUSTOMER OWNED PAD-MOUNTED METERING SECONDARY CONNECTION CABINET (SCC) WITH CUSTOMER DISCONNECT SWITCH

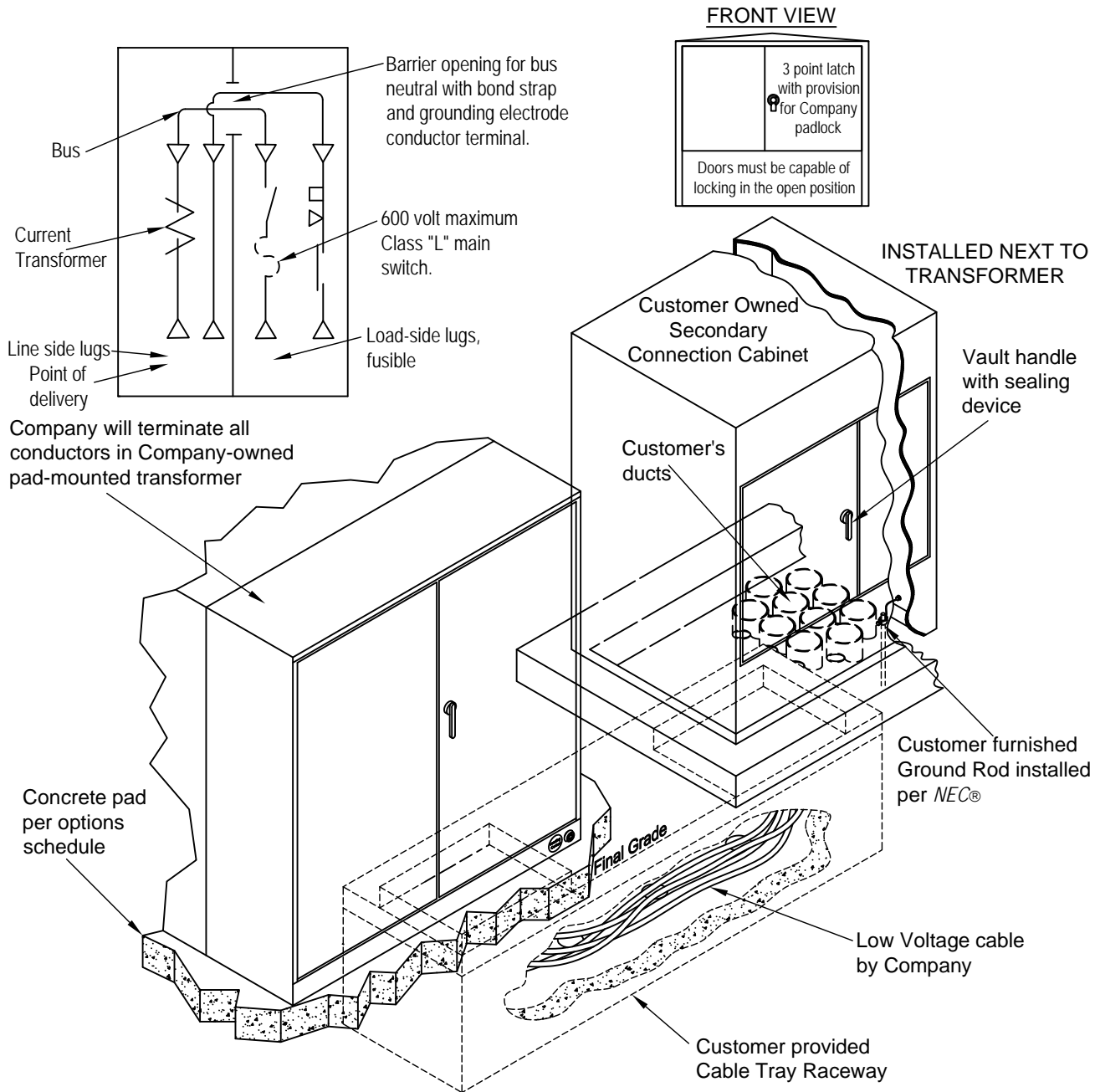

NOTES:

1. Four foot clearance shall be maintained on door sides and three foot clearance on non-door sides of SCC.
2. Customer shall furnish and install ground rod(s) for SCC.
3. Company will furnish and install precast transformer pad and pad-mounted transformer.
4. Company will furnish and install conductors from transformer to secondary connection cabinet including termination lugs at secondary connection cabinet.
5. Customer shall furnish, install and maintain continuous and/or separate pad for secondary connection cabinet per drawing pages [CC-40](#) through [CC-60E](#).
6. Customer shall furnish, install and maintain secondary connection cabinet and bus bar hole pattern shall have NEMA spacing (1-3/4" on center) and be centered on bar. SCC bus bar holes to accommodate 1/2" bolts.

TABLE OF RESPONSIBILITY

Drawing CC-40 & 40A		
ITEM, MATERIAL OR WORK DESCRIPTION	PARTY TO FURNISH, OWN AND MAINTAIN	PARTY TO INSTALL
Permits and Inspections	Customer	N/A
Conductors from Transformer to Secondary Connection Cabinet (SCC)	<i>Company</i>	<i>Company</i>
SCC Line Side Termination Lugs	<i>Company</i>	<i>Company</i>
Cable Tray	Customer	Customer
SCC Concrete Pad	Customer	Customer
Precast Transformer Pad	<i>Company</i>	<i>Company</i>
Secondary Connection Cabinet (SCC)	Customer	Customer
SCC Load Side Conduit, Sweeps and Conductor	Customer	Customer
SCC Ground Rod, Conductor to neutral bus and Case Ground	Customer	Customer

DRAWING CC-40

SECONDARY CONNECTION CABINET-TRANSFORMER PRE-CAST PAD

15/25 kV for 75-500 kVA & 15/25 kV for 750-2500 kVA

In-Line Orientation-Preferred

Pad Notes:

- 1) Location of pad placement shall be prepared in advance to ensure proper compaction of soil and leveling to cable tray
- 2) Top surface of cable tray will be installed at a depth consistent with the Standard Pre-cast transformer pad final grade including soil compaction requirement at 95% Standard Proctor.
- 3) All dimension X's for SCC pad shall be based on customer chosen SCC footprint width ($X1+18"+X1$) and depth ($X2+18"+X2$).
- 4) Quantity (X3) of customer required ducts per SCC width.
- 5) Match Points for cable tray in transformer window aligns with the 4" wall into the Primary cavity & flush with Secondary cavity at the transformer barrier wall.

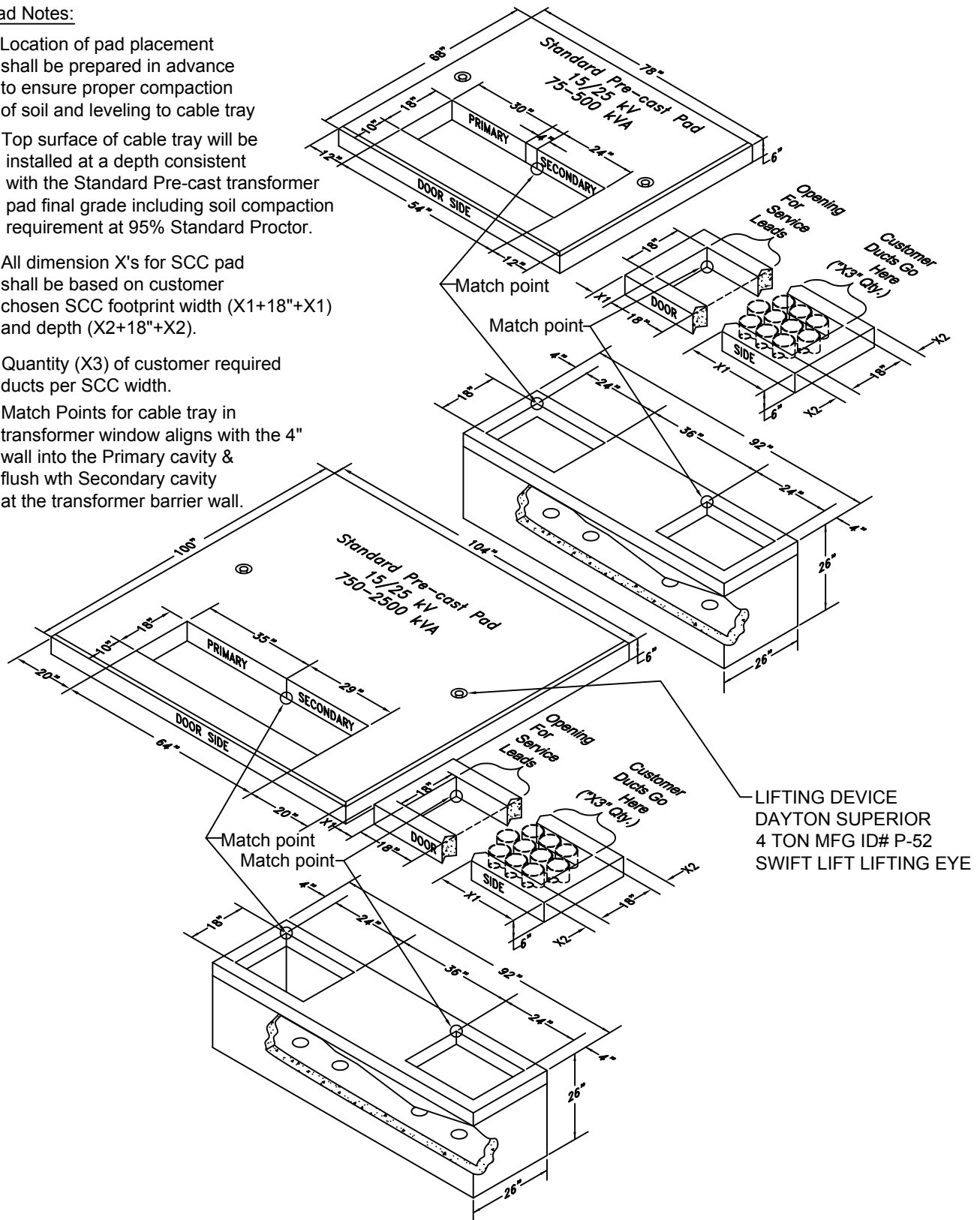

LIFTING DEVICE
 DAYTON SUPERIOR
 4 TON MFG ID# P-52
 SWIFT LIFT LIFTING EYE

DRAWING CC-40A

SECONDARY CONNECTION CABINET-TRANSFORMER PRE-CAST PAD 15/25 kV for 75-500 kVA & 15/25 kV for 750-2500 kVA 90° Orientation

- 1) Location of pad placement shall be prepared in advance to ensure proper compaction of soil and leveling to cable tray
- 2) Top surface of cable tray will be installed at a depth consistent with the Standard Pre-cast transformer pad final grade including soil compaction requirement at 95% Standard Proctor.
- 3) All dimension X's for SCC pad shall be based on customer chosen SCC footprint width ($X1+18"+X1$), depth (X2), and quantity (X3) of customer required ducts.
- 4) Match Points for cable tray in transformer window aligns with the 4" wall into the Primary cavity & flush with Secondary cavity at the transformer barrier wall.

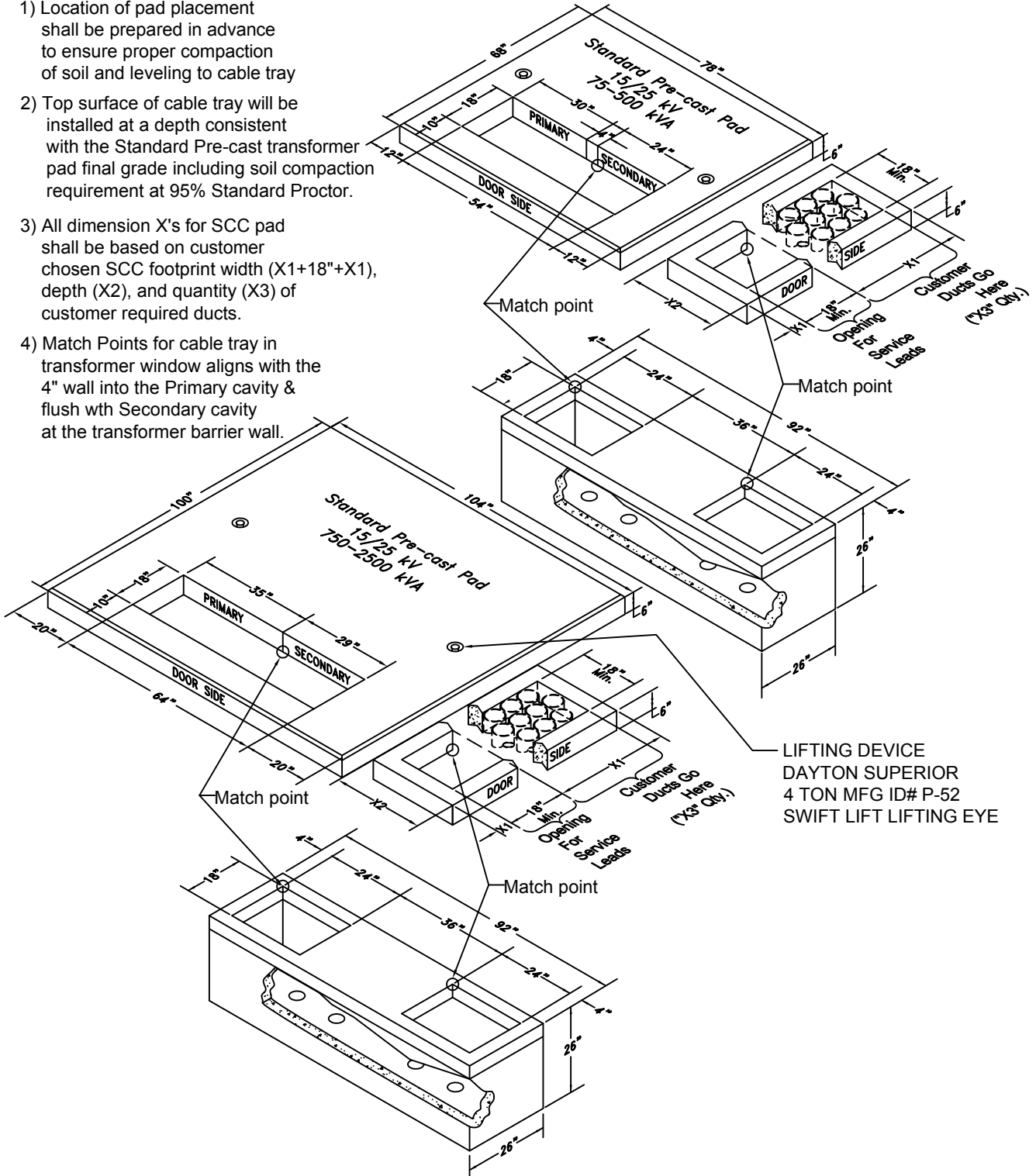

LIFTING DEVICE
DAYTON SUPERIOR
4 TON MFG ID# P-52
SWIFT LIFT LIFTING EYE

This Page Intentionally Left Blank

TABLE OF RESPONSIBILITY

Drawing CC-50, 50A, B, C, D & E

ITEM, MATERIAL OR WORK DESCRIPTION	PARTY TO FURNISH, OWN AND MAINTAIN	PARTY TO INSTALL
Permits and Inspections	Customer	N/A
Conductors from Transformer to Secondary Connection Cabinet (SCC)	Company	Company
SCC Line Side Termination Lugs	Company	Company
Cable Tray	Customer	Customer
SCC Concrete Pad	Customer	Customer
Transformer Pour-In-Place Concrete Pad	Customer	Customer
Secondary Connection Cabinet (SCC)	Customer	Customer
SCC Load Side Conduit, Sweeps and Conductor	Customer	Customer
SCC Ground Rod, Conductor to neutral bus and Case Ground	Customer	Customer
2 - 6", 36" Radius Conduit Elbows for Primary Cable	Customer	Customer

DRAWING CC-50

SECONDARY CONNECTION CABINET AND TRANSFORMER POURED-IN-PLACE PAD 15 & 25 kV for 75-500 kVA In-Line Orientation-Preferred

15 & 25 kV 75-500 kVA	PAD DIMENSIONS (DIM)							REINFORCED STEEL SCHEDULE									
	A	B	C	D	E	F	T	X1	①	②	③	④	⑤	⑥	⑦	⑧	⑨
78" See note 1	68"	54"	12"	18" Min	36"	6"	Bal of SCC width		5-#4	3-#4	3-#4	7-#4	3-#4	2-#4 x 3'0"	14-#4	4-#4	#4

Rebar Notes:

- 1) Rebar schedule #8 is per customer chosen SCC footprint width
- 2) Rebar schedules #1, 2, & 9 (SCC side) is per customer chosen SCC footprint width.

Pad Notes:

- 1) DIM A is maximum transformer width placed on 54" window per transformer barrier wall.
- 2) DIM E is SCC window at 18" minimum for secondary cable leads. DIM X1 is for the balance of the customer chosen SCC footprint width. X3 is customer required quantity of ducts.
- 3) Match Points for cable tray in transformer window aligns with the 4" wall into the Primary cavity & flush with Secondary cavity at the transformer barrier wall.
- 4) Top surface of cable tray will be installed at a depth consistent with the Pour-In-Place transformer pad final grade including soil compaction requirement at 95% Standard Proctor.
- 5) Two 6" - 36" radius conduit elbows for primary cable to extend 3' beyond the front edge of transformer pad.

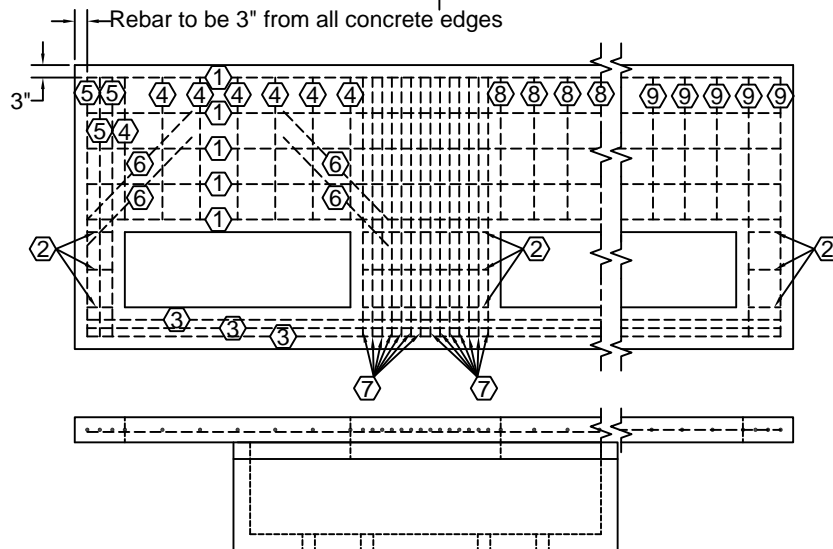
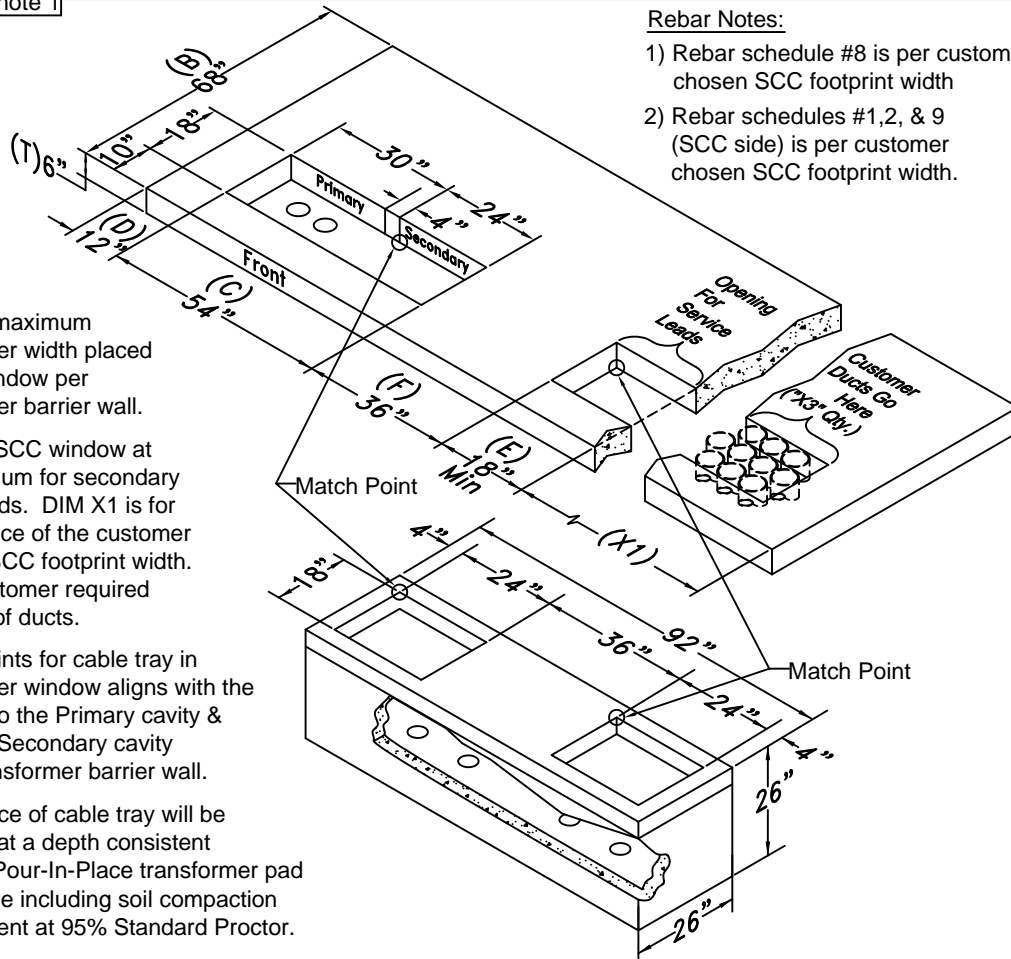

DRAWING CC-50A

SECONDARY CONNECTION CABINET AND TRANSFORMER POURED-IN-PLACE PAD 15 & 25 kV for 75-500 kVA 90° Orientation

15 & 25 kV 75-500 kVA	PAD DIMENSIONS (DIM)								REINFORCED STEEL SCHEDULE									
	A	B	C	D	E	F	T	X1	X2	①	②	③	④	⑤	⑥	⑦	⑧	⑨
	78" See note 1	68"	54"	12"	18" Min	36"	6"	Bal of SCC depth	Bal of SCC width	5-#4	3-#4	3-#4	7-#4	3-#4	2-#4 x 3'0"	14-#4	4-#4	#4

Pad Notes:

- DIM A is maximum transformer width placed on 54" window per transformer barrier wall.
- DIM E is SCC window at 18" minimum for secondary cable leads. Dim X1 is for the balance of the customer chosen SCC footprint depth.
- DIM X2 is overall SCC footprint window width including minimum 18" wide for secondary cable leads. X3 is customer required quantity of ducts.
- Match Points for cable tray in transformer window aligns with the 4" wall into the Primary cavity & flush with Secondary cavity at the transformer barrier wall.
- Top surface of cable tray will be installed at a depth consistent with the Pour-In-Place transformer pad final grade including soil compaction requirement at 95% Standard Proctor.
- Two 6" - 36" radius conduit elbows for primary cable to extend 3' beyond the front edge of transformer pad.

Rebar Notes:

- Rebar schedule #8 is per customer chosen SCC footprint width
- Rebar schedule #'s 1,2 & 9 (SCC side) is per customer chosen SCC footprint depth.

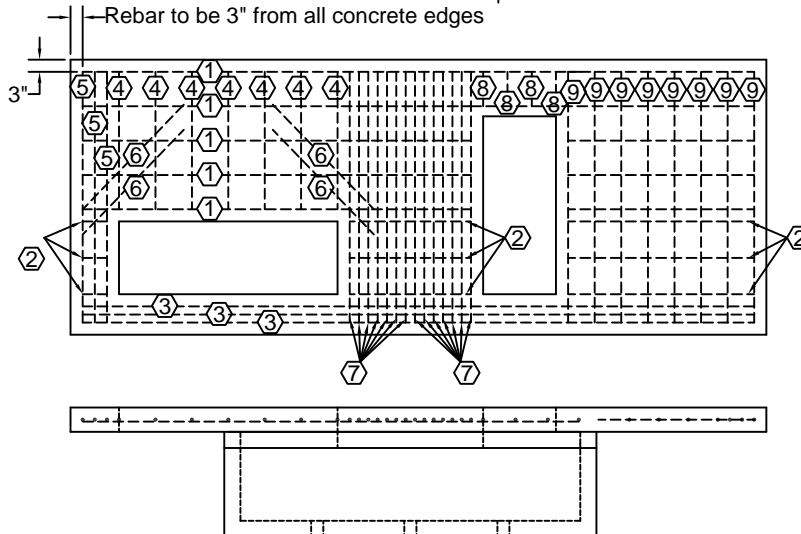
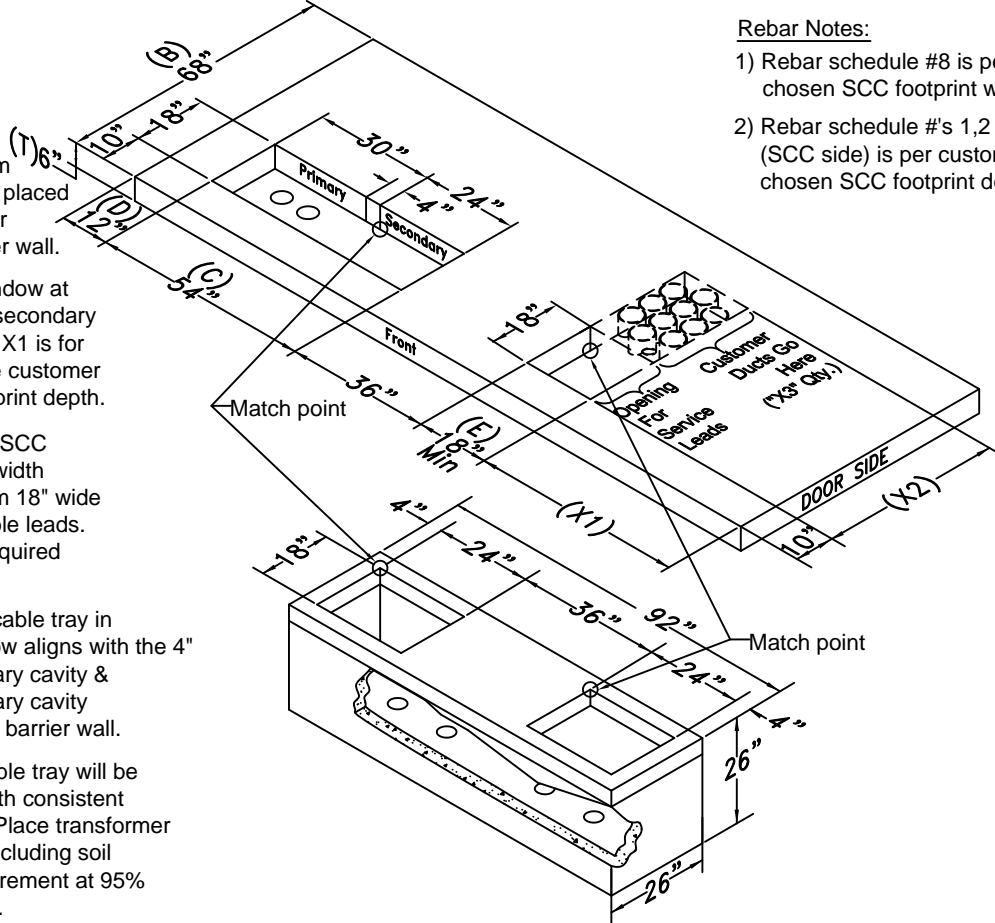

DRAWING CC-50B

SECONDARY CONNECTION CABINET AND TRANSFORMER POURED-IN-PLACE PAD 15 / 25 kV for 750-2500 kVa & 35 kV for 1500-2500 kVA In-Line Orientation-Preferred

15 & 25 kV 750-2500 kVA 35kV 1500-2500	PAD DIMENSIONS (DIM)							REINFORCED STEEL SCHEDULE									
	A	B	C	D	E	F	T	X1	①	②	③	④	⑤	⑥	⑦	⑧	⑨
104" See note 1	100"	64"	20"	18" Min	36"	8"	Bal of SCC width		9-#4	3-#4	3-#4	8-#4	6-#4	2-#4 x 3'0"	14-#4	5-#4	#4

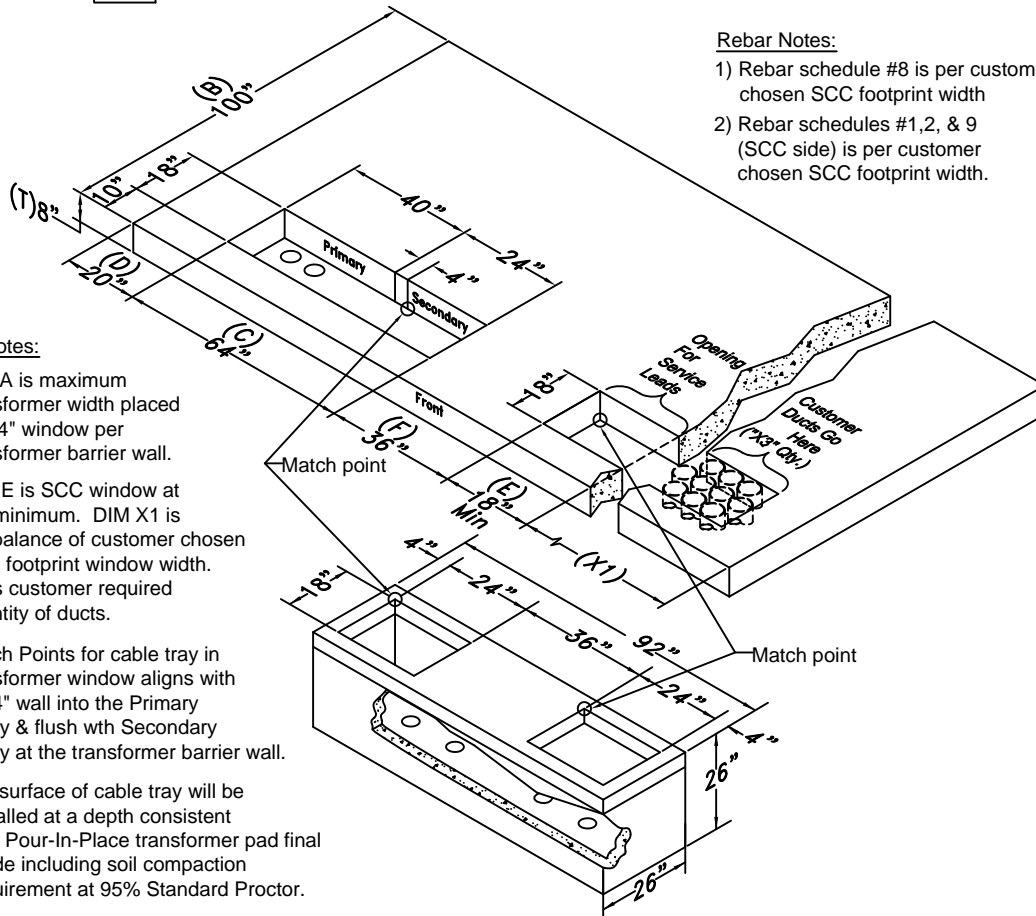

Rebar Notes:

- 1) Rebar schedule #8 is per customer chosen SCC footprint width
- 2) Rebar schedules #1,2, & 9 (SCC side) is per customer chosen SCC footprint width.

Pad Notes:

- 1) DIM A is maximum transformer width placed on 64" window per transformer barrier wall.
- 2) DIM E is SCC window at 18" minimum. DIM X1 is the balance of customer chosen SCC footprint window width. X3 is customer required quantity of ducts.
- 3) Match Points for cable tray in transformer window aligns with the 4" wall into the Primary cavity & flush with Secondary cavity at the transformer barrier wall.
- 4) Top surface of cable tray will be installed at a depth consistent with Pour-In-Place transformer pad final grade including soil compaction requirement at 95% Standard Proctor.
- 5) Two 6" - 36" radius conduit elbows for primary cable to extend 3' beyond the front edge of transformer pad.

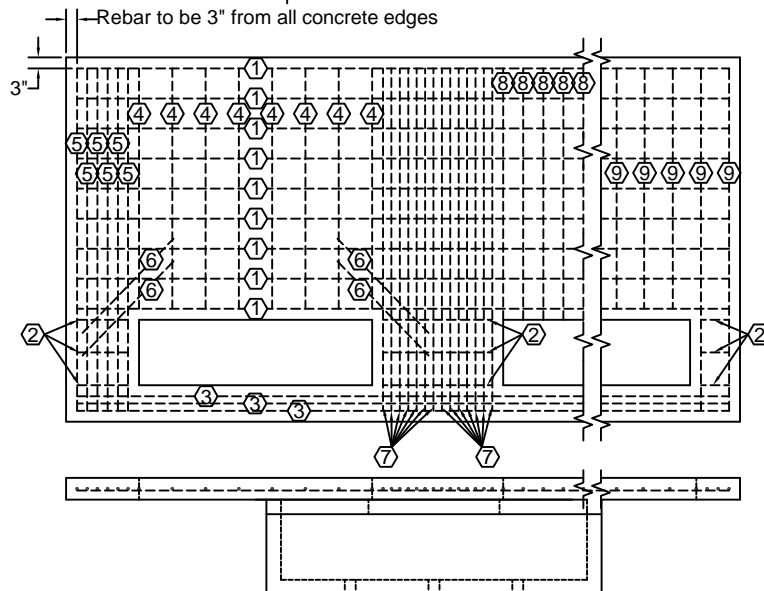

DRAWING CC-50D

SECONDARY CONNECTION CABINET AND TRANSFORMER POURED-IN-PLACE PAD 35 kV for 75-1000 kVA In-Line Orientation-Preferred

35 kV 75-1000 kVA	PAD DIMENSIONS (DIM)							REINFORCED STEEL SCHEDULE									
	A	B	C	D	E	F	T	X1	①	②	③	④	⑤	⑥	⑦	⑧	⑨
100" See note 1	75"	70"	15"	18" Min	36"	8"	Bal of SCC depth		6-#4	3-#4	3-#4	9-#4	4-#4	2-#4 x 3'0"	14-#4	4-#4	#4

Pad Notes:

- DIM A is maximum transformer width placed on 70" window per transformer barrier wall.
- DIM E is SCC window at 18" minimum for secondary cable leads X 18" deep. DIM X1 is balance of overall customer chosen SCC footprint width. X3 is customer required quantity of ducts.
- Match Points for cable tray in transformer window aligns with the 4" OD of the wall flush with the Secondary cavity at the transformer barrier wall.
- Top surface of cable tray will be installed at a depth consistent w/Pour-In-Place transformer pad final grade including soil compaction requirement at 95% Standard Proctor.
- Two 6" - 36" radius conduit elbows for primary cable to extend 3' beyond the front edge of transformer pad.

Rebar Notes:

- Rebar schedule #8 is per customer chosen SCC footprint width
- Rebar schedules for #1, 2, 9 on SCC side is per customer chosen SCC footprint width.

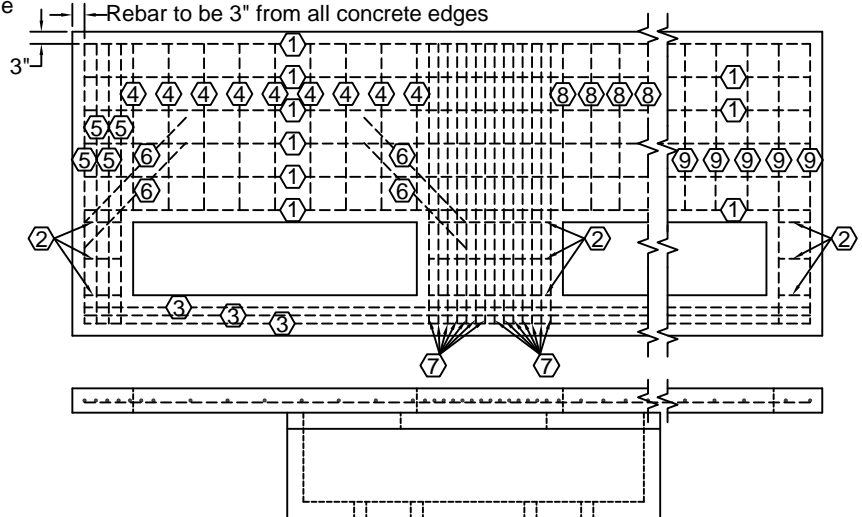
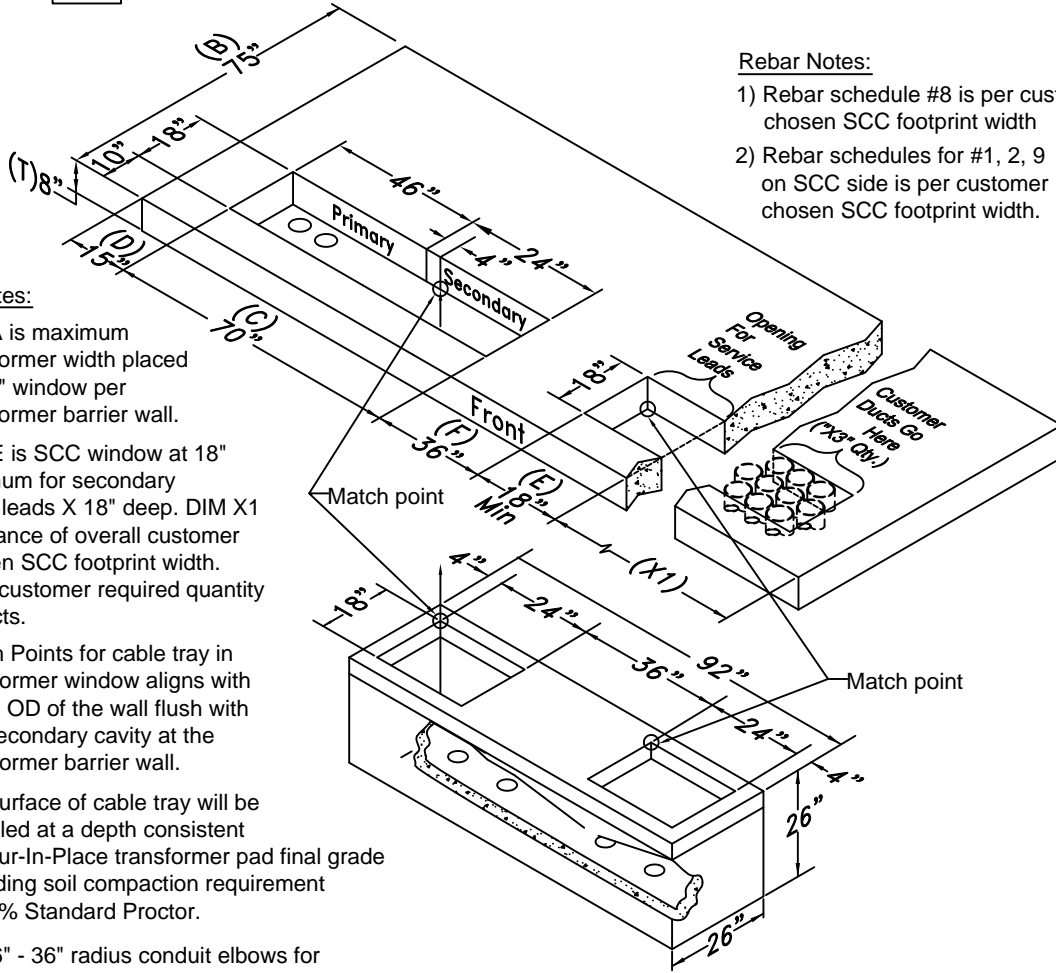

DRAWING CC-50E

SECONDARY CONNECTION CABINET AND TRANSFORMER POURED-IN-PLACE PAD 35 kV for 75-1000 kVA 90° Orientation

35 kV 75-1000 kVA		PAD DIMENSIONS (DIM)							REINFORCED STEEL SCHEDULE									
		A	B	C	D	E	F	T	X1	X2	①	②	③	④	⑤	⑥	⑦	⑧
100" See note 1		75"	70"	15"	18" Min	36"	8"	Bal of SCC depth	Bal of SCC width	6-#4	3-#4	3-#4	9-#4	4-#4	2-#4 x 3'0"	14-#4	4-#4	#4

Pad Notes:

- DIM A is maximum transformer width placed on 70" window per transformer barrier wall.
- DIM E is SCC window at 18" minimum for secondary cable leads. DIM X1 is for balance of customer chosen SCC footprint depth.
- DIM X2 is overall SCC footprint window width including minimum 18" wide for secondary cable leads. X3 is customer required quantity of ducts.
- Match Points for cable tray in transformer window aligns with the 4" OD of the wall flush with the Secondary cavity at the transformer barrier wall.
- Top surface of cable tray will be installed at a depth consistent with the Pour-In-Place transformer pad final grade including soil compaction requirement at 95% Standard Proctor.
- Two 6" - 36" radius conduit elbows for primary cable to extend 3' beyond the front edge of transformer pad.

Rebar Notes:

- Rebar schedule #8 is per customer chosen SCC footprint width
- Rebar schedules for #1,2, 9 on SCC side is per customer chosen SCC footprint depth.

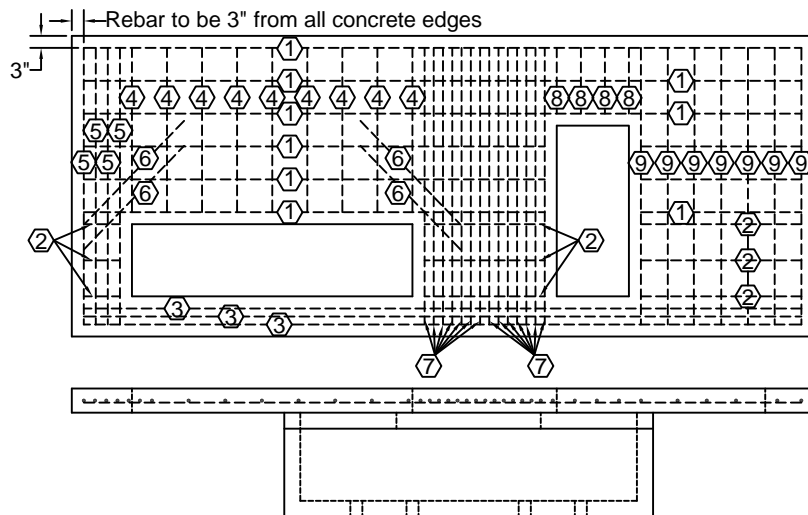
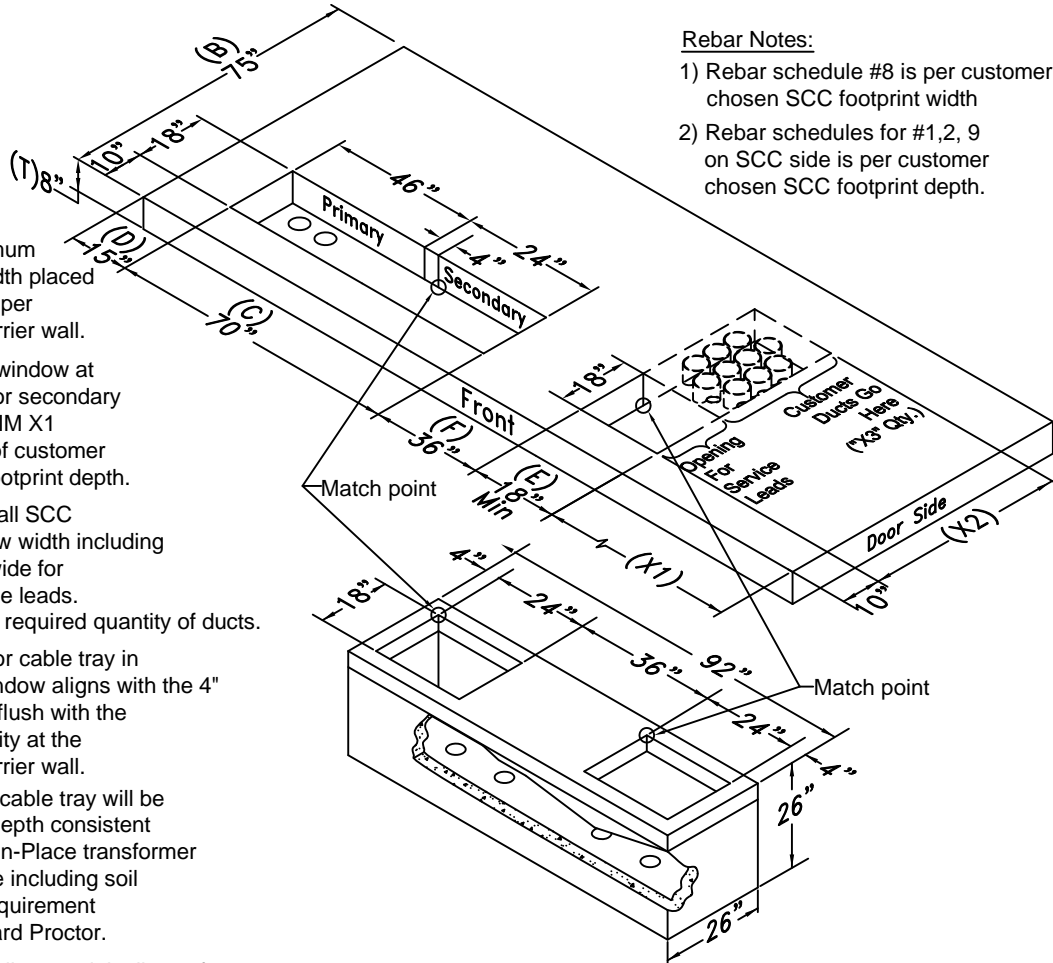

This Page Intentionally Left Blank

TABLE OF RESPONSIBILITY

Drawing CC-60, 60A, B, C, D & E

ITEM, MATERIAL OR WORK DESCRIPTION	PARTY TO FURNISH, OWN AND MAINTAIN	PARTY TO INSTALL
Permits and Inspections	Customer	N/A
Conductors from Transformer to Secondary Connection Cabinet (SCC)	Company	Company
SCC Line Side Termination Lugs	Company	Company
Transformer Pour-In-Place Concrete Pad	Customer	Customer
Secondary Connection Cabinet (SCC)	Customer	Customer
SCC Load Side Conduit, Sweeps and Conductor	Customer	Customer
SCC Ground Rod, Conductor to neutral bus and Case Ground	Customer	Customer
2 - 6", 36" Radius Conduit Elbows for Primary Cable	Customer	Customer

DRAWING CC-60

TRANSFORMER PAD DIMENSIONS FOR POURED-IN-PLACE

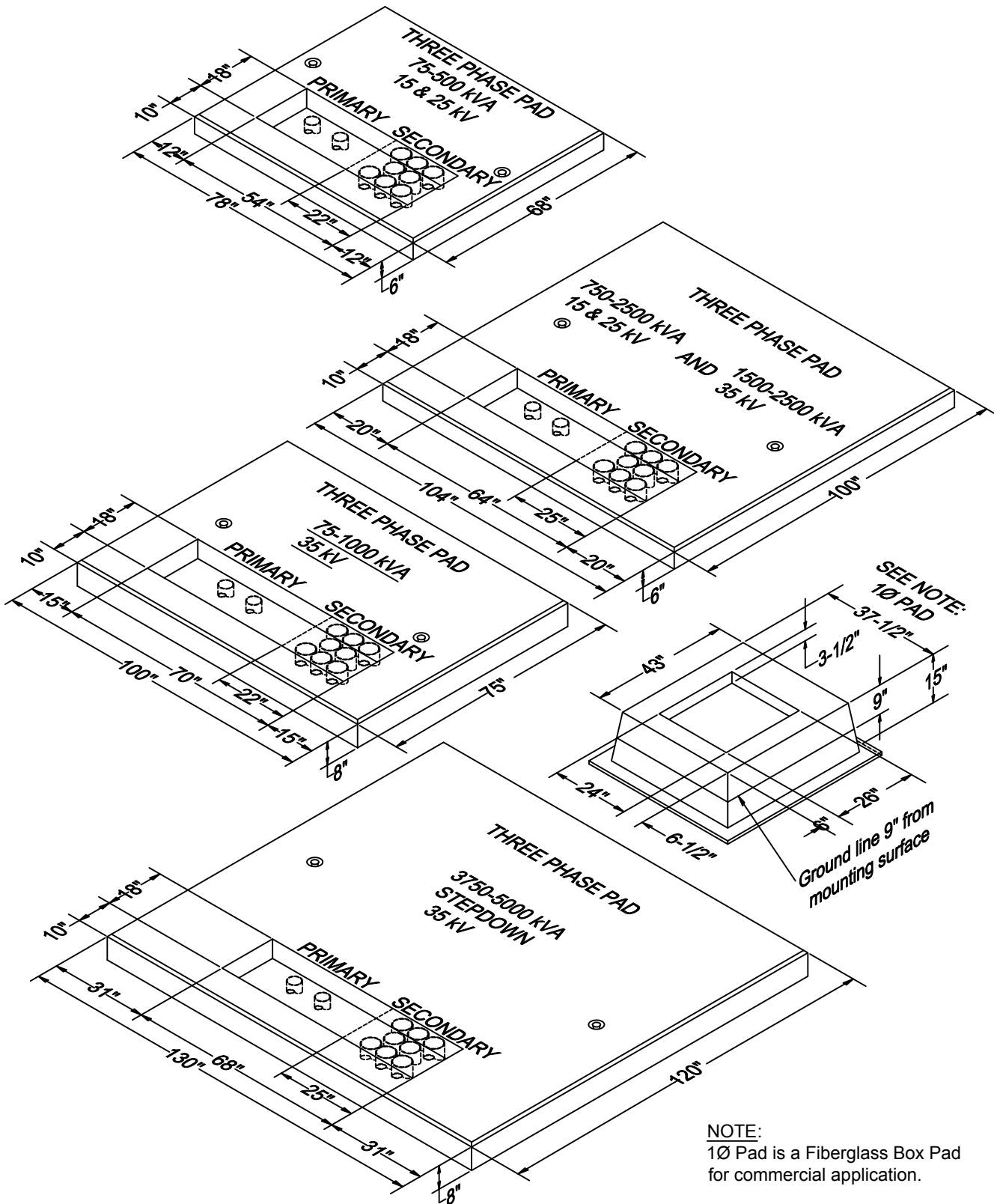

NOTE:
1Ø Pad is a Fiberglass Box Pad
for commercial application.

DRAWING CC-60A

THREE PHASE TRANSFORMER CONCRETE PAD 15 AND 25 kV (75-500 kVA) POURED IN PLACE

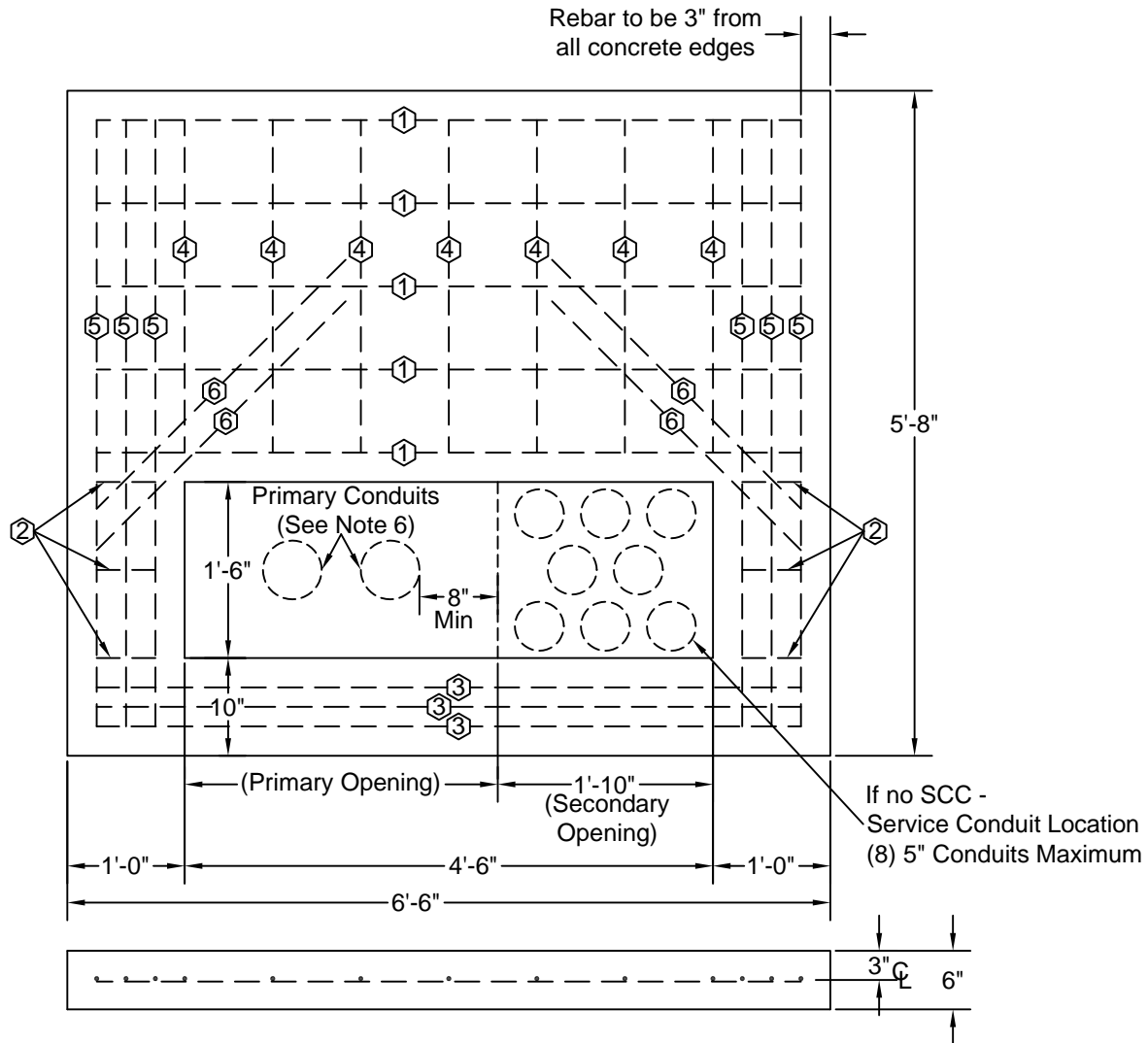

REINFORCING STEEL SCHEDULE

①	②	③	④	⑤	⑥	Approx. Weight
(5) #4 X 6'-0"	(6) #4 X 0'-6"	(3) #4 X 6'-0"	(7) #4 X 2'-10"	(6) #4 X 5'-2"	(4) #4 X 3'-0"	2300 lbs.

NOTES:

1. Concrete shall have a minimum compressive strength of 3000 psi at 28 days. All concrete shall be air entrained (4% to 6% by volume) with a maximum W/C ratio of 0.45.
2. Reinforcing steel shall be furnished in accordance with ASTM A615 Grade 60. Place per schedule within the limits shown. All reinforcing steel shall be uniformly tied to reinforcing steel to prevent displacement during concrete placement.
3. Top surface finish shall be level. Wood float top; do not leave any depressions.
4. Soil compaction under pad (for both pour-in-place and separate standard pads) to be at 95% Standard Proctor.
5. Pad must be located within 10 feet of driving surface for truck access for placement of transformer.
6. Two 6" - 36" radius conduit elbows for primary cable to extend 3' beyond the front edge of transformer pad.

DRAWING CC-60B

THREE PHASE TRANSFORMER CONCRETE PAD 15 AND 25 kV (750-2500 kVA) POURED IN PLACE

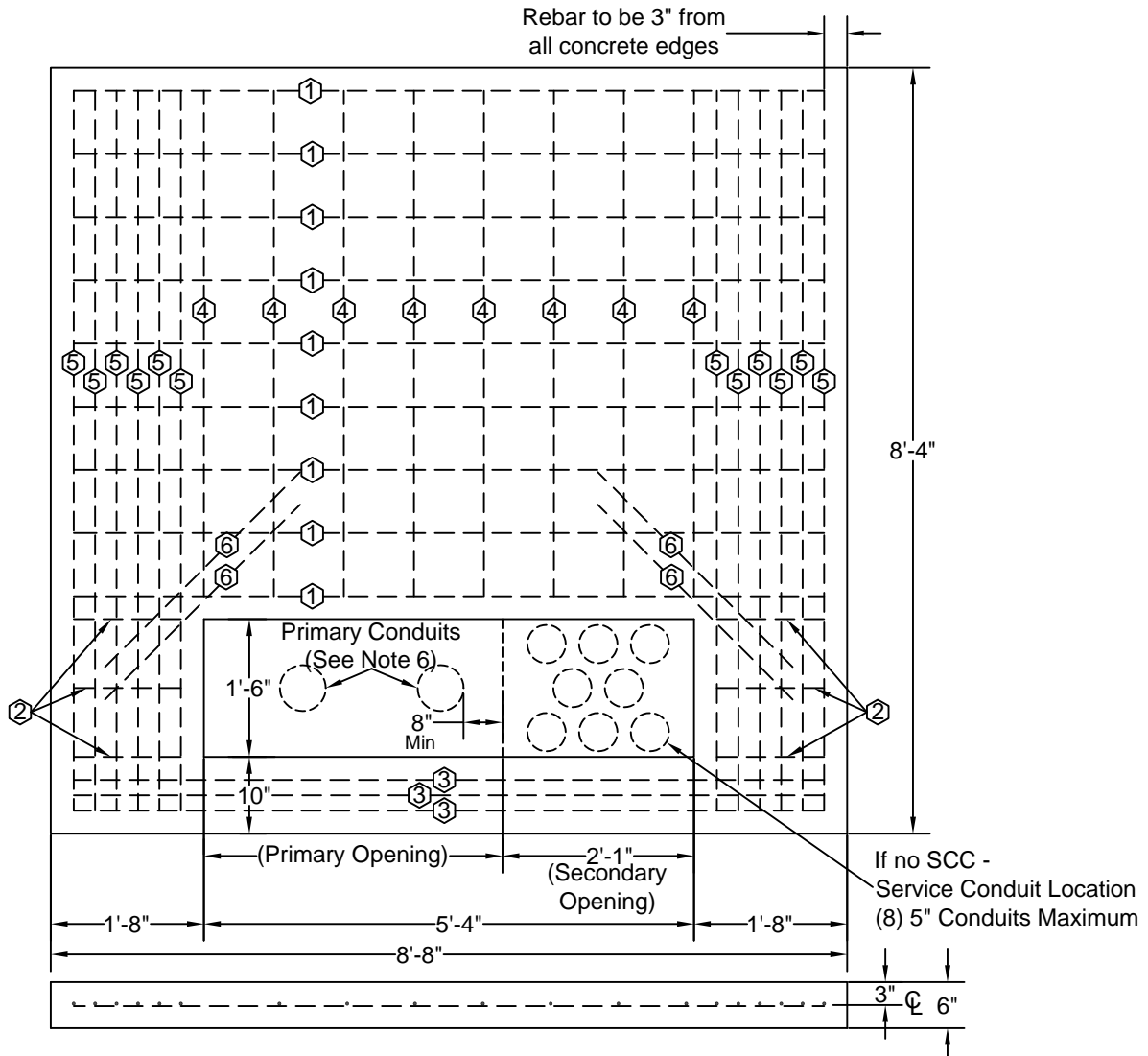

REINFORCING STEEL SCHEDULE						
①	②	③	④	⑤	⑥	Approx. Weight
(9) #4 X 8'-2"	(6) #4 X 1'-2"	(3) #4 X 8'-2"	(8) #4 X 5'-6"	(12) #4 X 7'-10"	(4) #4 X 3'-0"	6500 lbs.

NOTES:

- Concrete shall have a minimum compressive strength of 3000 psi at 28 days. All concrete shall be air entrained (4% to 6% by volume) with a maximum W/C ratio of 0.45.
- Reinforcing steel shall be furnished in accordance with ASTM A615 Grade 60. Place per schedule within the limits shown. All reinforcing steel shall be uniformly tied to reinforcing steel to prevent displacement during concrete placement.
- Top surface finish shall be level. Wood float top; do not leave any depressions.
- Soil compaction under pad (for both pour-in-place and separate standard pads) to be at 95% Standard Proctor.
- Pad must be located within 10 feet of driving surface for truck access for placement of transformer.
- Two 6" - 36" radius conduit elbows for primary cable to extend 3' beyond the front edge of transformer pad.

DRAWING CC-60C

THREE PHASE TRANSFORMER CONCRETE PAD 35 KV (75-1000 KVA) POURED IN PLACE

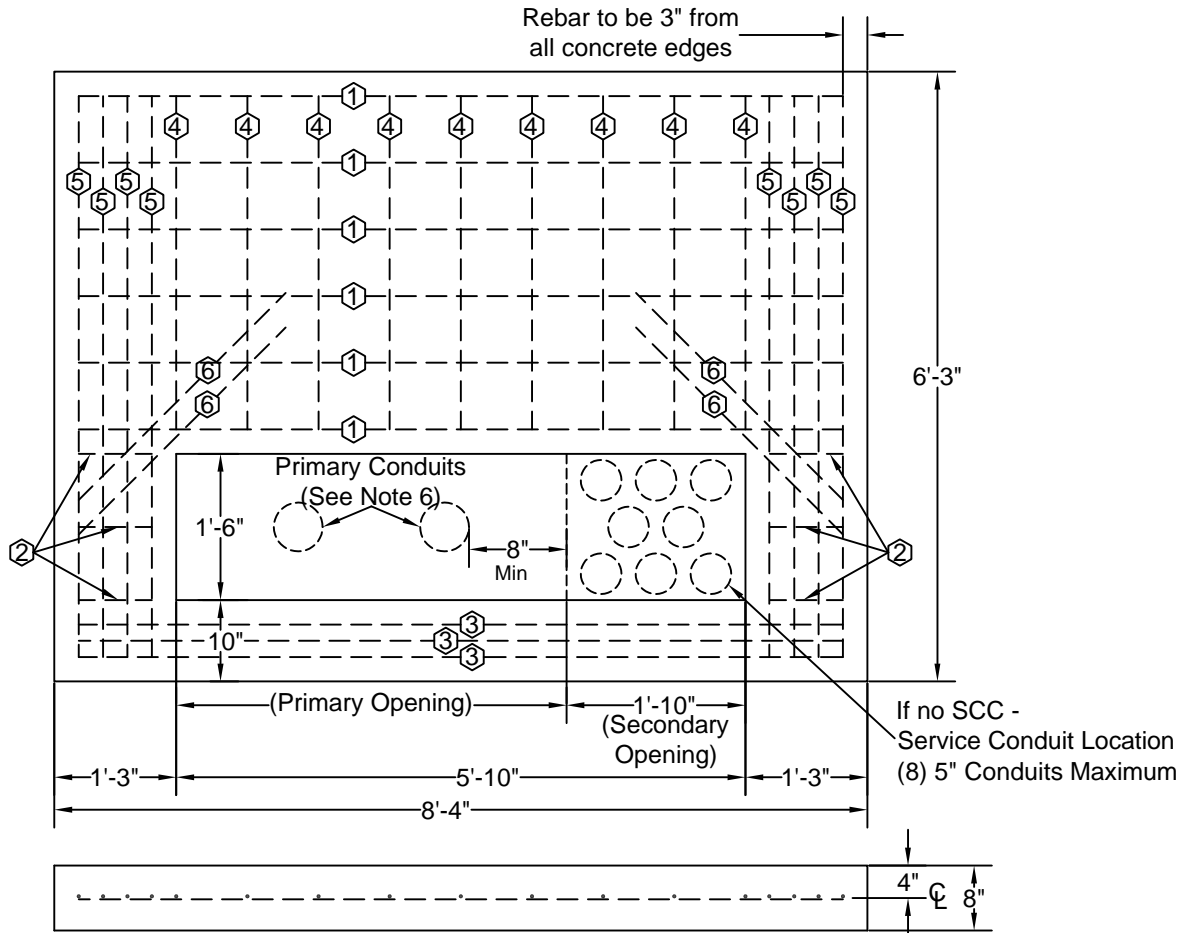

REINFORCING STEEL SCHEDULE

①	②	③	④	⑤	⑥	Approx. Weight
(6) #4 X 7'-10"	(6) #4 X 0'-9"	(3) #4 X 7'-10"	(9) #4 X 3'-5"	(8) #4 X 5'-9"	(4) #4 X 3'-0"	4400 lbs.

NOTES:

- Concrete shall have a minimum compressive strength of 3000 psi at 28 days. All concrete shall be air entrained (4% to 6% by volume) with a maximum W/C ratio of 0.45.
- Reinforcing steel shall be furnished in accordance with ASTM A615 Grade 60. Place per schedule within the limits shown. All reinforcing steel shall be uniformly tied to reinforcing steel to prevent displacement during concrete placement.
- Top surface finish shall be level. Wood float top; do not leave any depressions.
- Soil compaction under pad (for both pour-in-place and separate standard pads) to be at 95% Standard Proctor.
- Pad must be located within 10 feet of driving surface for truck access for placement of transformer.
- Two 6" - 36" radius conduit elbows for primary cable to extend 3' beyond the front edge of transformer pad.

DRAWING CC-60D

THREE PHASE TRANSFORMER CONCRETE PAD 35 kV (1500-2500 kVA) POURED IN PLACE

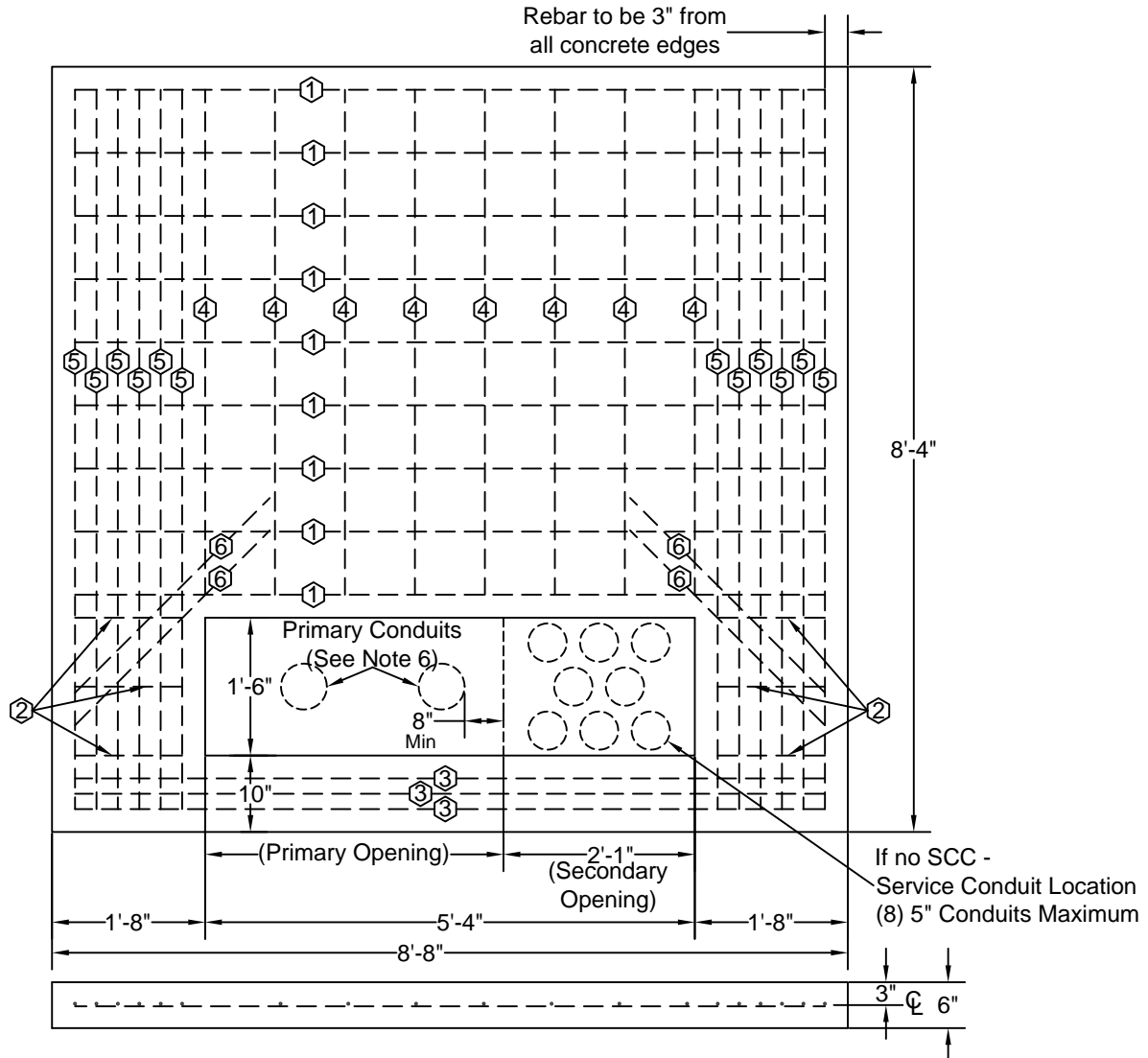

REINFORCING STEEL SCHEDULE						
①	②	③	④	⑤	⑥	Approx. Weight
(9) #4 X 8'-2"	(6) #4 X 1'-2"	(3) #4 X 8'-2"	(8) #4 X 5'-6"	(12) #4 X 7'-10"	(4) #4 X 3'-0"	6500 lbs.

NOTES:

- Concrete shall have a minimum compressive strength of 3000 psi at 28 days. All concrete shall be air entrained (4% to 6% by volume) with a maximum W/C ratio of 0.45.
- Reinforcing steel shall be furnished in accordance with ASTM A615 Grade 60. Place per schedule within the limits shown. All reinforcing steel shall be uniformly tied to reinforcing steel to prevent displacement during concrete placement.
- Top surface finish shall be level. Wood float top; do not leave any depressions.
- Soil compaction under pad (for both pour-in-place and separate standard pads) to be at 95% Standard Proctor.
- Pad must be located within 10 feet of driving surface for truck access for placement of transformer.
- Two 6" - 36" radius conduit elbows for primary cable to extend 3' beyond the front edge of transformer pad.

DRAWING CC-60E

THREE PHASE TRANSFORMER CONCRETE PAD 35 kV (3750-5000 kVA STEPDOWN) POURED IN PLACE

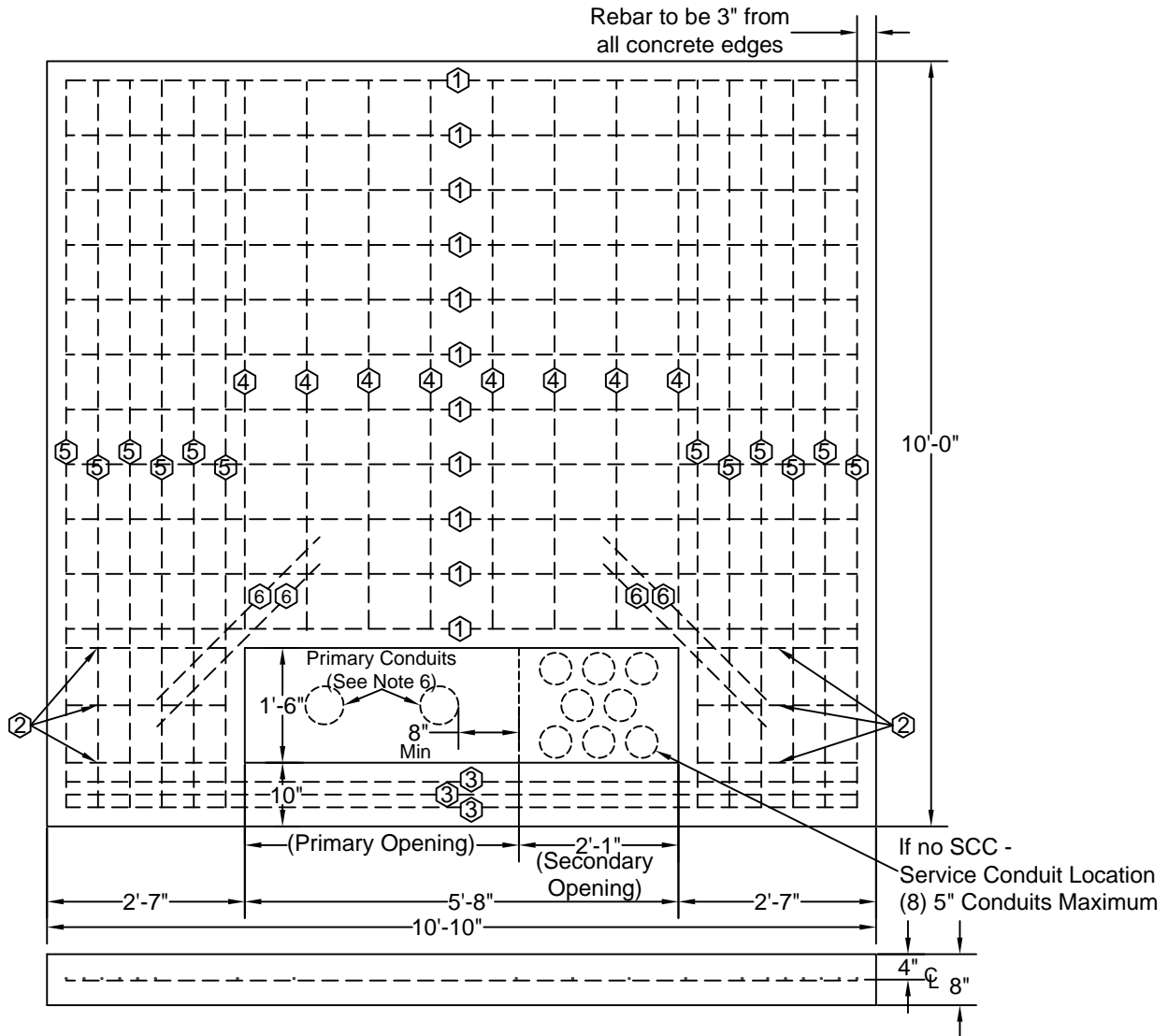

REINFORCING STEEL SCHEDULE						
①	②	③	④	⑤	⑥	Approx. Weight
(11) #4 X 10'-4"	(6) #4 X 2'-1"	(3) #4 X 10'-4"	(8) #4 X 7'-2"	(12) #4 X 9'-6"	(4) #4 X 3'-0"	10,100 lbs.

NOTES:

- Concrete shall have a minimum compressive strength of 3000 psi at 28 days. All concrete shall be air entrained (4% to 6% by volume) with a maximum W/C ratio of 0.45.
- Reinforcing steel shall be furnished in accordance with ASTM A615 Grade 60. Place per schedule within the limits shown. All reinforcing steel shall be uniformly tied to reinforcing steel to prevent displacement during concrete placement.
- Top surface finish shall be level. Wood float top; do not leave any depressions.
- Soil compaction under pad (for both pour-in-place and separate standard pads) to be at 95% Standard Proctor.
- Pad must be located within 10 feet of driving surface for truck access for placement of transformer.
- Two 6" - 36" radius conduit elbows for primary cable to extend 3' beyond the front edge of transformer pad.

DRAWING CR-10

CLEARANCE REQUIREMENTS FROM GAS METER

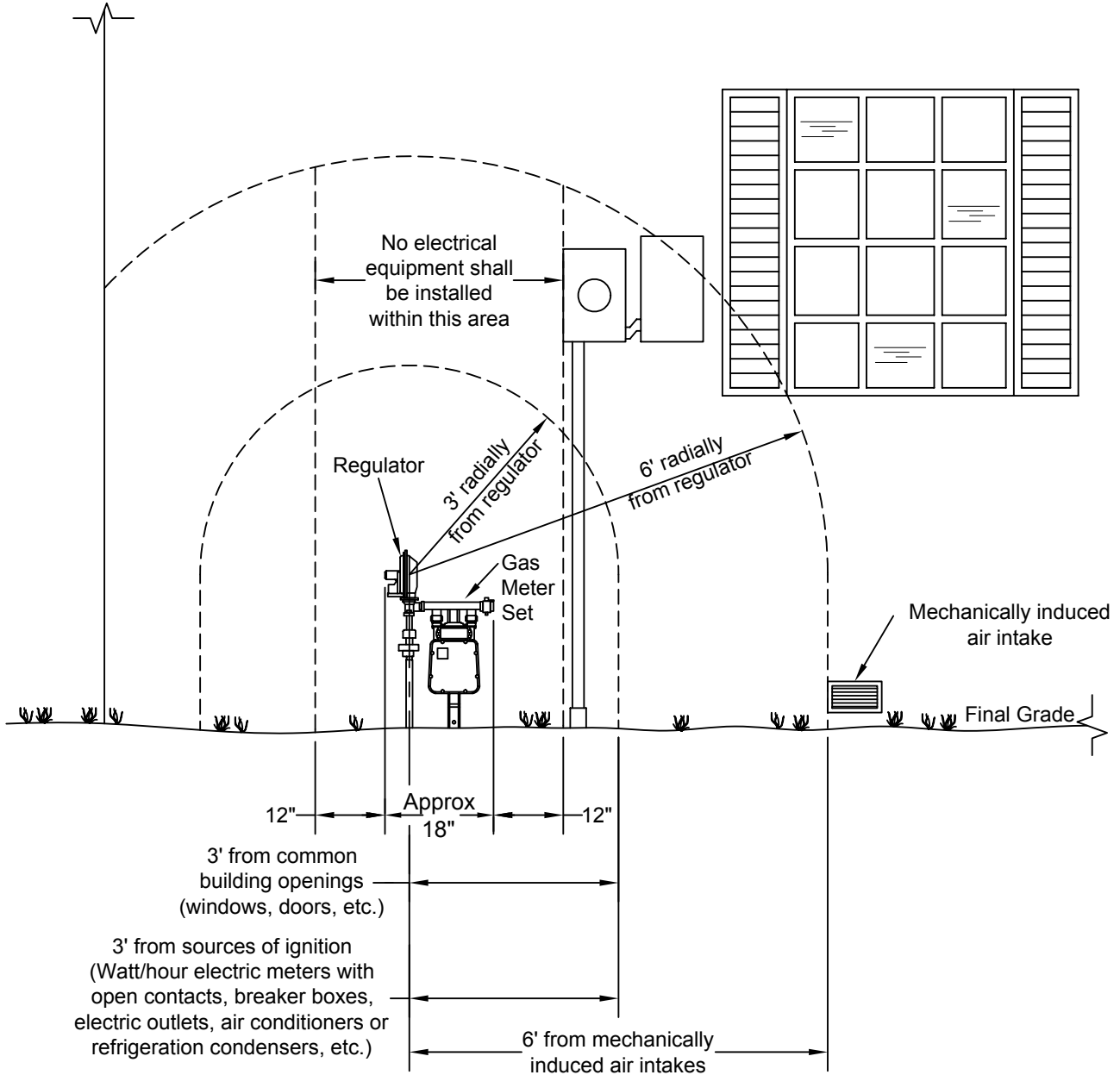

NOTES:

1. 3' minimum working clearance from non-electrical obstructions is preferred around gas meter set.
2. Disregard clearances when measuring around corners of structure.
3. See [Sections 4.2.1\(4\)](#), [4.3.1\(3\)](#), and drawings [SC-20](#) and [SC-20A](#) for ice and snow shield requirements.
4. Plastic gas services and electric services can be installed in the same joint trench; steel gas services are prohibited from joint trench installation with electric services. Also, gas and electric services shall have a minimum of 12" spacing, whether they are in the same trench or not

DRAWING CR-20

CLEARANCE REQUIREMENTS FOR PROPANE TANKS AND OTHER COMBUSTIBLE SOURCES

All electric distribution equipment installations shall meet or exceed the minimum requirements for Class I hazardous locations (see NESC 127, NEC Article 514, and NEC Article 515).

Underground cables shall not be installed under any type of fuel tank. Cables shall not come within 10 feet of above or below-ground tanks.

Ground rods should be located 10 ft or more from fuel pipelines or high pressure gas lines. For facilities closer than 10 ft, notify the cathodic protection group for evaluation. (NESC095B2)

Electric Distribution equipment shall not be installed any closer than 6 feet radially to any generators or customer owned transformers, to eliminate touch potentials between enclosures.

Class I Hazardous Locations

Buried electric lines, meter sockets, CT cabinets, or termination enclosures must observe the following minimum horizontal clearances from the flammable fuel system components listed below:

Under fuel storage tanks	Not Permitted
Fill Pipe	10 ft
Dispensing device	20 ft
Remote pump	10 ft
Vents	5 ft

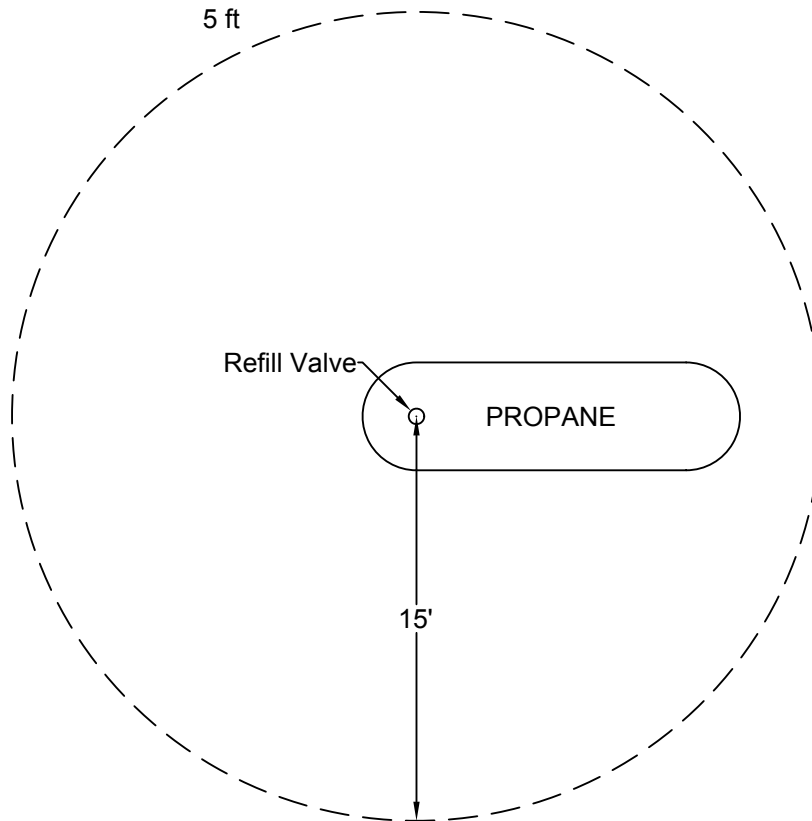

**NO PADMOUNT EQUIPMENT OR ELECTRIC METER SHALL BE INSTALLED
WITHIN 15 FT OF THE REFILL VALVE OF A TANK CONTAINING PROPANE.**

Notes:

1. The local Area Engineer should be contacted when violations are noted.
2. The Area Engineer will contact the appropriate governmental agency to report violation.

DRAWING CR-30

CLEARANCES FOR OIL FILLED EQUIPMENT LOCATED NEAR BUILDINGS

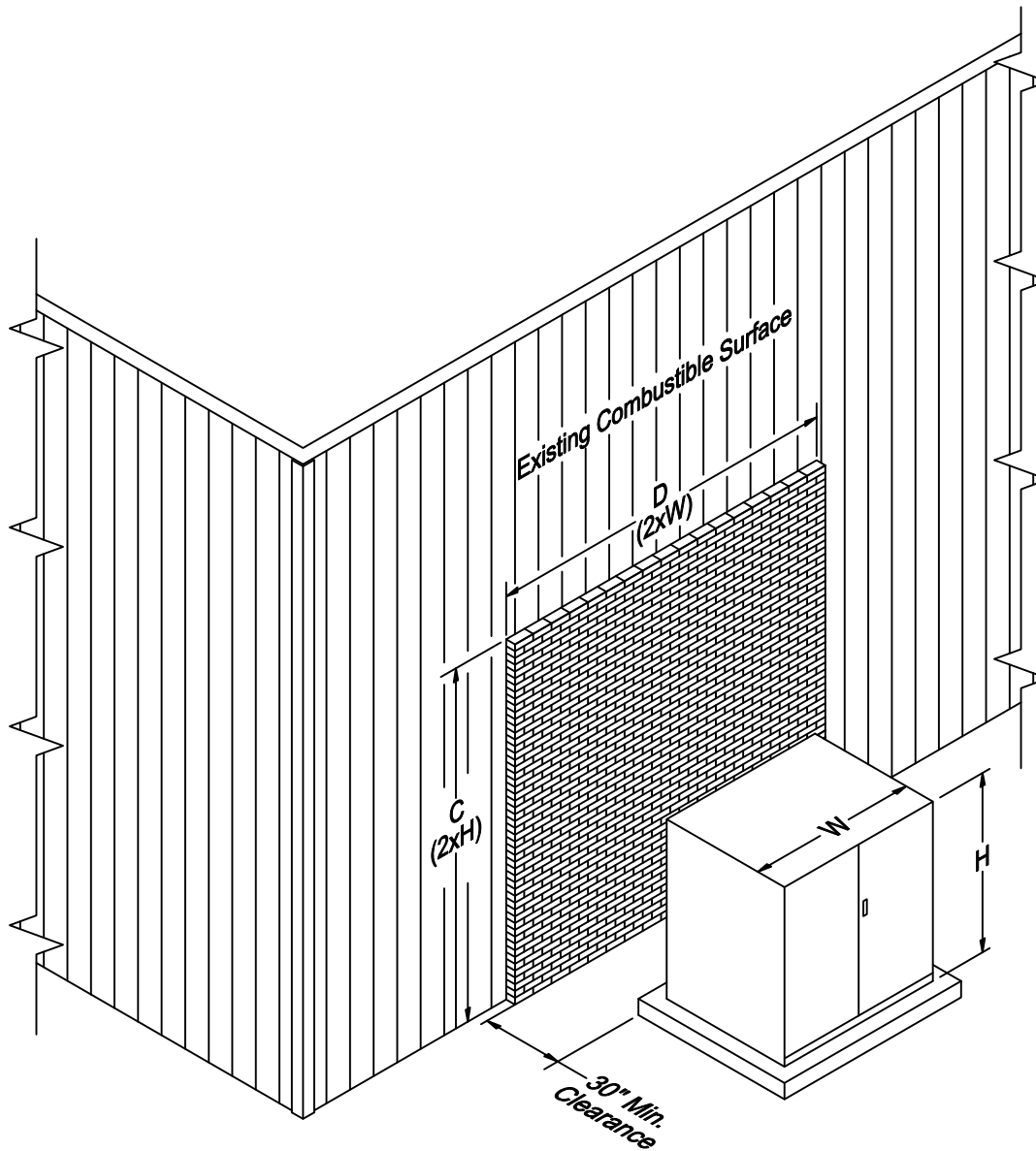

Fire Resistant Barriers Attached Directly To Wall

In locations where basic clearances cannot be met, a fire resistant barrier shall be installed either by the customer or at the customer's expense to reduce the required clearance to combustible walls, doors air intakes or windows. The barrier shall be constructed of non-combustible material certified to have a 2 hour fire rating. It shall be of sufficient strength and have stability to resist tipping and satisfy local building ordinances. If a specific ruling regarding fire ratings is necessary, contact the local fire protection district. Engineering will coordinate the construction and location of the barrier, however the customer is responsible for all maintenance. The barrier will satisfy the following dimensional requirements:

H = Height in inches of oil filled equipment.

W = Width in inches of oil filled equipment.

C = Height of barrier required to obtain a projected height of two times the height of the oil filled equipment on the building wall (2xH).

D = Width of barrier required to obtain a projected width of two times the width of the oil filled equipment on the building wall (2xW) .

DRAWING CR-30A

LOCATION OF PAD-MOUNTED TRANSFORMERS

- I. NONCOMBUSTIBLE WALLS (Included in this class would be wood framed brick veneered buildings, metal clad steel framed buildings, asbestos-cement-board walled metal framed buildings and masonry buildings and masonry buildings with a one hour fire rating.)

Oil insulated, pad-mounted transformers may be located a minimum distance of 30" from noncombustible walls if all the following clearances are maintained from doors, windows, and other building openings. A sump shall be installed for transformers if the immediate terrain is not pitched away from the building.

Contact Electric Standards for sump specifications. If a combustible first floor overhang exists, a 10' distance from the edge of the transformer to the edge of the overhang shall be required in addition to the other clearances shown.

A. DOORS

Oil insulated, pad-mounted transformers shall not be located within a zone extending 20' outward and 10' to either side of a building door.

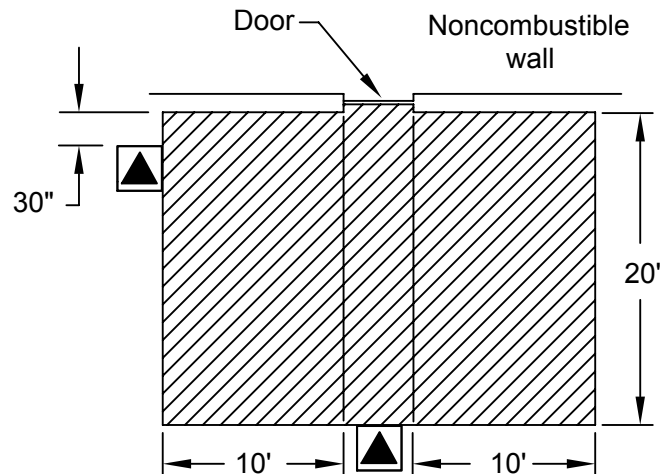

B. AIR INTAKE OPENINGS

Oil insulated, pad-mounted transformers shall not be located within a zone extending 10' outward and 10' to either side of an air intake opening located within 10' of the ground. If the air intake opening is located more than 10' above the ground, the distance from the transformer to the opening shall be a minimum of 25'.

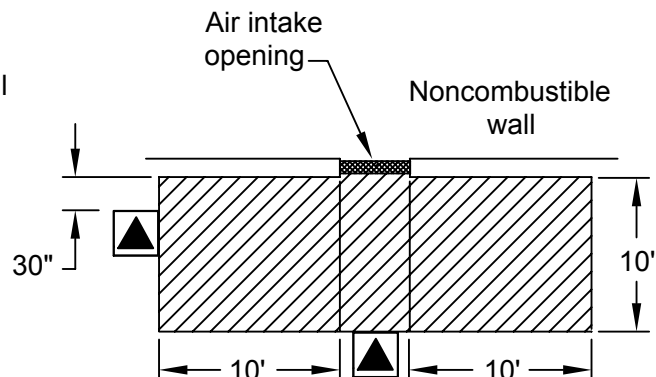

DRAWING CR-40

LOCATION OF PAD-MOUNTED TRANSFORMERS NEAR BUILDINGS

C. WINDOWS OR OPENINGS OTHER THAN AIR INTAKE

1. First Story

Oil insulated pad-mounted transformers shall not be located within a zone extending 10' outward and 3' to either side of a building window or opening other than an air intake.

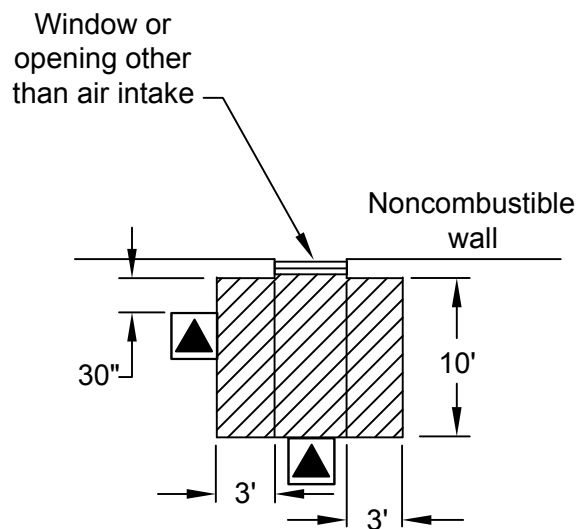

2. Second Story

Oil insulated, pad-mounted transformers shall not be located less than 5' from any part of a second story window or opening other than an air intake.

Oil filled equipment shall not be placed below an operating window on any floor.
No exceptions will be made!

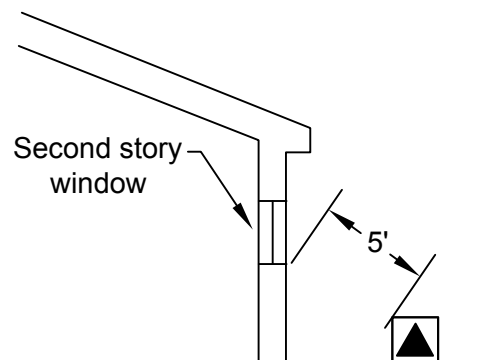

DRAWING CR-50

LOCATION OF PAD-MOUNTED TRANSFORMERS NEAR BUILDINGS

II. COMBUSTIBLE WALLS

(Included in this class would be wood buildings and metal clad buildings with wood frame construction.) Oil insulated, pad-mounted transformers shall be located a minimum 10' from the building wall in addition to the clearance from building doors, windows, and other openings set forth for noncombustible walls. A sump shall be installed for transformers if the immediate terrain is not pitched away from the building. Contact Customer Service and Technical Support for sump specifications. If a combustible first floor overhang exists, a 10' distance from the edge of the transformer to the edge of the overhang (combination of vertical and horizontal distance) shall be required in addition to the other clearances as shown.

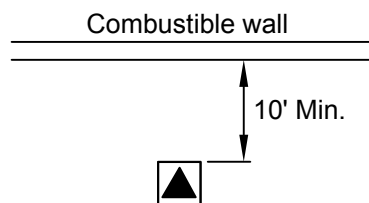

III. BARRIERS (Included in this class are reinforced concrete, brick, or concrete block barrier walls with a 3 hour fire rating.) If the clearance specified above cannot be obtained, a fire resistant barrier shall be constructed in lieu of the separation. The barrier (when required) is provided by the customer. The following methods of construction are acceptable.

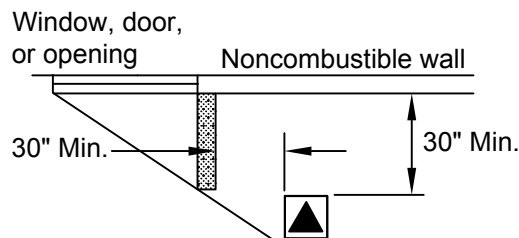

A. NONCOMBUSTIBLE WALLS

The barrier shall extend to a projection line from the corner of the pad-mounted to the furthest corner of the window, door, or opening in question.

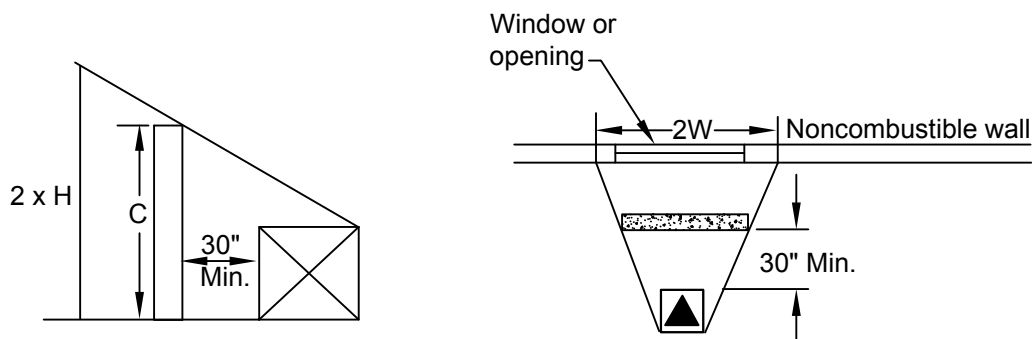

DRAWING CR-60

LOCATION OF PAD-MOUNTED TRANSFORMERS NEAR BUILDINGS

B. COMBUSTIBLE WALLS

The barrier shall extend 3' beyond each side of the oil insulated, pad-mounted transformer. The height of the barrier shall be 3' above the top of the pad-mounted transformer. If a combustible first floor overhang exists, the 24" specified shall be measured from the edge of the overhang rather than from the building wall.

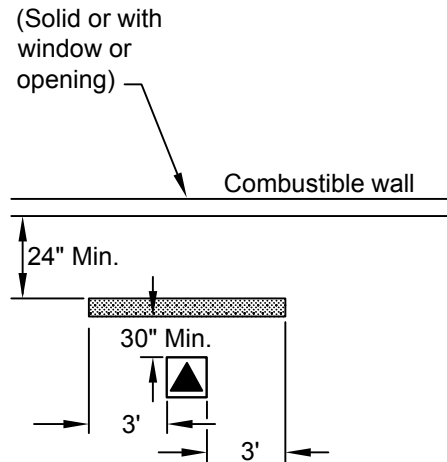

IV. FIRE ESCAPES

Oil insulated, pad-mounted transformers shall be located such that a minimum clearance of 20' is maintained from fire escapes at all times.

Exception: Oil insulated, pad-mounted transformers may be located closer to a fire escape than the 20' minimum when a fire resistant barrier is constructed around the transformer (side walls and roof). The barrier shall extend a minimum of 1' beyond the transformer. The transformer and barrier shall not in any way obstruct the fire escape exit. 10' clearance is required in front of padmount transformer doors. Adequate transformer accessibility and ventilation must be provided. If transformer is installed underneath a fire escape, maintain 10' vertical clearance.

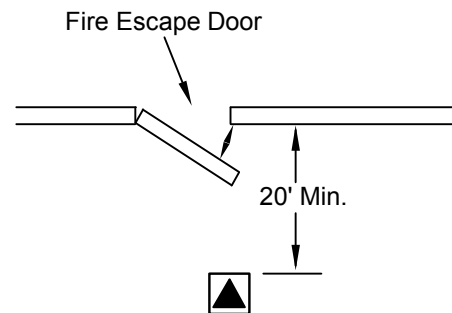

V. DECORATIVE COMBUSTIBLE ENCLOSURE

Decorative combustible enclosures (fence) installed by the customer around oil insulated, pad-mounted transformers adjacent to a combustible building wall shall not extend more than 24" beyond the transformer towards the combustible wall. 10' clearance required in front of pad-mounted transformer doors. Adequate transformer accessibility and ventilation must be provided.

VI. NONCOMBUSTIBLE AND COMBUSTIBLE WALLS - FIRE RESISTANT BARRIERS

The examples of combustible and noncombustible walls and fire resistant barriers obtained from March & McLennan Inc., Protection Consultants, and apply to building exposure to a fire located outside of the building.

DRAWING CR-70

CLEARANCE OF COMPANY OWNED SECONDARIES AND SERVICE DROPS

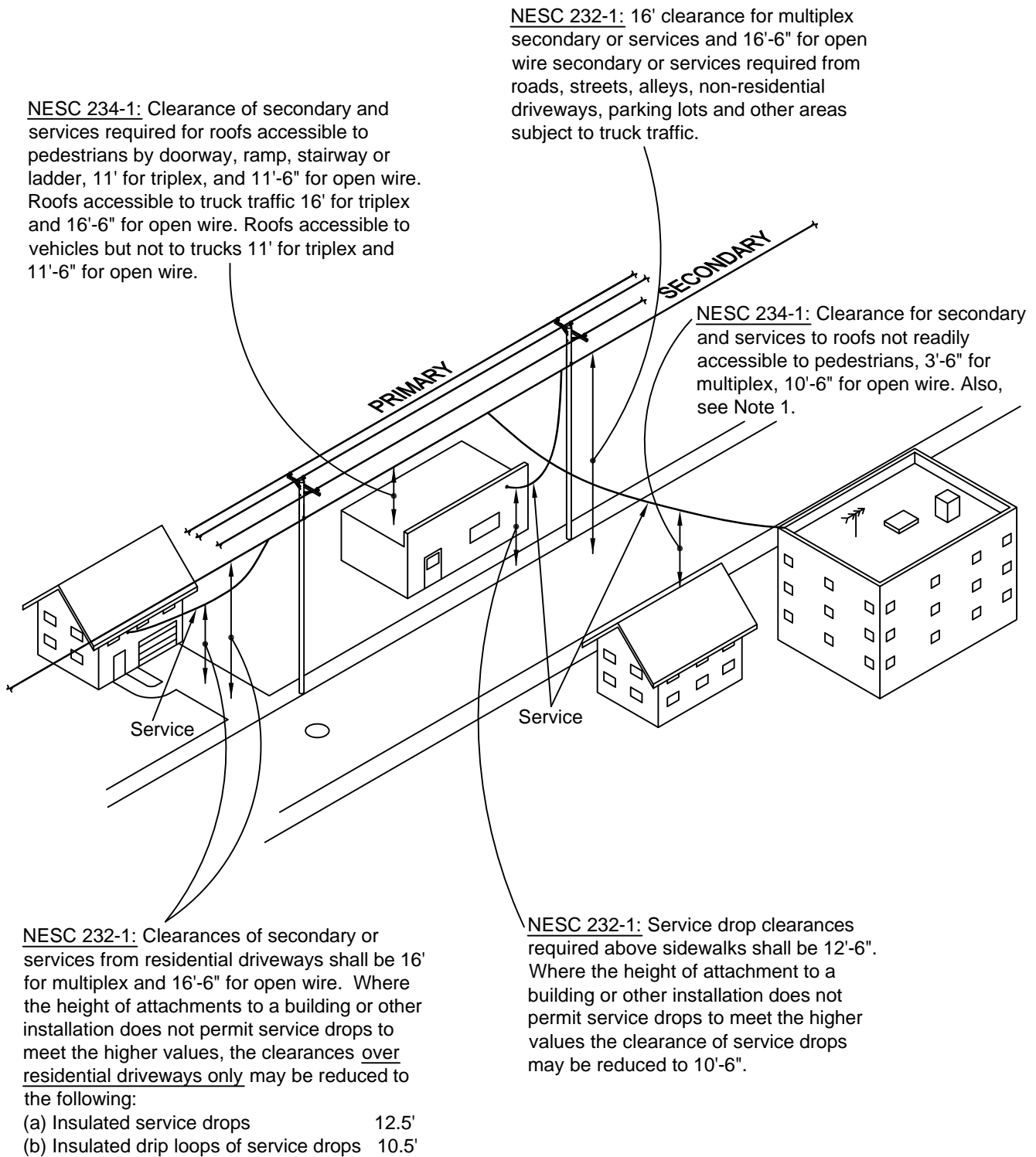

Notes:

1. Wisconsin State Electrical Code PSC 114.234. Wisconsin Only service conductors attached to buildings or other installation shall have a clearance of 8 ft. If the roof has a pitch of not less than 1 to 3, clearance may be reduced to 3 ft.

DRAWING CR-70A

CLEARANCE OF COMPANY OWNED SECONDARIES AND SERVICE DROPS

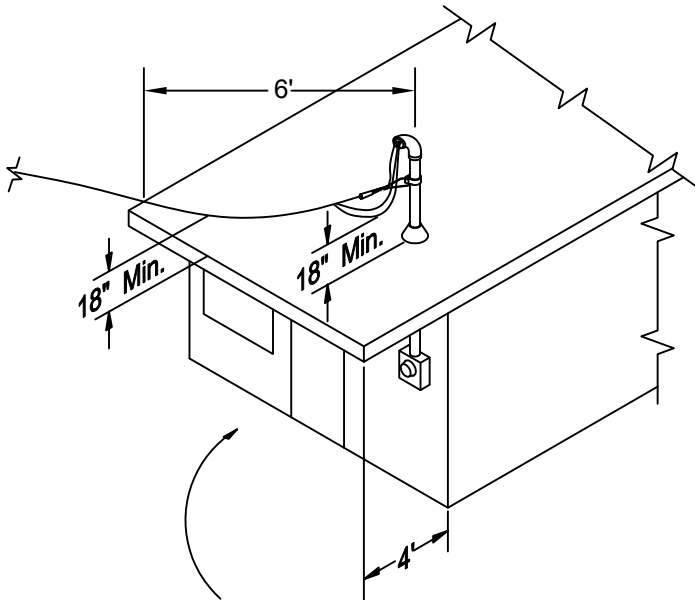

NESC 234-C-3 EXCEPTION #2: Where not more than 6' measured (horizontally) service drop of 300 volts or less may pass over 4' of overhang if a minimum of 18" of clearance is maintained. If the service crosses more than 6' of roof, then 3' of clearance is required after the first 6'

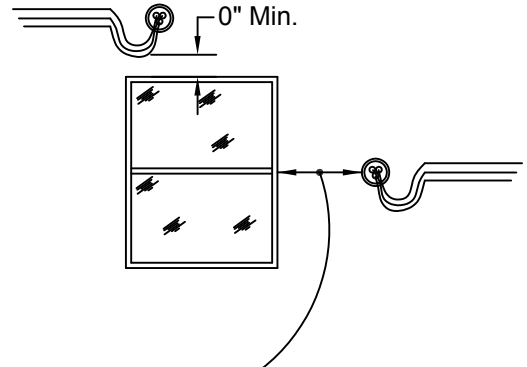

NESC 234-1: A horizontal clearance of not less than 3' for triplex and 5'-6" for open wire must be maintained from window. Above window a 0" vertical clearance is allowed.

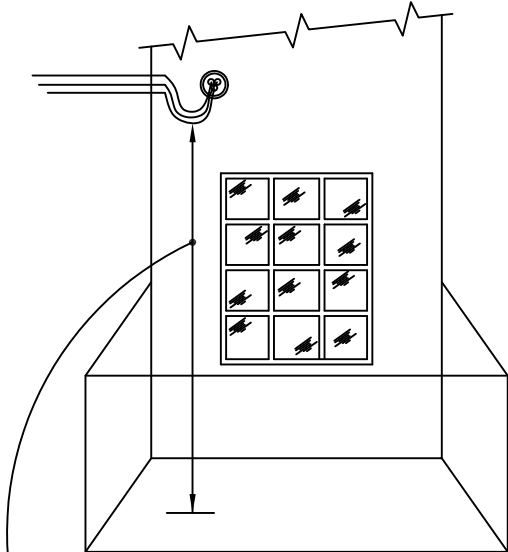

NESC 234-1: Open wire over 750 volts to ground 13'-6"; open wire up to 750 volts to ground 11'-5"; triplex/quad 11'-0".

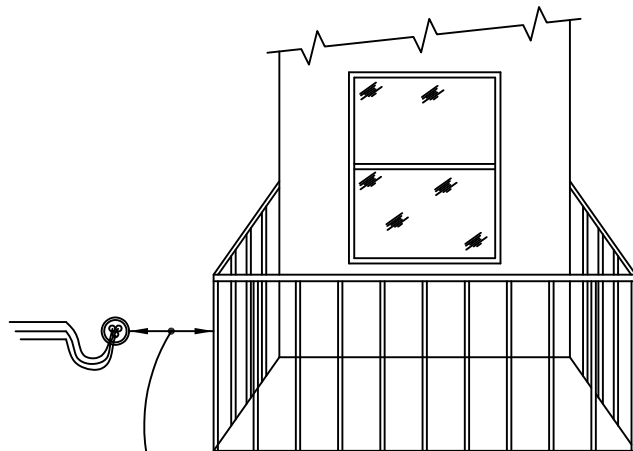

NESC 234-1: Conductors shall have a horizontal clearance of 3' for triplex and 5'-6" for open wire.

DRAWING CR-90

OBSTRUCTION AND BUMPER PROTECTION CLEARANCE REQUIREMENTS FOR PAD-MOUNTED EQUIPMENT

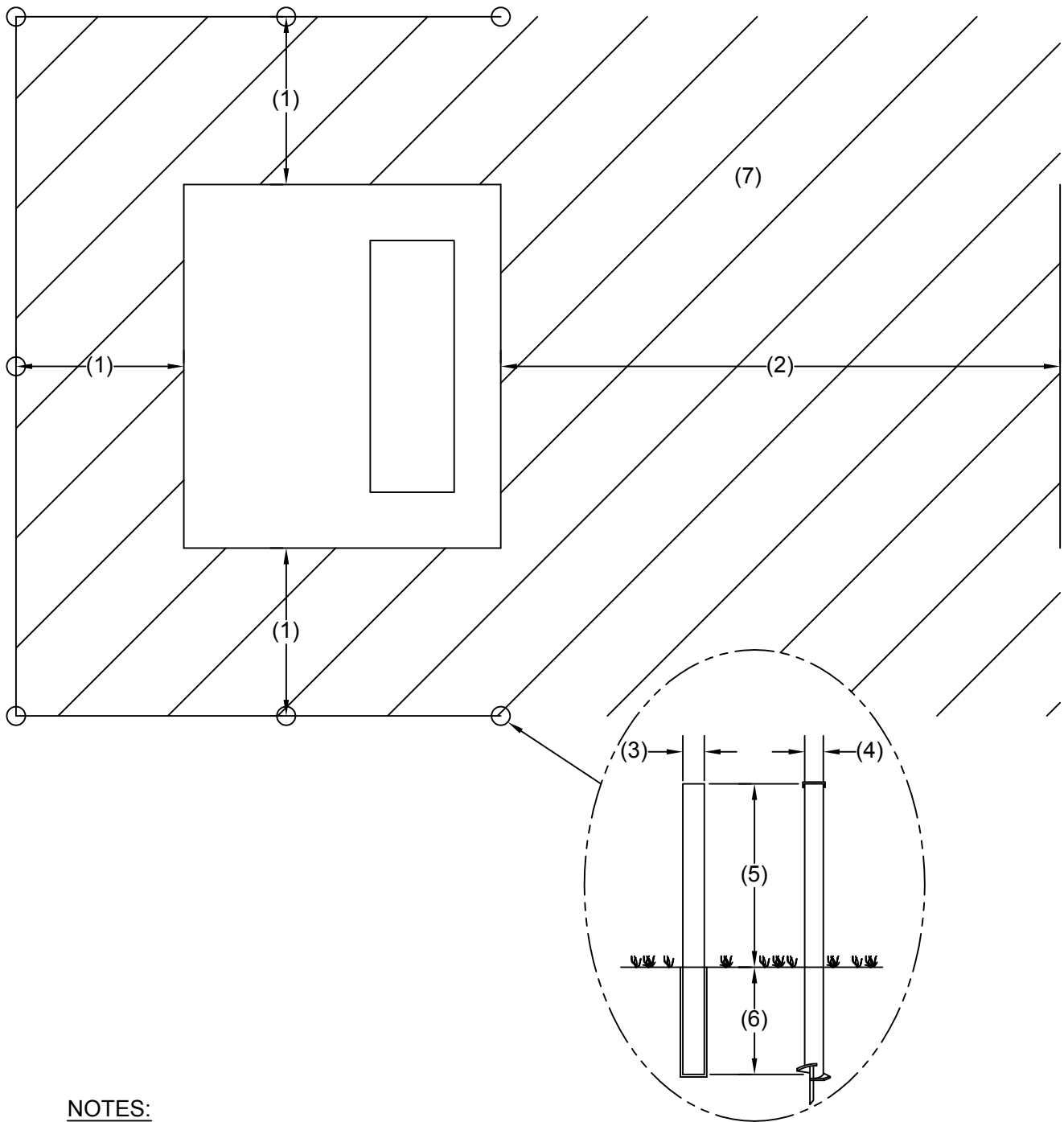

NOTES:

- (1) 3' minimum, non door-side for oil-filled equipment
2' minimum, non door-side for switch equipment
- (2) 10' minimum, door-side for pad-mounted equipment except primary metering
- (3) 4" diameter (slugged)
- (4) 3-1/2" diameter with helix
- (5) 4' minimum height
- (6) 3' minimum depth
- (7) The shaded area shown above must be level and free from obstructions.

DRAWING CR-100

PRIMARY METERING CABINET CLEARANCE REQUIREMENTS 200 AND 600 AMP

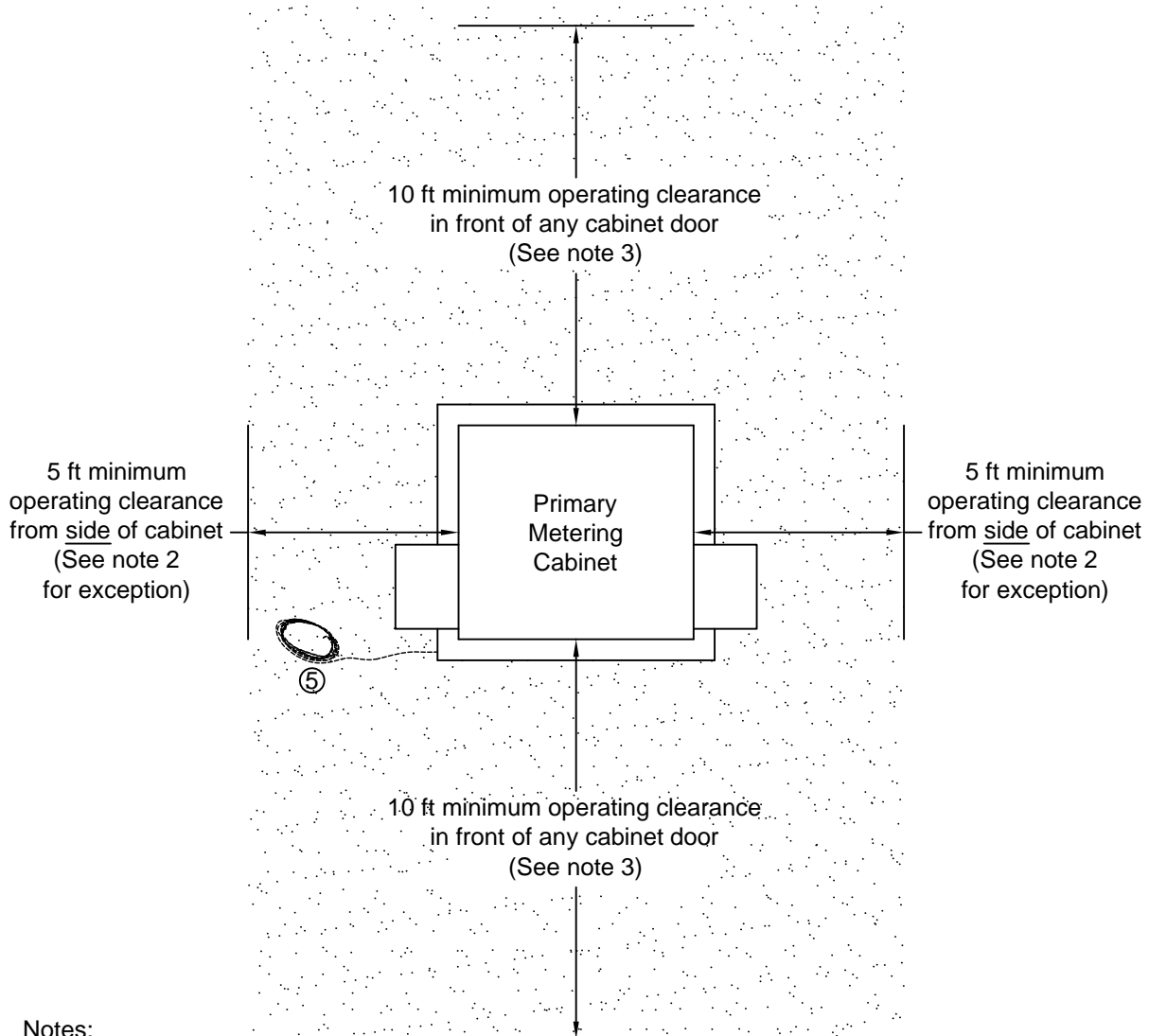

Notes:

1. These clearance requirements are for all switchgear including 600 A switchgear, padmount capacitor banks, padmount primary metering cabinets and 200 A load break centers (LBC's).
2. The 5 ft side clearance is access for cabinet replacement or access to low voltage enclosures and switch operators. This may be reduced to 3 ft for 200 A non-fused LBC's.
3. The 10 ft operating clearance is for switching and maintenance on the door sides of all cabinets.
4. Local Design/Construction management or Area Engineering shall be consulted for clearance issues, traffic set back, and sight triangle requirements from local regulatory agencies. The shaded area shown above must be level and free from obstructions.
5. In areas where other utilities will be installing above ground metal equipment within 6 ft of switchgear, the NESC requires the equipment to be grounded and the grounds bonded. Install 8 ft of #4 Cu bonding wire 3 ft to the side, 6 in back from the front of the pad and buried 12 in deep. Connect the coil to the ground rod lug, not the switchgear.
6. A minimum clearance of 4 ft is required from any fire hydrant (NESC 380D).
7. Design consideration should be given to the orientation of the doors with regard to traffic and hot stick operation. It may be best to orient the doors parallel to traffic.
8. Switchgear and their associated ground rods should be located 10 ft or more from fuel pipelines or high pressure gas lines. For facilities closer than 10 ft, notify the cathodic protection group for evaluation. (NESC095B2).

DRAWING CR-110

SETTING DEPTHS FOR CUSTOMER OWNED POLE

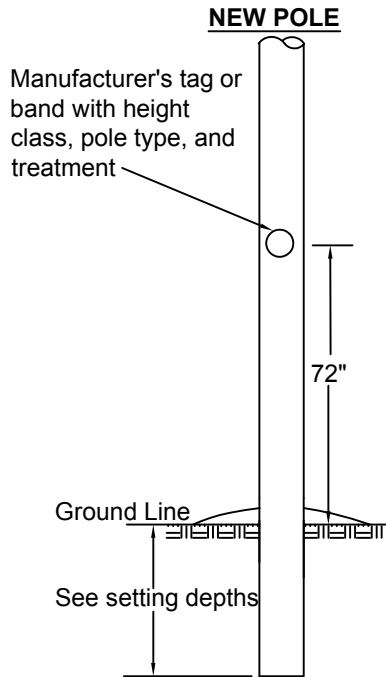

STANDARD POLE

NOTES:

1. Tamp firmly and mound dirt around pole, so when settled, water runs away from pole.
2. In poor soils use special backfill or set 1 foot deeper than standard to keep pole from leaning.

POLE SETTING DEPTHS

Length of Poles	25'	30'	35'	40'
Depth of Setting in Firm Soil (Standard Depth)	5'-6"	5'-6"	6'-0"	6'-0"

HILLSIDE POLE SET

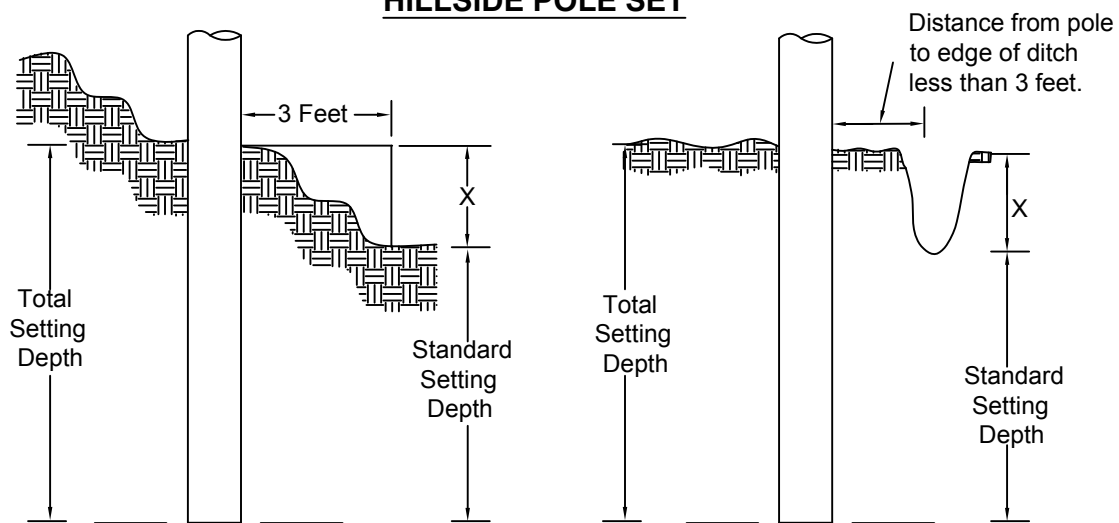

Total Setting Depth = Standard Setting Depth + X

NOTES:

1. Settling depth on slopes or by ditches equals the standard setting depth plus the distance between the groundline and the lowest ground within 3 feet of the pole.
2. Poles will lean if extra setting depth is not used.

DRAWING CR-120

CLEARANCE REQUIREMENTS FOR ELECTRIC METERS

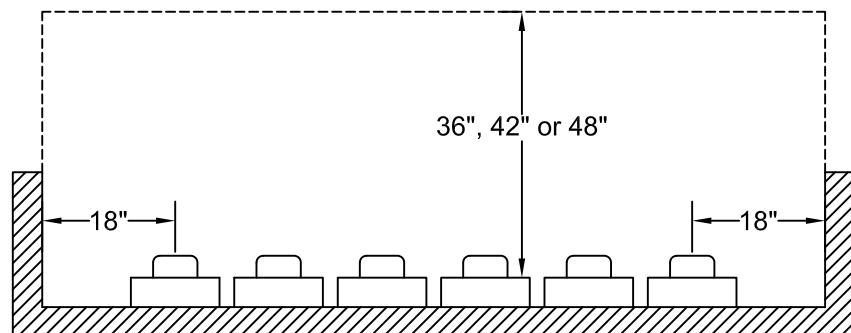
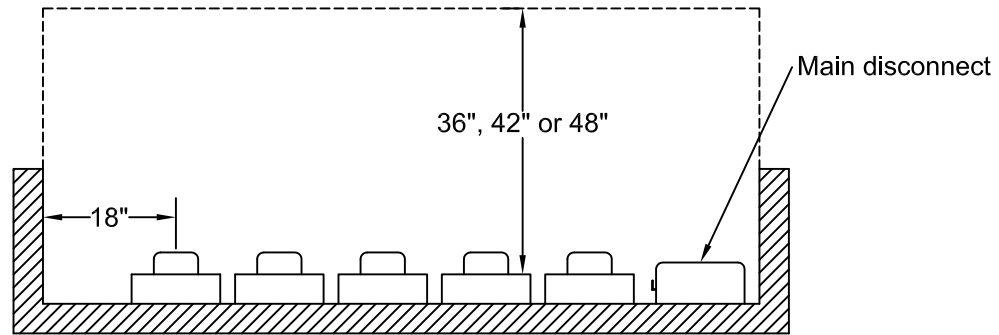
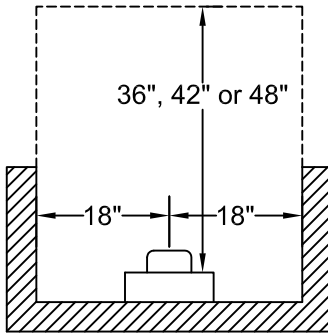

NOTES:

1. Area within dashed lines shall be clear of all obstructions.
2. 18" clearance shall be maintained to either side of the center line of the meter socket per NEC®.
3. 36", 42" or 48" clearance shall be maintained in front of meter socket per NEC®.
4. Height of working clearance shall be per NEC®.

DRAWING CR-130

COMPANY OWNED SERVICES CLEARANCE FROM SWIMMING POOLS

At 212° F Conductor Temperature				
Type of Structure Under or Next to Wire	Neutrals, Guys, Messengers; Surge protection Wires and Communications	Duplex, Triplex, Quadruplex, Lashed 0 - 750 V	Open Supply Conductors 0 - 750 V	Primary Conductors 750 V - 22 kV
Clearance In Any Direction To: Edge of pool, water surface, Base of diving platform or anchored raft. (Dimension A)	22'-0" (Note 1)	22'-6" (Note 1)	23'-0"	25'-0"
	18'-0" (WI)	18'-0" Multiplex (WI)	25'-0" Open Wire (WI)	27'-0" (WI)
Clearance In Any Direction To: Diving platform or Tower (Dimension B)	14'-0" (Note 6)	14'-6" (Note 6)	15'-0" (Note 6)	17'-0" (Note 6)
	16'-0" (WI)	16'-0" (WI)	16'-0" (WI)	18'-0" (WI)
Hot Tubs and Whirlpool Spas - Vertical (Notes 4 and 5)	10'-6"	11'-0"	11'-6"	13'-6"
Hot Tubs and Whirlpool Spas - Horizontal (Notes 4 and 5)	4'-6"	5'-0"	5'-6"	7'-6"

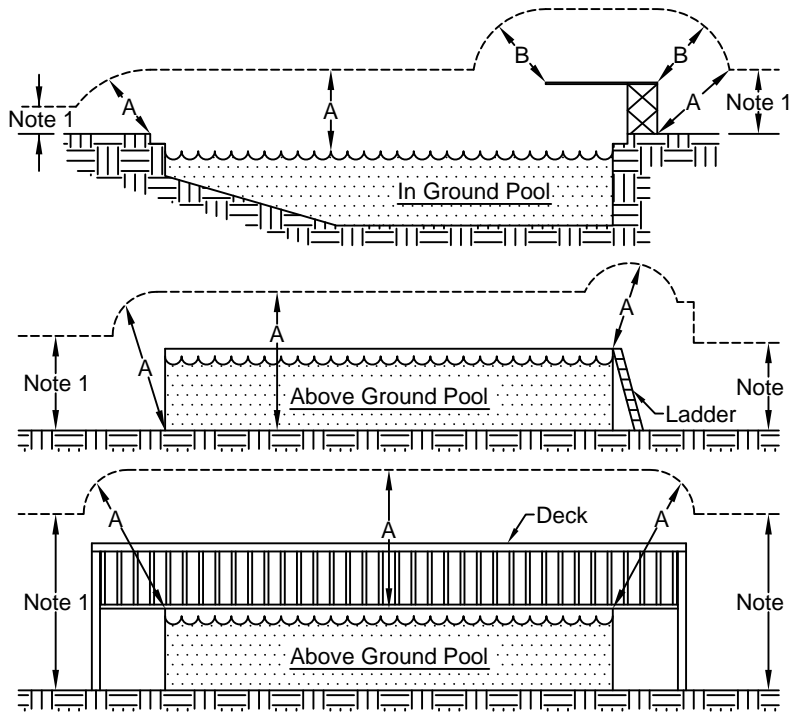

Clearances of Underground Secondary Service Lateral to Patios and Pools

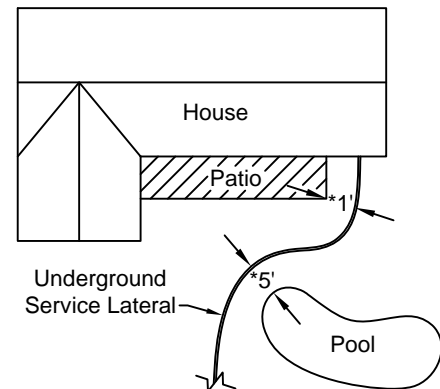

*These dimensions are minimum unless cable is in conduit. [NESC 351C](#)

Notes:

- 0-750 volts except open wire HORIZONTALLY greater than 10 feet from the edge of the pool or diving platform NEED ONLY a vertical clearance of 12.5 feet in pedestrian only traffic areas.
- The above table is for both above and below grade pools.
- Values from [NESC Table 234-3, Figure 234-3](#).
- For hot tubs and whirlpool spas, vertical and horizontal clearance is the same as clearance from balconies, decks and areas accessible to pedestrians. Clearance would be from the highest point a person could stand to the conductor (see Drawing [CR-70](#)).
- For hot tubs and whirlpool spas clearance is less than swimming pools since long handled cleaning equipment and rescue poles are not used.
- For horizontal clearance add 2 feet for conductor swing.
- Clearance of pools with decks is from the highest point upon which a person can stand.